

YAMAHA AV-55

Natural Sound Stereo Amplifier

8 Audio Inputs, 3 Video Inputs

Surround Sound Processor

Audio and Video Rec Out Selector

Total System Remote Control

Programmable Remote Control Transmitter

Thank you for purchasing the YAMAHA AV-55 stereo amplifier.

CENTER

CONTENTS

SAFETY INSTRUCTIONS	1
CAUTION: READ THIS BEFORE OPERATING YOUR AV-55	2
SUPPLIED ACCESSORIES	3
CONTROLS AND THEIR FUNCTIONS	4
USING THE REMOTE CONTROL TRANSMITTER	11
CONNECTIONS	13
OPERATIONS	16
HOW TO USE THE LEARNING FUNCTION	20
SPECIFICATIONS	23
TROUBLESHOOTING	25

OWNER'S MANUAL



IMPORTANT

Please check your unit's rear panel serial number and record it in the space below.

Model: **AV-55**

Serial No.:

Keep this owner's manual in a safe place for future reference.

SAFETY INSTRUCTIONS

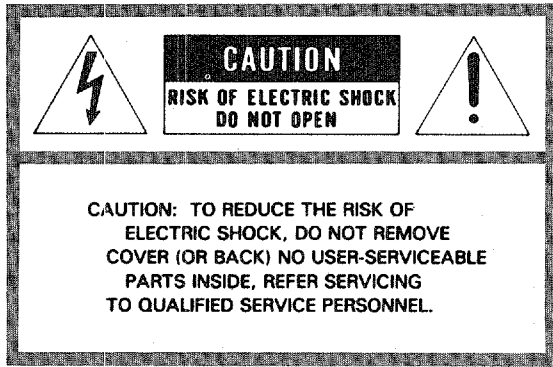

• Explanation of Graphical Symbols



The lightning flash with arrowhead symbol, within an equilateral triangle, is intended to alert you to the presence of uninsulated "dangerous voltage" within the product's enclosure that may be of sufficient magnitude to constitute a risk of electric shock to persons.

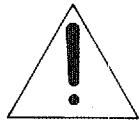

The exclamation point within an equilateral triangle is intended to alert you to the presence of important operating and maintenance (servicing) instructions in the literature accompanying the appliance.

WARNING
TO REDUCE THE RISK OF FIRE OR ELECTRIC SHOCK, DO NOT EXPOSE THIS APPLIANCE TO RAIN OR MOISTURE.

- 1 Read Instructions** — All the safety and operating instructions should be read before the appliance is operated.
- 2 Retain Instructions** — The safety and operating instructions should be retained for future reference.
- 3 Heed Warnings** — All warnings on the appliance and in the operating instructions should be adhered to.
- 4 Follow Instructions** — All operating and other instructions should be followed.
- 5 Water and Moisture** — The appliance should not be used near water — for example, near a bathtub, washbowl, kitchen sink, laundry tub, in a wet basement, or near a swimming pool, etc.
- 6 Carts and Stands** — This appliance should be used only with a cart or stand that is recommended by the manufacturer.
- 6A An appliance and cart combination should be moved with care.** Quick stops, excessive force, and uneven surfaces may cause the appliance and cart combination to overturn.
- 7 Wall or Ceiling Mounting** — The appliance should be mounted to a wall or ceiling only as recommended by the manufacturer.



- 8 Ventilation** — The appliance should be situated so that its location or position does not interfere with its proper ventilation. For example, the appliance should not be situated on a bed, sofa, rug, or similar surface, that may block the ventilation openings; or cabinet that may impede the flow of air through the ventilation openings.
- 9 Heat** — The appliance should be situated away from heat sources such as radiators, stoves, or other appliances that produce heat.
- 10 Power Sources** — The appliance should be connected to a power supply only of the type described in operating instructions or as marked on the appliance.
- 11 Power-Cord Protection** — Power-supply cords should be routed so that they are not likely to be walked on or pinched by items placed upon or against them, paying particular attention to cords at plugs, convenience receptacles, and the point where they exit from the appliance.
- 12 Cleaning** — The appliance should be cleaned only as recommended by the manufacturer.
- 13 Nonuse Periods** — The power cord of the appliance should be unplugged from the outlet when left unused for a long period of time.
- 14 Object and Liquid Entry** — Care should be taken so that objects do not fall into and liquids are not spilled into the inside of the appliance.

**CAUTION: READ THIS BEFORE
OPERATING YOUR AMPLIFIER**

15 Damage Requiring Service — The appliance should be serviced by qualified service personnel when:

- A. The power-supply cord or the plug has been damaged; or
- B. Objects have fallen, or liquid has been spilled into the appliance; or
- C. The appliance has been exposed to rain; or
- D. The appliance does not appear to operate normally or exhibits a marked change in performance; or
- E. The appliance has been dropped, or the cabinet damaged.

16 Servicing — The user should not attempt to service the appliance beyond those means described in the operating instructions. All other servicing should be referred to qualified service personnel.

17 Power Lines — An outdoor antenna should be located away from power lines.

18 Grounding or Polarization — The precautions that should be taken so that the grounding or polarization of an appliance is not defeated.

1. To ensure the finest performance, please read this manual carefully. Keep it in a safe place for future reference.

2. Install your unit in a cool, dry, clean place—away from windows, heat sources, and too much vibration, dust, moisture or cold. Avoid sources of hum (transformers, motors). To prevent fire or electrical shock, do not expose to rain and water.

3. Do not operate the amplifier upside-down. It may overheat, possibly causing damage.

4. Never open the cabinet. If a foreign object drops into the set, contact your dealer.

5. Do not place records or other objects on top of the amplifier; this will block the ventilation holes, cause the internal temperature to rise and may result in a failure.

6. Do not use force on switches, knobs or cords. When moving the set, first turn the unit off. Then gently disconnect the power plug and the cords connecting to other equipment. Never pull the cord itself.

7. Do not attempt to clean the unit with chemical solvents; this might damage the finish. Use a clean, dry cloth.

8. Be sure to read the “troubleshooting” section on common operating errors before concluding that your unit is faulty.

9. Do not connect audio equipment to the AC outlets on the rear panel if that equipment requires more power than the outlets are rated to provide.

10. If your unit has a voltage selector (General model only), check that it is set to your local voltage before you plug it in. If not properly set, reset the switch to indicate your supply voltage.

SUPPLIED ACCESSORIES

After unpacking, check that the following parts are contained.

• Remote control transmitter

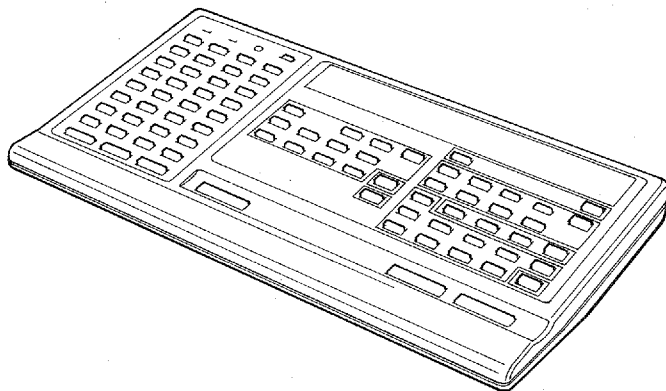

• Batteries (size "AA", R06)

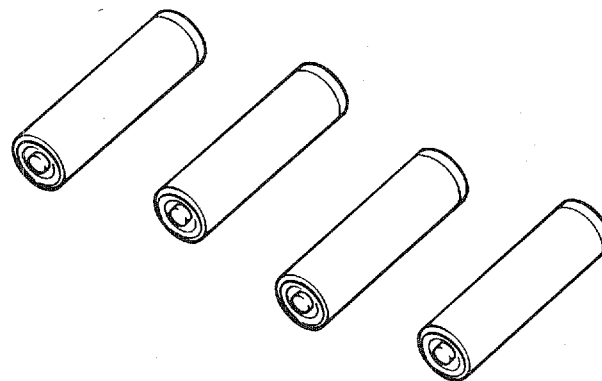

CONTROLS AND THEIR FUNCTIONS

FRONT PANEL

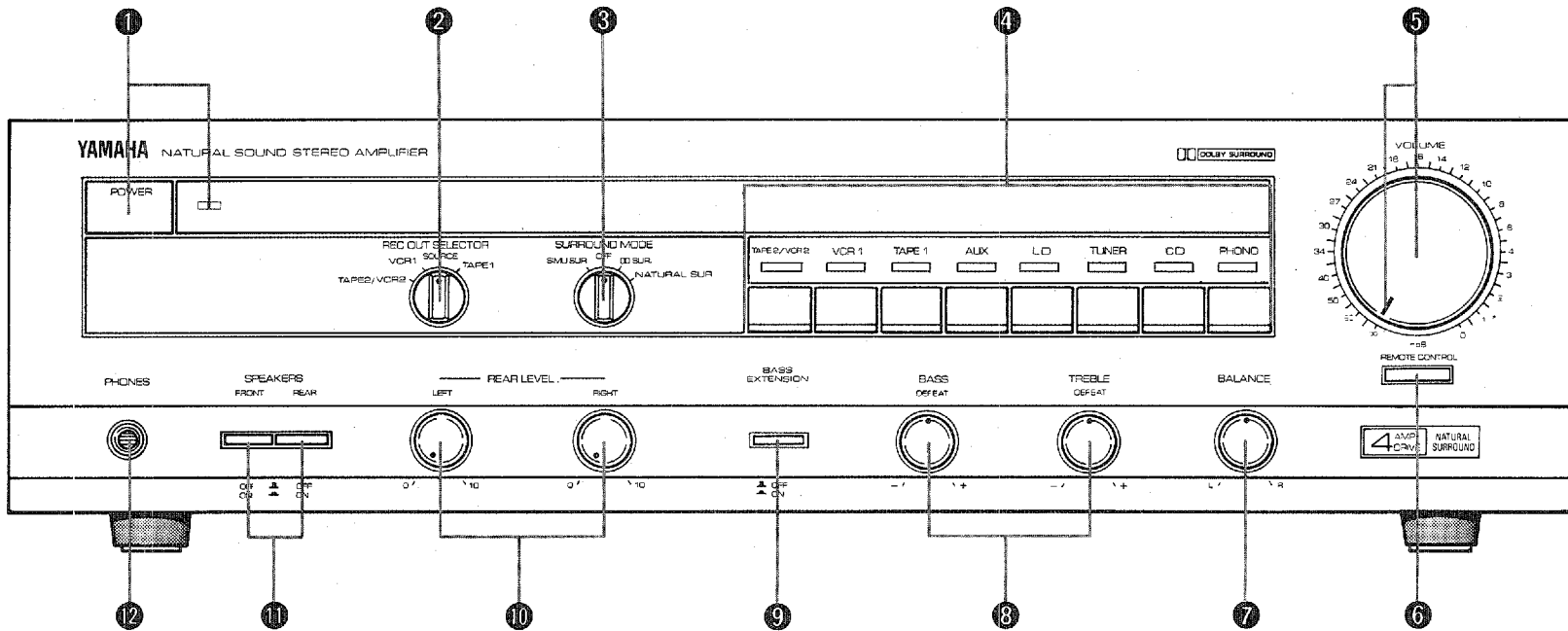

❶ **POWER switch and indicator**

Press this switch to turn the power on. Press the switch again to turn the power off.

❷ **REC OUT SELECTOR**

Used to select the program source to be recorded.

❸ **SURROUND MODE selector**

Used to select the surround mode according to the source played.

SIMU. SUR.

Natural surround effects can be given to monaural sources. While the front speakers reproduce ordinary monaural sound, the rear speakers reproduce the slightly sound which has been distributed to the left and right speakers by the comb filter.

OFF

Set to this position when listening to the normal 2- channel stereo sound without reverberation effect. The rear speaker signals are not output.

□□ SUR.

Set to this position when playing the program source having a "□□ DOLBY SURROUND" marking.

□□ DOLBY SURROUND

* Manufactured under license from Dolby Laboratories Licensing Corporation. Additionally license under one or more of the following patents: U.S. numbers 3,632,886, 3,746,792 and 3,959,590; Canadian numbers 1,004,603 and 1,037,887. "Dolby" and the Double-D symbol are trademarks of Dolby Laboratories Licensing Corporation.

NATURAL SUR.

Natural surround effects can be reproduced from ordinary stereo sources, using, YAMAHA's original surround processor circuit.

* No sound is output from the rear speakers when the played source is monaural.

❹ **input selectors and indicators**

Used to select the audio or video source to be heard or watched. When either the audio or video source is selected with input selector, the indicator above the selector lights in red. For video sources, the

indicator turns green when other audio source is selected. At this time, the audio source will not be heard.

❺ **VOLUME control and indicator**

This control is used to raise or lower the output volume level. It acts as a master volume control, increasing or decreasing the signal level to both front and rear speaker pairs. The built-in indicator lights when the POWER switch is set to ON.

❻ **REMOTE CONTROL sensor**

This is used to receive signals from the remote control transmitter.

❼ **BALANCE control**

Use this control to concurrently change the left and right output volume to the speaker terminals.

❽ **TONE controls**

BASS

Used to increase or decrease the low frequency response. The DEFEAT position produces flat response.

TREBLE

Used to increase or decrease the high frequency response. The DEFEAT position produces flat response.

❾ **BASS EXTENSION switch**

Used to activate a circuit which effectively extends the low frequency output of the amplifier.

❿ **REAR LEVEL controls**

These controls raise or lower the volume at REAR SPEAKERS terminals.

⓫ **FRONT/REAR SPEAKERS switches**

Set these switches to select the speakers to be driven. If sound from the speakers is not desired (when using headphones, for example) set these switches to OFF.)

⓬ **PHONES jack**

Insert the headphone plug into this jack for private listening.

■ REAR PANEL

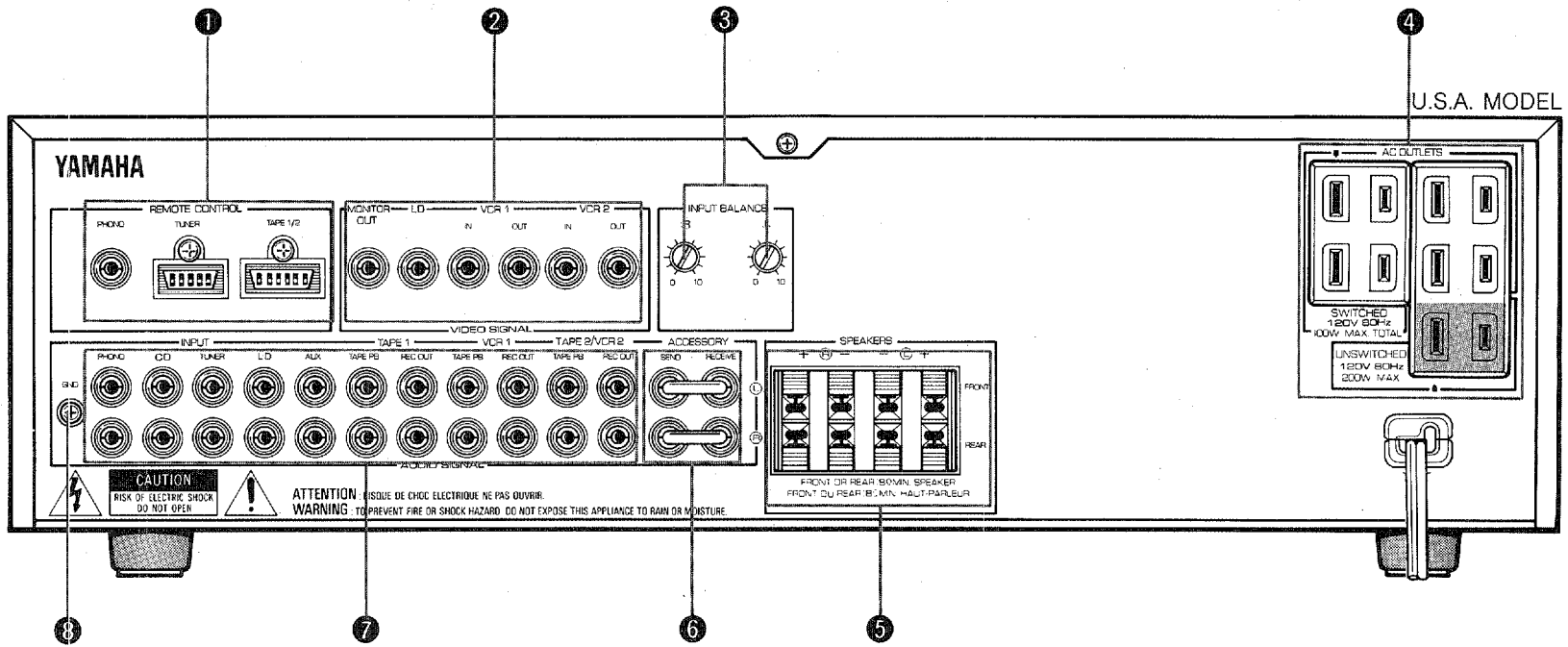

❶ REMOTE CONTROL connectors

Use these to connect compatible YAMAHA components (turntable P-31, tuner T-33, cassette deck K-40 or K-45) to your amplifier for remote control of each component.

PHONO

Connect to a turntable using the cable with a mini-plug connectors.

TUNER

Connect to a tuner using the cable with a 5-pin connector.

TAPE

Connect to a cassette deck using the cable with 6-pin connector.

❷ Video signal jacks

Use these to connect the video signal cords from your components to the amplifier. They should be connected to the proper input/output jacks for each unit.

MONITOR OUT

Connect this to the video in jack on a video monitor.

LD

Connect a Laser Vision Disc player.

VCR 1

Connect a first HiFi video cassette recorder.

VCR 2

Connect a second HiFi video cassette recorder.

❸ INPUT BALANCE controls

Use this control to obtain the best surround condition.

For details on the surround condition adjustment, refer to page 19.

❹ AC OUTLETS

Use these to connect the power cords from your components to the amplifier.

The power to the SWITCHED outlets is controlled by the amplifier's POWER switch. They will supply power to any component whenever this unit is turned on by the front panel POWER switch.

The power to the UNSWITCHED AC OUTLET (1 pc., the shaded part in the figure on page 6) is not controlled by the amplifier. It will continually supply power to any unit connected.

The maximum power (total power consumption of components) that can be connected to the SWITCHED AC OUTLETS is 100 watts and to the UNSWITCHED AC OUTLETS is 200 watts.

Note that the AC outlets are size-coded for polarity, so insert plugs correctly.

❺ FRONT and REAR SPEAKERS terminals

Connect front and rear speakers to these terminals. See the Connections section of this manual for details on speaker connections.

❻ ACCESSORY jacks

Use these jacks to connect an optional graphic equalizer, sound processor, etc. For normal operation, keep the pins connected.

⑦ Audio signal connection jacks

Use these to connect the audio signal cords from your components to the amplifier. They should be connected to the proper input/output jacks for each unit. Be sure that L and R channels are connected correctly.

TAPE 2/VCR 2

Connect a second cassette deck or audio signal of a HiFi video cassette recorder for both recording and playback.

VCR 1

Connect a HiFi video cassette recorder for both recording and playback.

TAPE 1

Connect a first cassette deck for both recording and playback.

AUX

Connect another audio component. A turntable cannot be connected to these jacks.

LD

Connect the audio signal of an LD player.

TUNER

Connect a tuner.

CD

Connect a compact disc player.

PHONO

Connect a turntable.

⑧ GND terminal

Connect the ground wire of a turntable (except P-31).

■ REMOTE CONTROL TRANSMITTER

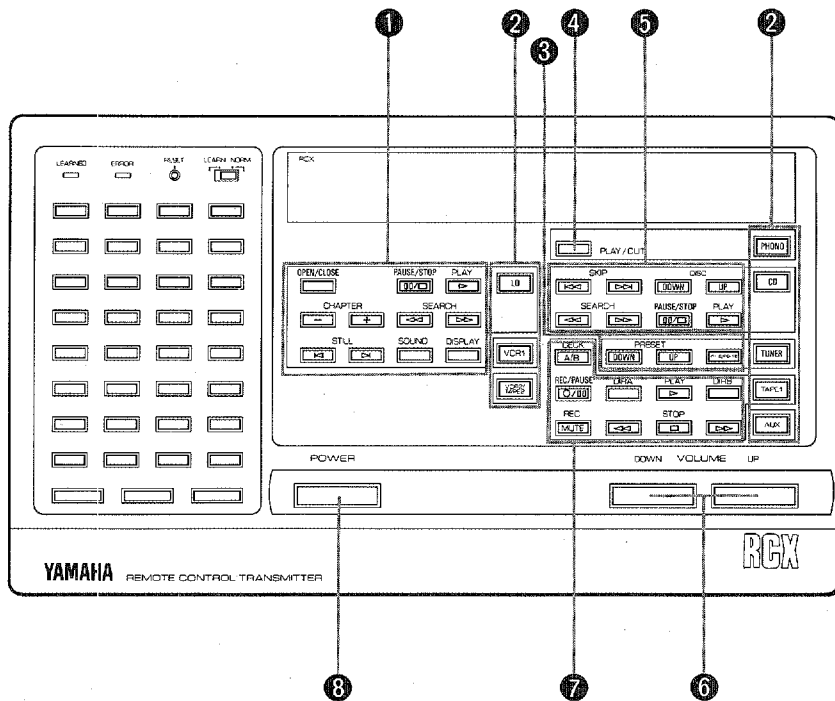

① LD player section

These keys are used to operate the YAMAHA LD player.

OPEN/CLOSE

Press this key to open/close the disc tray.

PAUSE/STOP

Press this key once to temporarily stop the player operation. When it is pressed again, the player enters stop mode.

PLAY

Press this key to start play. If this key is pressed when the disc tray is opened, the disc tray will close and the unit will enter play mode. When this key is pressed during other modes (pause, still, etc.), that mode is released and play is resumed.

CHAPTER

Press the - key to detect the beginning of the current chapter. If it is kept pressed, the chapter number is reversed continuously.

Press the + key to detect the beginning of the next chapter. If it is kept pressed, the chapter number is advanced continuously.

SEARCH

When the <<< key is pressed during play, play is reversed at high speed. When the >>> key is pressed during play, play is advanced at high speed.

STILL

When one of these keys is pressed during LD (CAV) disc play, the picture freezes. Every time the <<< key is pressed again, the picture reverses frame-by-frame.

Every time the >>> key is pressed again, the picture advances frame-by-frame.

SOUND

Every time this key is pressed, the audio signal changes in the order: STEREO → 1/L-CH → 2/R-CH → STEREO.

DISPLAY

When this key is pressed during play, the monitor screen shows the following data.

With LD (CAV) discs:

Chapter and frame numbers

With LD (CLV) discs:

Chapter and time

With CD discs or the audio section of CDV discs:

Total time, remain time or track time

With the video section of CDV discs:

Track/index numbers and track time

② Input selector keys

Select the desired program source with these keys (CD, PHONO, TAPE 2/VCR 2, VCR 1, TAPE 1, LD, AUX or TUNER).

③ Tuner section

These keys are used to select the broadcast station presets on the tuner (T-33) connected to this unit.

UP

Press to select the broadcast station preset on the tuner. Each time this key is pressed, the preset number is increased by one. (Ex: P7 → P8)

When the key is pressed while the P8 (P16) station is received, the preset number will be changed to P1 (P9).

DOWN

Press to select the broadcast station preset on the tuner. Each time this key is pressed, the preset number is decreased by one. (Ex: P8 → P7)

When the key is pressed while the P1 (P9) station is received, the preset number will be changed to P8 (P16).

P1-8/P9-16

Each time this key is pressed, the preset station range is changed between P1-8 and P9-16 alternately.

④ Turntable section

This key is used to start and stop record play on the turntable (P-31) connected to this unit. This key functions same as the PLAY/CUT key on the turntable. Pressing this key starts record play and pressing it again stops play.

⑤ CD player section

The compatible YAMAHA CD player (CDC-50 or bearing the RS mark) can be controlled directly with the remote control transmitter.

DISC UP/DOWN

When a CD player which has an Auto charger mechanism is used, press these keys to select the disc No. to be played.

PAUSE/STOP

Used to set the player to pause or stop mode. Pressing the key once pauses temporarily and pressing it again stops play.

PLAY

Press this key to start play.



Press to advance to the beginning of the next tune.



Press to return to the beginning of the current tune. When this key is pressed at the beginning of the tune, play will start at the beginning of the previous tune.



Press to audibly fast forward the tune.



Press to audibly fast rewind the tune.

⑥ VOLUME control keys

These keys are used to adjust the volume level heard from the speakers connected to this unit.

USING THE REMOTE CONTROL TRANSMITTER

⑦ Tape deck section

These keys are used to operate the cassette deck (K-40 or K-45) connected to this unit.

A/B

Press to select the deck to be operated between the deck A and B on the double cassette deck.

DIR A

Press to change the tape running direction of the deck A on the double cassette deck.

PLAY

Press to start tape play. When the double cassette deck is used, pressing the key starts tape play on the last playing deck.

DIR B

Press to change the tape running direction of the deck B on the double cassette deck.

REC/PAUSE

Press to start recording.

REC MUTE

Press to make a non-recorded section during recording.



Press to fast forward the tape.

STOP

Press to stop the tape.



Press to rewind the tape.

⑧ POWER key

Press this key to turn the amplifier ON and OFF.

This remote control transmitter has a learning function.

For details, refer to the "HOW TO USE THE LEARNING FUNCTION" section described later.

The remote control transmitter supplied with your amplifier is designed to control all the most commonly used features of the amplifier. If the CD player, tuner, turntable and cassette deck connected to your amplifier are YAMAHA components designed for remote control compatibility, then this remote control transmitter will also control various functions of each component. Please consult your YAMAHA dealer for information on which components are compatible with the remote control transmitter. Note that this Remote Control will directly operate any compatible YAMAHA CD player (CDC-50 or CD player with RS mark).

■ BATTERY INSTALLATION

The remote control unit uses 4 batteries (size "AA", R06). Install them according to the following illustration. Be sure that they are installed correctly.

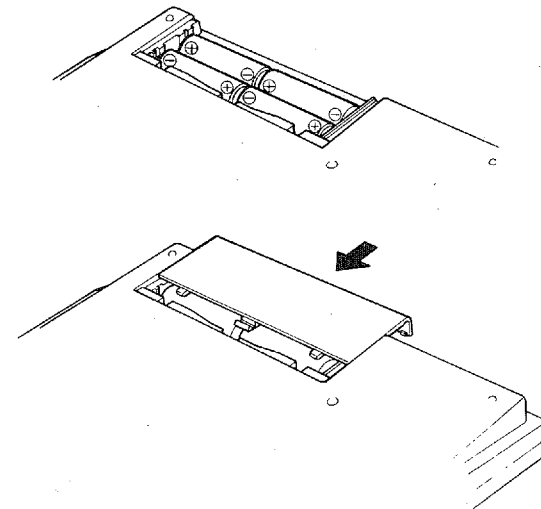

■ BATTERY REPLACEMENT

When the remote controllable distance becomes short, batteries are exhausted. Replace two batteries with new ones.

Battery cautions

Incorrect use of the battery may cause leakage or explosion. Be careful the following items:

When replacing:

- Place the batteries in correct (+) and (-) polarities as indicated in the battery compartment.
- Do not use an old battery together with a new one.
- Do not use different kinds of batteries (alkaline, heavyduty, manganese, Ni-Cad, etc.) at the same time.

Rechargeable batteries:

- There are two kinds of batteries in the market; rechargeable and non-rechargeable. Read the caution labels on the battery carefully.

Use with the remote control transmitter:

- When not in use for an extended period of time, remove the batteries from the remote control transmitter.
- Replace the exhausted batteries as soon as possible.

To prevent accident:

- Never disassemble, heat the battery, or throw into a fire. Dispose of the batteries in specified places.
- Do not connect (short) (+) and (-) directly with wire, piece of metal, etc.

In case of leakage:

Wipe off the electrolyte in the battery compartment completely before replacement with new batteries.

■ OPERATION RANGE

You must point the remote control unit toward the amplifier and be within about 7 meters (23 feet) of it for proper operation.

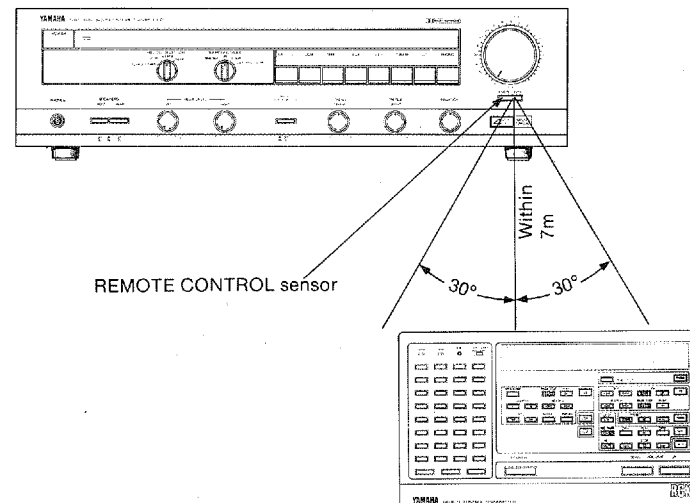

CONNECTIONS

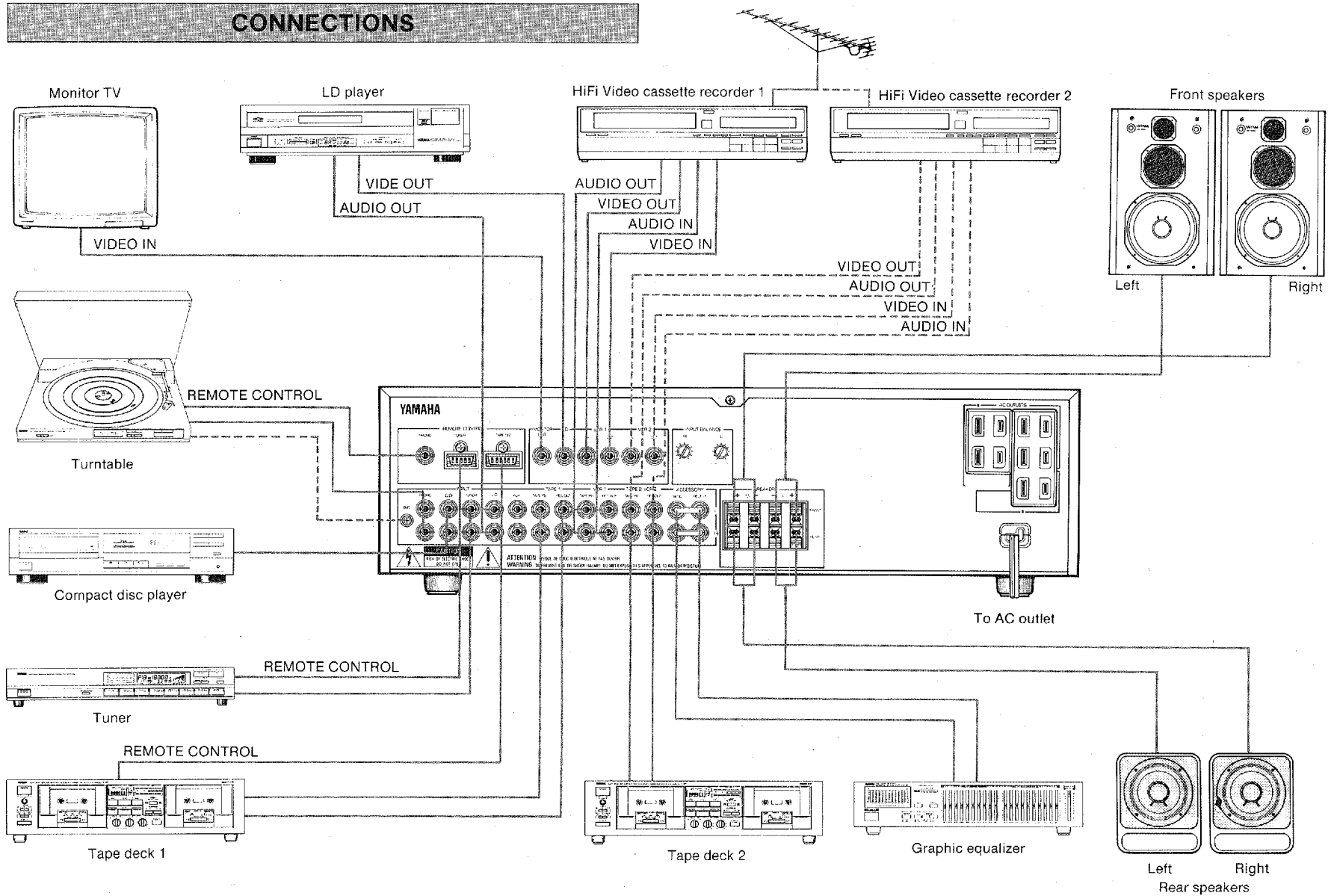

■ NOTES ON CONNECTIONS

- Be sure to turn off the power to all units before making any connections.
- The power cord and AC outlets have polarized configurations, one socket/blade wider than the other. The purpose of this is to match polarities. Observe the polarity when connecting the AC outlets of amplifier and other equipment.

■ TURNTABLE

Connect the output cords of the turntable to the PHONO jacks, and connect the ground cord to the GND terminal. This should produce minimum hum, but in some cases better results are obtained with this cord disconnected.

■ COMPACT DISC PLAYER

Connect the output jacks of the compact disc player to the CD jacks.

■ TUNER

Connect the output jacks of the tuner to the TUNER jacks.

■ LD PLAYER

Connect the video output jack from an LD player to the LD jack.
Connect the audio output jacks from an LD player to the LD jacks.

■ OTHER AUDIO COMPONENTS

Connect the output jacks of another audio source to the AUX jacks. (A turntable cannot be connected to the AUX jacks.)

■ TAPE DECK 1

Connect the cords from a cassette deck to the TAPE 1 jacks. The playback (LINE OUT) jacks of the cassette deck go to the TAPE PB jacks, and the record (LINE IN) jacks of the cassette deck go to the REC OUT jacks.

■ VCR 1

Connect the video jacks of a HiFi video cassette recorder to the VCR 1 jacks. The playback (VIDEO OUT) jack of the VCR goes to the TAPE PB jack, and the record (VIDEO IN) jack goes to the REC OUT jack. Connect the audio output jacks of a HiFi video cassette recorder to the VCR 1 jacks. The playback (AUDIO LINE OUT) jacks of the VCR go to the TAPE PB jacks, and the record (AUDIO LINE IN) jacks go to the REC OUT jacks.

■ TAPE DECK 2/VCR 2

Connect the audio jacks of a second cassette recorder or HiFi video cassette recorder to the TAPE 2/VCR 2 jacks in the same way. Connect the video jacks of a second HiFi video cassette recorder to the VCR 2 jacks in the same way.

■ MONITOR TV

Connect the video in jack of a monitor to the MONITOR OUT jack. Note that the audio connections to the monitor are not necessary as the audio portion of the signal is sent to the speakers connected to the amplifier.

■ OTHER COMPONENTS

To connect a graphic equalizer, sound processor, etc., remove the pins from the ACCESSORY jacks as shown below.

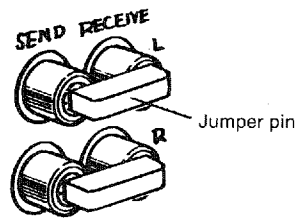

Connect the input jacks of the audio component to the SEND jacks and output jacks to the RECEIVE jacks with correct right and left channels.

■ REMOTE CONTROL CABLE

The REMOTE CONTROL connectors are used when you have YAMAHA compatible components.

These connections allow you to control the components from the supplied remote control transmitter.

Connect the remote control cables from the components to the correct connectors on your amplifier (i.e. PHONO, TUNER, TAPE).

Note that no cable is necessary for a compatible CD player (CD-50, CDC-50 or CD player with RS mark) as the remote control transmitter operates the player directly.

■ SPEAKERS

Connect the SPEAKERS terminals to your front and rear speakers with the proper gauge of wire cut to be as short as possible. Press the speaker wire terminal tabs down, then insert the bare wires and secure them by releasing the tabs. If these connections are faulty, no sound will be heard from the speakers. Make sure that the polarity of the speaker wires is correct. That is, observe the + and - markings. If these wires are reversed, the sound will be unnatural and will lack bass. Do not coil up excess speaker wire or bundle the speaker wires with the power cords.

■ POWER CORDS

Connect the power cord of your amplifier to an AC outlet.

OPERATIONS

■ TO PLAY PROGRAM SOURCE

1. Press the POWER switch.
2. Select the program source to be heard or watched with the input selector.
When either the audio or video source is selected with input selector, the indicator above the selector lights in red. For video sources, the indicator turns green when other audio source is selected.
3. Play the program source.
4. Adjust the VOLUME and tone controls.

For details of the surround mode, refer to "USING THE SURROUND PROCESSOR" on page 17.

■ TO RECORD AUDIO SOURCE

1. Press the POWER switch.
2. Select the program source to be recorded with the REC OUT SELECTOR.
3. Play the program source to be record and set the tape deck or HiFi video cassette recorder to record mode.

The settings of the SURROUND MODE selector, tone controls, VOLUME control and BASS EXTENSION switch do not affect the recording.

4. To listen to another program source during recording, select the program source to be listened to with the input selector.

■ TO DUB AUDIO TAPES

1. Press the POWER switch.
2. Set the REC OUT SELECTOR to select the program source to be played recorded.
3. Set the tape decks or video cassette recorders to play and record modes respectively.

4. To listen to another program source during dubbing, select the program source to be listened to with the input selector. The settings of the SURROUND MODE selector, tone controls, VOLUME control and BASS EXTENSION switch do not affect the dubbing.

■ TO RECORD VIDEO SOURCES

1. Press the POWER switch.
2. Select the desired program source to be recorded with the REC OUT SELECTOR.

It is possible to record the video signal of a video source together with the audio signal of another component.

In this case, set the REC OUT SELECTOR to the SOURCE position and select the desired video and audio sources with the input selector.

* Be sure to first press the input selector for video source, then press the input selector for audio source.

3. Set the VCR for recording to the record-pause mode.
4. Play the video and audio sources to be recorded together and start recording with the recording VCR at the same time.



■ TO DUB VIDEO TAPES

1. Press the POWER switch.
2. Set the REC OUT SELECTOR to select the program source to be played.
3. Set the HiFi video cassette recorders to play and record modes respectively.
4. To listen to another program source during dubbing, select the program source to be listened to with the input selector. The settings of the SURROUND MODE selector, tone controls, VOLUME control and BASS EXTENSION switch do not affect the dubbing.

■ USING THE SURROUND PROCESSOR

This unit incorporates a sophisticated, multi-mode surround processing circuitry which allows you to expand the audio sound field for a theater-like experience in the listening/viewing room.

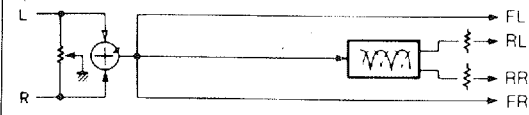
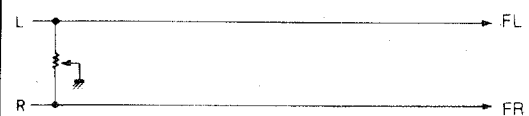
- The surround processor in this unit is effective only when the unit is used in a 4-speaker system setup.

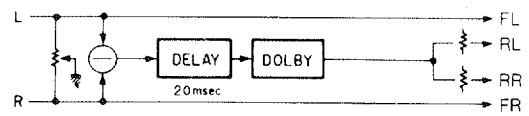
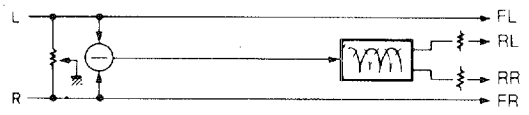
	Source	Position	Signal processing routes	Rear speaker output
Mono sources	Video/Sound Sports programs	SIMULATED SURROUND		A comb filter distributes each band to right and left. Very low sounds go to the left channel, and very high to the right (same output as from front speakers).
All sources		OFF		The rear speaker signals are not output.
Stereo sources	 DOLBY SURROUND™ For video programs with the Dolby	 SURROUND		Dolby surround decoder reverberation components are delayed, and output via the rear, left and right speakers.
	Video/Sound Sports programs	NATURAL SURROUND		Reverberation components are divided between the rear, left and right speakers by a comb filter. This results in a naturally expansive sound with a broad band.

When replaying mono sources in the  SURROUND or NATURAL SURROUND positions, no sound is heard from the rear speakers.

FL: Front left speaker output
FR: Front right speaker output
RL: Rear left speaker output
RR: Rear right speaker output

■ REAR SPEAKER PLACEMENT

The placement of a rear speaker pair in the listening room will greatly affect the overall sound field created. A small pair of speakers is all that is really required to create the full effect, and the most basic speaker placement configuration is the one shown in Fig. A. This setup is ideal for creating a theater-like atmosphere for movies and other video programs.

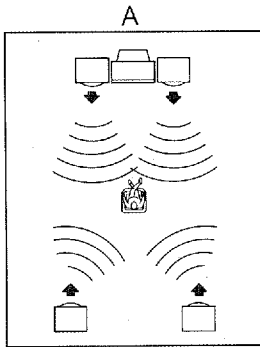

The "B" setup creates a sound field with added depth, much like that experienced in a live concert hall, where all the sound is coming at you from the front. It is most appropriate for musical sources, rather than video programs.

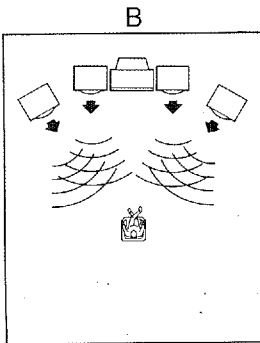

The "C" speaker placement configuration effectively "widens" the sound field, and is suitable for movies and other video programs.

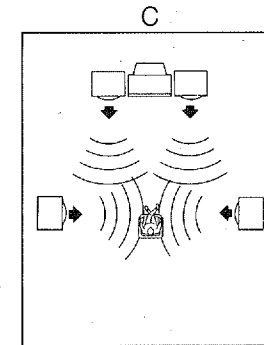

While the most basic speaker placement setup is recommended at first, by experimenting with different speaker placements for each musical or video source, and with each surround mode, you will be able to create a wide variety of sound field effects suited to your listening environment, and to your own particular tastes.

■ □□ (Dolby) SURROUND

With a great number of movies made today, the sound track is specially encoded with the Dolby surround mode for playback in movie theaters equipped with Dolby surround processing sound systems. This is responsible for the incredibly lifelike effect you experience at movie theaters: while dialogue comes at you from the front speakers, sound effects, background noise, and other ambient noise in the sound track comes at you from behind as well. You are literally surrounded in sound.

Dolby surround is encoded on the sound track of commercially available video cassettes and video discs as well. When you play tapes encoded with Dolby surround on your home video system, the Dolby surround mode on this unit decodes the signal and feeds the sound effects, background noise, ambient noise, etc. through your rear speakers in your living room.

The Dolby surround mode will have no effect on video sources not encoded with Dolby surround.

■ NATURAL SURROUND

The Natural Surround is an exclusive YAMAHA surround processing mode which is effective with all music and video sources. It creates a natural, lifelike surround effect without the use of delay circuitry, adding considerable depth and imaging to all audio sources. It is recommended for both music listening and for viewing stereo video sources.

NOTE

If a monaural sound source is used in the Natural Surround mode, no sound will be heard from the rear speakers.

■ SIMULATED SURROUND

The Simulated Surround mode is also intended for monaural audio sources, such as video and TV programs, it creates a surround sound effect, and employs a delay circuit for an extra dimension of depth and imaging.

■ OFF

When the selector is set to OFF, no surround processing is in effect.

■ INPUT BALANCE CONTROL ADJUSTMENT

To obtain the best surround condition, be sure to adjust the rear panel INPUT BALANCE control.

1. Set the front speaker selector to off or disconnect the speaker wires so that the sound from the front speakers will not be heard.
2. Set the front panel controls as follows.
SURROUND PROCESSING MODE button --- SUR.
REAR LEVEL volume control --- maximum
3. Play a monaural program source (such as an FM mono station).
4. Turn up the VOLUME control so that you can hear the monaural program source through the rear speakers.
5. Then minimize the rear speakers' output by slightly reducing one or the other INPUT BALANCE control until you achieve a "null" (i.e., minimum output from your rear speakers).
NOTE: As you approach the "null", turn up the VOLUME to better hear your rear speakers.

■ OPERATION

1. Play the program source.
2. Select the surround mode with the SURROUND MODE selector.
3. Adjust the REAR LEVEL controls.
4. Use the VOLUME control to adjust the whole sound level.

HOW TO USE THE LEARNING FUNCTION

The supplied remote control transmitter is a "learning" remote control unit that allows for centralized control of various Audio/Visual equipment, solving the complicated problem of operating several remote controllers for your system.

NOTES

- If the indicators are only dimly lit when pressing a key, the batteries are weak. Replace the batteries.
- All memorized functions will be retained while you replace the batteries. However, if no batteries are installed for an hour, the memory will be erased and will have to be programmed again.

CONTROLS AND FUNCTIONS

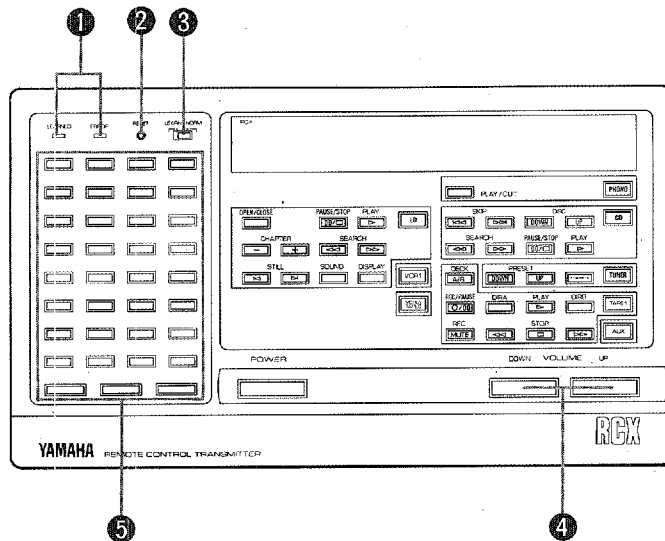

for camera and camera remote

1 LEARNED and ERROR indicators

These indicators show the operation mode of the remote control transmitter.

2 RESET button

Used to clear a programmed signal.

3 NORM/LEARN switch

This switch is used to select between LEARN (program) and NORM (control) modes.

4 Preset/learning keys

These keys have already been preset with signals for controlling YAMAHA audio equipment (with the RS mark).

However, if desired, other signals can be "learned" by these keys (over the preset signals), in the same way as for the ordinary learning keys.

5 Learning keys

These keys can be used to "learn" (program) signals from another remote controller.

OPERATIONS

To program the signals of another remote controller in this remote control transmitter (RCX), please follow the steps below.

1. Switch the NORM/LEARN switch to the LEARN position.

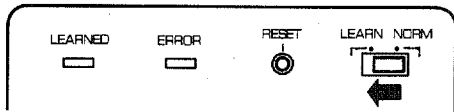

2. Position the RCX and the remote control unit to be memorized head to head.

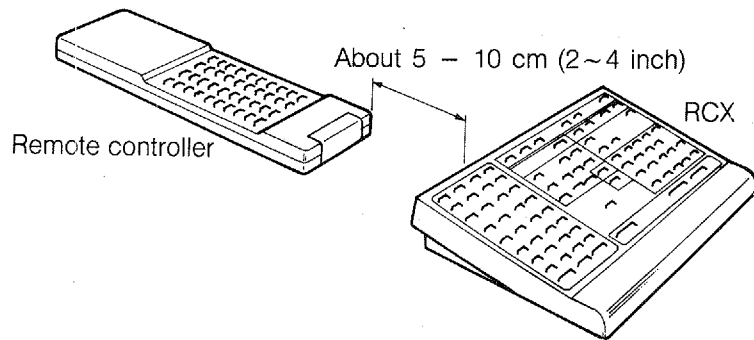

3. Select and press the learning or preset/learning key on the RCX to be programmed.

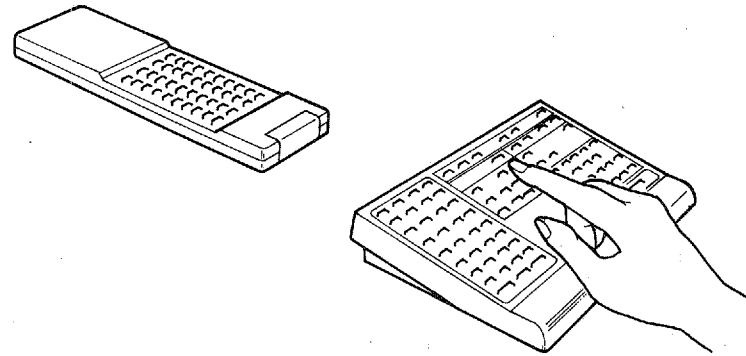

The LEARNED indicator will flash for about 15 seconds. If the ERROR indicator lights up when the key is pressed, a signal has already been programmed in that key. If the programmed signal can be replaced, proceed to the next step.

If the programmed signal cannot be replaced, press another learning or preset/learning key on the RCX.

4. While the LEARNED indicator is flashing, press a key on the other remote controller.

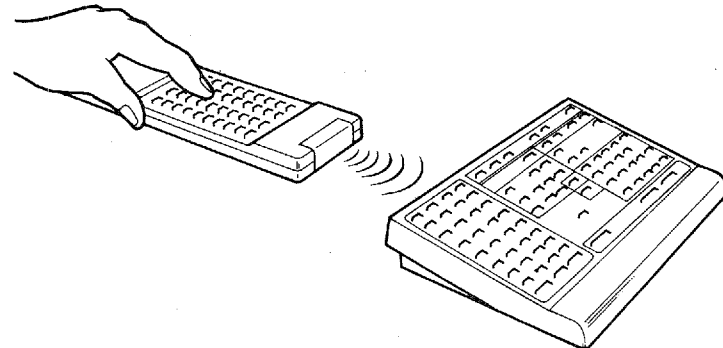

The LEARNED and ERROR indicators will light steadily while receiving the signal. Press the other remote controller's key until these indicators turn off.

The LEARNED indicator will light for about 2 seconds when the memorization of a function is successfully completed.

The ERROR indicator will light for about 2 seconds when the memorization of a function is unsuccessful. In this case, please try again.

5. Repeat steps 3 and 4 until all programming is complete.
6. Once programming is complete, set the NORM-LEARN switch to the NORM position.

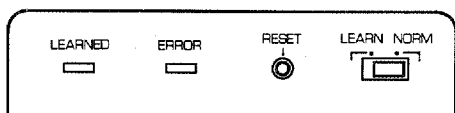

7. Use the supplied seals to indicate the functions for which the learning and preset/learning keys have been programmed.

It is recommended that you first determine the best and most convenient layout of the keys for the various functions you plan to program and attach the seals accordingly, then program the keys correspondingly.

If programming is not carried out successfully, or if the remote control operation is not successful although programming was successful, check the following:

- Are the batteries of the other remote controller is weak?
In this case, even when the other remote controller can operate the unit, its signal strength is too weak for the RCX. Replace the batteries of the other remote controller.
- Is the distance to the other remote controller too small or too large, or are they not in line?

- Is a strong light, such as direct sunlight, incident on the RCX?

If the signal to be stored is too long.

When the signal to be stored is too long, the RCX automatically enlarges the work area capacity and stands by for a second entry. Please try the storage operation again.

TO ERASE A PROGRAMMED SIGNAL

To erase a signal programmed on a learning key or a preset/learning key, proceed as follows.

1. Set the LEARN/NORM switch to the LEARN position.
2. Press the RESET button.

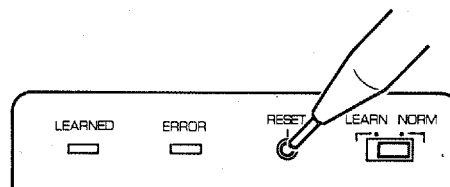

The LEARNED and ERROR indicators will flash for about 15 seconds.

3. While the LEARNED and ERROR indicators are flashing, press the learning or preset/learning key for which you want the programmed signal to be erased.

The ERROR indicator will turn off, and then the LEARNED indicator will light up for about 1 seconds to indicate the completion of the erasure.

For the preset/learning keys, your programmed signal is erased and the originally preset signal resumes.

4. Repeat steps 2 and 3 for other keys, if necessary.

SPECIFICATIONS

■ AUDIO SECTION

Minimum RMS Output Power per Channel	
8 ohms, FRONT 20 Hz to 20 kHz, 0.05% THD	115W
8 ohms, REAR 1 kHz, 0.05% THD (SIMULATED or NATURAL surround)	20W
Damping Factor	
(8 ohms, 1 kHz)	50
Input Sensitivity/Impedance	
PHONO MM	2.5 mV/47 k-ohms
VIDEO	1 Vp-p/75 ohms
CD/TAPE/TUNER/AUX/LD/VCR/ ACCESSORY	150 mV/47 k-ohms
Maximum Input Level (1 kHz 0.01% THD)	
PHONO MM	130 mV
Output Level/Impedance	
REC OUT	150 mV/470 ohms
VIDEO	1 Vp-p/75 ohms
Headphone Jack Rated Output/Impedance	
8 ohms, 0.05% THD	0.8V/270 ohms
Frequency Response (20 Hz to 20 kHz)	
CD/TAPE/TUNER/AUX/LD/VCR/ ACCESSORY	0 ±0.5 dB
RIAA Equalization Deviation	
PHONO MM	±0.5 dB

Total Harmonic Distortion (20 Hz to 20 kHz)	
PHONO MM (3V)	0.008%
CD/TAPE/TUNER to SP OUT (50W/8 ohms)	0.05%
Signal to Noise Ratio (IHF-A Network)	
PHONO MM (5 mV Input Shorted)	80 dB
CD/TAPE/TUNER/AUX/LD/VCR/ACCESSORY (Shorted)	100 dB
Residual Noise	
(IHF-A Network)	150 μ V
Channel Separation (1 kHz, Vol. -30 dB)	
PHONO MM Input Shorted	60 dB
CD/TAPE/TUNER/AUX/LD/VCR/ACCESSORY Input 5.1 k-ohms Terminated	60 dB
Tone Control Characteristics	
BASS	
boost/cut	±10 dB (50 Hz)
turnover frequency	350 Hz
TREBLE	
boost/cut	±10 dB (20 kHz)
turnover frequency	3.5 kHz
BASS EXTENSION	75 Hz + 7 dB

■ GENERAL

Power Supply

U.S.A model 120V, 60 Hz

Australia model 240 V, 50 Hz

General model 110/120/220/240V, 50/60 Hz

Power Consumption 420W (550VA)

AC Outlets

Switched x 4 100W max. (Total)

Unswitched x 1 200W max.

Dimensions (W x H x D) 435 x 121 x 315.5 mm
(17-1/8" x 4-3/4" x 12-7/16")

Weight 10.2 kg (22 lbs. 8 oz.)

Accessories Remote control transmitter x 1
Battery (size "AA") x 2

Specifications subject to change without notice.



Manufactured under license from Dolby Laboratories Licensing Corporation. Additionally licensed under one or more of the following patents: U.S. numbers 3,632,886, 3,746,792, and 3,959,590; canada numbers 1,004,603 and 1,037,877. "Dolby" and the double-D symbol are trademarks of Dolby Laboratories Licensing Corporation.

TROUBLESHOOTING

If the unit fails to operate normally, check the following points to determine whether the fault can be corrected by the simple measures suggested. If it cannot be corrected, or if the fault is not listed in the SYMPTOM column, disconnect the power cord and contact your dealer or service center for help.

SYMPTOM	CAUSE	REMEDY
The amplifier fails to turn on when the POWER switch is pressed.	<ul style="list-style-type: none"> ● Power cord is not plugged in or is not completely inserted. 	<ul style="list-style-type: none"> ● Firmly plug in the power cord.
No sound.	<ul style="list-style-type: none"> ● Incorrect output cord connections. 	<ul style="list-style-type: none"> ● Connect cord properly. If the problem persists, the cords may be defective.
	<ul style="list-style-type: none"> ● Incorrect amplifier operation. 	<ul style="list-style-type: none"> ● Set the amplifier controls to the correct input selection.
Sound "hums".	<ul style="list-style-type: none"> ● Incorrect cord connections. 	<ul style="list-style-type: none"> ● Firmly connect the audio plugs. If the problem persists, the cord may be defective.
No picture.	<ul style="list-style-type: none"> ● Incorrect cord connections. ● Video unit not turned on. ● Wrong video unit selected. 	<ul style="list-style-type: none"> ● Connect the video plugs correctly. ● Turn video unit on. ● Select correct video unit.

YAMAHA
HAMAMATSU, JAPAN

YAMAHA CORPORATION
VH02820-0 BWgg.BR Printed in Japan. ©