



S30

MUSIC SYNTHESIZER

DATA LIST

DATEN-LISTE

LISTE DE DONNÉES

Contents

S30 Voice List	2
Quick Access Voice List	8
Drum Voice List	9
Wave List	12
Performance List	13
Control List	14
Arpeggio Type List	15
Effect Type List	16
Effect Parameter List	16
About MIDI	25
MIDI Data Format	25
MIDI Data Table	29
MIDI Implementation Chart	37



S30 Voice List

Preset 1 (MSB=63, LSB=0)

No.	Voice Name	Category	Reverb Type	Chorus Type	Insertion1 Type	Insertion2 Type	MW	PB	AT	FC	BC	FS	Kn1	Kn2
1(A01)	StereoGrnd	Pf	Hall 1	Chorus 1	3band EQ	Thru	ChoSend	off	off	off	off	off	ChoSend	RevSend
2(A02)	StereoGnd2	Pf	Hall 1	Chorus 1	3band EQ	Thru	ChoSend	off	off	off	off	off	FLT-Frq	RevSend
3(A03)	CF Grand M	Pf	Hall 1	Chorus 1	3band EQ	Thru	ChoSend	off	off	off	off	off	ChoSend	RevSend
4(A04)	Dark Grand	Pf	Hall 1	Chorus 1	Thru	Thru	ChoSend	off	off	off	off	off	FLT-Frq	RevSend
5(A05)	Difference	Pf	Hall 1	Chorus 1	3band EQ	Thru	ChoSend	off	off	off	off	off	FLT-Frq	RevSend
6(A06)	Piano/Ep	Pf	Hall 1	Chorus 1	Chorus 1	3Band EQ	ChoSend, Volume	off	off	off	off	off	FLT-Frq	ELM-Lvl, ELM-Lvl
7(A07)	Piano/Strg	Co	Hall 1	Chorus 1	3band EQ	Thru	ELM-Lvl	off	off	off	off	off	FLT-Frq	RevSend
8(A08)	Piano/Oohs	Pf	Hall 1	Chorus 1	3band EQ	Thru	ELM-Lvl	off	off	off	off	off	FLT-Frq	RevSend
9(A09)	CP2000	Pf	Hall 1	Flanger 3	3band EQ	Thru	ChoSend	off	off	off	off	off	ELM-Lvl	FLT-Frq
10(A10)	Piano/DX	Pf	Hall 1	Chorus 1	3band EQ	Chorus 5	CLFO-D1	off	off	off	off	off	ChoSend, Volume	RevSend
11(A11)	Wurlftrm	Pf	Room 1	Celeste 1	Thru	Tremolo	Insl_prm2, Volume	off	off	off	off	off	FLT-Frq	ChoSend, RevSend
12(A12)	DF EP IV	Pf	Hall 1	Chorus 1	3band EQ	Pitch Change 1	InsS prm2	off	off	off	off	off	FLT-Frq	ChoSend, RevSend
13(A13)	DF EP III	Pf	Hall 2	Chorus 1	Compressor	Celeste 1	Insl_prm3, Insl_prm1	off	off	off	off	off	Insl_prm10	RevSend
14(A14)	Herb Roadz	Pf	Hall 2	Chorus 1	Auto Pan	Comp Distortion	InsS prm1	off	off	off	off	off	InsS prm2	RevSend
15(A15)	BasicRoadz	Pf	Hall 2	Chorus 1	3band EQ	Auto Pan	Insl_prm1	off	off	off	off	off	Insl_prm2	ChoSend, RevSend
16(A16)	19 Roadz	Pf	Stage 2	Chorus 1	Compressor	Phaser 1	Insl_prm2	off	off	off	off	off	Insl_prm4	RevSend
17(B01)	Vic'sRoadz	Pf	Hall 1	Celeste 2	3band EQ	Auto Pan	Insl_prm2, Insl_prm1	off	off	off	off	off	ChoSend	RevSend
18(B02)	ErlyFusion	Pf	Hall 1	Phaser	Touch Wah	3Band EQ	CLFO-D1	off	off	off	off	off	RevSend	ChoSend
19(B03)	Grapevine	Pf	Room 2	Chorus 1	Auto Pan	V-Distortion	ELFO-PM	off	off	off	off	off	AEG-D1	RevSend
20(B04)	VintgCond	Pf	Hall 1	Chorus 1	3band EQ	Auto Pan	Insl_prm1, Insl_prm2, Insl_prm3	off	off	off	off	off	RevSend	ChoSend
21(B05)	DXAtacky	Pf	Hall 1	Celeste 1	Chorus 3	Thru	CLFO-D1	off	off	off	off	off	RevSend	ChoSend
22(B06)	DigiX Wave	Pf	Hall 1	Chorus 5	3band EQ	Thru	CLFO-D1	off	off	off	off	off	RevSend	ChoSend
23(B07)	Dark DX	Pf	Hall 1	Chorus 1	Thru	Thru	CLFO-D1	off	off	off	off	off	FLT-Frq	ChoSend, RevSend
24(B08)	Ice Piano	Pf	Hall 1	Chorus 1	Thru	Thru	CLFO-D1	off	off	off	off	off	FLT-Frq	ChoSend, RevSend
25(B09)	ChorusBel	Pf	Stage 1	Delay LR	3band EQ	Ensemble Detune	Insl_prm10	off	off	off	off	off	RevSend	ChoSend
26(B10)	Bel Roadz	Pf	Hall 1	Chorus 4	Thru	Thru	ELFO-AM	off	off	off	off	off	RevSend	ELFOSpd
27(B11)	Glass EP	Pf	Hall 1	Chorus 1	Thru	Thru	ELFO-AM	off	off	off	off	off	RevSend	ChoSend
28(B12)	SuperDyno	Pf	Hall 1	Chorus 1	Compressor	Pitch Change 1	Insl_prm11, Insl_prm13 Insl_prm2, Insl_prm4, Insl_prm10	off	off	off	off	off	InsS prm4, InsS prm3	RevSend
29(B13)	PowerKeys	Sc	Room 1	Chorus 1	3band EQ	Phaser 2	Insl_prm1	off	off	off	off	off	Insl_prm1	RevSend
30(B14)	Harpicorde	Pf	Room 3	Celeste 1	Thru	Thru	ChoSend, Volume	off	off	off	off	off	FLT-Frq	FEG-D1
31(B15)	Clav	Pf	Stage 2	Celeste 1	Thru	Thru	ChoSend, Volume	off	off	off	off	off	FLT-Frq	AEG-D1, AEG-D2
32(B16)	Clav Wah	Pf	Stage 2	Phaser	Touch Wah	Thru	ChoSend, Volume	RevSend	off	off	off	off	FLT-Frq	FEG-D1
33(C01)	Perc Org	Or	Hall 1	Chorus 1	3band EQ	2Way Rotary Speaker 3	Insl_prm16, ChoSend, ELM-Lvl	off	off	off	off	off	Insl_prm9	RevSend
34(C02)	Cool	Or	Room 1	Chorus 1	Thru	2Way Rotary Speaker 3	Insl_prm16	off	off	off	off	off	Insl_prm9	Insl_prm1
35(C03)	ClickOrgan	Or	Hall 1	Chorus 1	Overdrive	Rotary Speaker 1	Insl_prm1	off	off	off	off	off	ELM-Lvl	ELM-Lvl
36(C04)	Jazz	Or	Room 1	Chorus 1	Overdrive	Rotary Speaker 1	Insl_prm1	off	off	off	off	off	Insl_prm9	Insl_prm1
37(C05)	Soft Rock	Or	Hall 1	Chorus 1	Overdrive	Rotary Speaker 1	Insl_prm1, ChoSend, ELM-Lvl	off	off	off	off	off	InsS prm10	ChoSend
38(C06)	Tube	Or	Hall 1	Chorus 3	AMP Simulator	2Way Rotary Speaker 3	Insl_prm16, Insl_prm9	off	off	off	off	off	InsS prm1, Volume	Insl_prm9, FLT-Frq
39(C07)	Continental	Or	Stage 1	Chorus 1	3band EQ	2Way Rotary Speaker	Insl_prm1	off	off	off	off	off	FLT-Frq	RevSend
40(C08)	Swish	Or	Room 1	Chorus 1	Thru	Thru	ChoSend, Volume	off	off	off	off	off	FLT-Frq	RevSend
41(C09)	4 Bars	Or	Hall 1	Chorus 1	Overdrive	Rotary Speaker 1	Insl_prm1	off	off	off	off	off	RevSend	ELM-Lvl
42(C10)	Full	Or	Hall 1	Chorus 1	3band EQ	2Way Rotary Speaker 3	Insl_prm16, ChoSend, ELM-Lvl	off	off	off	off	off	ELM-Lvl	ELM-Lvl
43(C11)	GiantDrbr	Or	Room 1	Chorus 1	Thru	2Way Rotary Speaker 3	Insl_prm16	Insl_prm2, Insl_prm3	off	off	off	off	Insl_prm14	Insl_prm5, Insl_prm6
44(C12)	Sunday	Or	Hall 2	Chorus 3	2band EQ	Thru	FLT-Frq	off	off	off	off	off	ELM-Lvl	RevSend
45(C13)	Pipes	Or	Hall 2	Chorus 3	Thru	Thru	ChoSend	off	off	off	off	off	RevSend	ELFO-PM
46(C14)	New Nylon	Gt	Hall 1	Chorus 1	3band EQ	Thru	CLFO-D1	off	off	off	off	off	ELM-Lvl	ELM-Lvl, FLT-Frq
47(C15)	JazzGTrmelo	Gt	Hall 1	Chorus 1	3band EQ	3Band EQ	CLFO-D1	off	off	off	off	off	InsS prm4	ChoSend
48(C16)	Melo Trmlo	Gt	Hall 1	Delay LR	Tremolo	Comp Distortion	FLT-Frq	off	off	off	off	off	InsS prm1	InsS prm2
49(D01)	Strat Chor	Gt	Hall 1	Delay LR	Chorus 1	Comp Distortion	ELFO-PM	off	off	off	off	off	Insl_prm1, Insl_prm4, Volume, Insl_prm14	InsS prm10
50(D02)	StratChor2	Gt	Hall 1	Chorus 4	3band EQ	AMP Simulator	ELFO-PM	off	off	off	off	off	ChoSend, Volume	RevSend
51(D03)	18 String	Gt	Hall 2	Chorus 1	3band EQ	2Band EQ	CLFO-D1	off	off	off	off	off	ChoSend	FLT-Frq
52(D04)	Acoustic	Gt	Hall 1	Chorus 1	Thru	Thru	ELFO-PM	off	off	off	off	off	FEG-D1	ChoSend
53(D05)	MuteGr	Gt	Room 3	Phaser	Thru	Compressor	ELFO-PM, ChoSend	off	off	off	off	off	RevSend	FLT-Frq, FLT-Rez
54(D06)	DirtyTwn	Gt	Room 3	Chorus 4	3band EQ	V-Distortion	ELFO-PM	off	off	off	off	off	Insl_prm1	Insl_prm11, RevSend
55(D07)	Feedback	Gt	Room 3	Chorus 4	3band EQ	V-Distortion	ELFO-PM	off	off	off	off	off	Insl_prm1	Insl_prm11, RevSend
56(D08)	VOODOO MAN	Gt	Room 3	Phaser	Touch Wah	V-Distortion	ELFO-PM, InsS prm4	off	InsS prm2	off	off	off	Insl_prm1	Insl_prm11
57(D09)	Rockabilly	Gt	Room 3	Chorus 4	3band EQ	V-Distortion	ELFO-PM	off	off	off	off	off	Insl_prm1, Volume	Insl_prm11, RevSend
58(D10)	Funk It!	Gt	Room 3	Delay LR	Compressor	Auto WAH Overdrive	FLT-Frq	off	off	off	off	off	InsS prm3, Volume	ChoSend
59(D11)	Upright	Ba	Room 1	Chorus 1	3band EQ	Thru	ELFO-PM	off	off	off	off	off	FLT-Frq, FLT-Frq	ELM-Lvl
60(D12)	Finger	Ba	Room 3	Chorus 4	Compressor	Thru	CLFO-D1	off	off	off	off	off	InsS prm3, Volume	ChoSend
61(D13)	PickBass	Ba	Room 1	Chorus 1	Thru	Thru	ELFO-PM	off	off	off	off	off	FLT-Frq	ChoSend, RevSend
62(D14)	Fretless	Ba	Hall 1	Chorus 1	3band EQ	Thru	ELFO-PM	off	off	off	off	off	FLT-Frq	ChoSend, RevSend
63(D15)	Slap	Ba	Room 1	Chorus 1	Compressor	Thru	ELFO-PM	off	off	off	off	off	FLT-Frq	ChoSend, RevSend
64(D16)	Fngr & RW	Ba	Room 1	Chorus 1	Thru	Thru	ELFO-PM	off	ELFO-PM	off	off	off	FLT-Frq, FLT-Frq	ChoSend, RevSend

No.	Voice Name	Category	Reverb Type	Chorus Type	Insertion1 Type	Insertion2 Type	MW	PB	AT	FC	BC	FS	Kn1	Kn2
65(E01)	Background	St	Hall 2	Chorus 1	3band EQ	3Band EQ	CLFO-D1	off	off	off	off	off	ChoSend, RevSend	AEG-Atk, AEG-Rel
66(E02)	Big String	St	Hall 1	Chorus 1	Thru	Thru	ELFO-PM	off	off	off	off	off	RevSend	FLT-Frq, FLT-Rez
67(E03)	Cello Big	St	Hall 1	Chorus 1	Thru	Thru	FLT-Frq	off	off	off	off	off	AEG-Rel, AEG-Atk	ChoSend, RevSend
68(E04)	Chamberz	St	Hall 1	Chorus 1	Thru	Thru	ELFO-PM	off	off	off	off	off	RevSend	FLT-Frq, FLT-Rez
69(E05)	SmallSect	St	Hall 1	Chorus 1	3band EQ	Thru	ChoSend, Volume	off	off	off	off	off	FLT-Frq	AEG-Atk, AEG-Rel
70(E06)	CelloSmall	St	Hall 1	Chorus 1	Thru	Thru	FLT-Frq	off	off	off	off	off	AEG-Rel, AEG-Atk	ChoSend, RevSend, Volume
71(E07)	Pizz	St	Hall 1	Chorus 3	Thru	Thru	ChoSend	off	off	off	off	off	FLT-Frq	AEG-D1
72(E08)	Harp	St	Hall 1	Celeste 2	Thru	Thru	ELFO-PM	off	off	off	off	off	RevSend	ChoSend
73(E09)	Oboe	Rd	Hall 1	Chorus 1	Thru	Thru	ELFO-PM, ELFO-AM	off	off	off	off	off	RevSend	FLT-Frq
74(E10)	Bssoon	Rd	Hall 1	Chorus 1	Thru	Thru	ELFO-PM	ELFO-AM	off	off	off	off	RevSend	FLT-Frq
75(E11)	Ciarnet	Rd	Hall 1	Chorus 1	3band EQ	Thru	ELFO-PM, ELFO-AM	off	off	off	off	off	RevSend	FLT-Frq, FLT-Rez
76(E12)	Wind Orch	Co	Hall 1	Ensemble	3band EQ	Thru	CLFO-D1, CLFO-D2, ELFO-PM, ELFO-FM	off	off	off	off	off	FLT-Frq	ELM-Lvl
77(E13)	SynthStrgs	St	Hall 1	Chorus 1	3band EQ	Cross Delay	FLT-Frq	off	off	off	off	off	ChoSend, Volume	RevSend
78(E14)	ObiStrings	St	Hall 2	Chorus 5	Exciter	Cross Delay	FLT-Frq, FLT-Rez	off	off	off	off	off	InsS prm1	ChoSend
79(E15)	Fanfare	Br	Hall 1	Chorus 1	3band EQ	Thru	CLFO-D1	off	off	off	off	off	ChoSend, Volume	RevSend
80(E16)	MediumBrss	Br	Hall 1	Chorus 1	3band EQ	Thru	CLFO-D1	off	off	off	off	off	ChoSend, Volume	RevSend
81(F01)	Two Brass	Br	Hall 1	Chorus 1	Thru	Thru	ELFO-FM, ELFO-PM	off	off	off	off	off	FLT-Frq	ChoSend, Volume
82(F02)	Brass&Sax	Br	Hall 1	Chorus 1	Thru	Thru	ELFO-FM, ELFO-PM	off	off	off	off	off	FLT-Frq	ChoSend, Volume
83(F03)	Dark Class	Br	Hall 1	Chorus 1	Thru	Thru	ELFO-FM, ELFO-PM	off	off	off	off	off	FLT-Frq	ChoSend, Volume
84(F04)	Stereo Brs	Br	Hall 1	Chorus 1	Thru	Thru	ELFO-FM, ELFO-PM	off	off	off	off	off	FLT-Frq	ChoSend, Volume
85(F05)	Trumpet	Br	Hall 1	Ensemble	Thru	Delay LCR	ELFO-PM, ELFO-FM	off	off	off	off	off	RevSend	ChoSend, FLT-Rez
86(F06)	Mute Trpt	Br	Hall 1	Chorus 1	3band EQ	Thru	ELFO-PM	ELFO-AM	off	off	off	off	RevSend	HPF-Frq
87(F07)	Tenor Sax	Rd	Hall 1	Chorus 1	3band EQ	Thru	ELFO-PM, ELFO-AM	off	off	off	off	off	FLT-Frq	ChoSend
88(F08)	Alto Sax	Rd	Hall 1	Chorus 1	3band EQ	Thru	ELFO-PM, ELFO-AM	off	off	off	off	off	FLT-Frq	ChoSend
89(F09)	Bari Sax	Rd	Hall 1	Chorus 1	3band EQ	Thru	ELFO-PM, ELFO-FM	off	off	off	off	off	FLT-Frq	ChoSend
90(F10)	Soprano	Rd	Hall 1	Delay LR	3band EQ	Thru	ELFO-PM	off	off	off	off	off	RevSend	ChoSend
91(F11)	ObBrass	Br	Hall 1	Chorus 4	3band EQ	Chorus 4	CLFO-D1	off	off	off	off	off	RevSend	FLT-Frq, FLT-Rez
92(F12)	PowerSynth	Br	Hall 1	Chorus 1	3band EQ	Harmonic Enhancer	CLFO-D1	off	off	off	off	off	InsL prm3	RevSend
93(F13)	Synth Horn	Br	Hall 2	Chorus 1	Thru	Tempo Cross Delay	FLT-Frq, ChoSend, RevSend	off	off	off	off	off	InsL prm10	FLT-Rez
94(F14)	M Brass	Br	Hall 1	Delay LR	Thru	Thru	ELFO-PM	off	off	off	off	off	FLT-Frq, FLT-Rez	PEG-Dpt, PEG-Atk
95(F15)	Moon AT	Br	Hall 1	Chorus 1	3band EQ	Harmonic Enhancer	CLFO-D1	off	FLT-Frq, Volume	off	off	off	PCH-Crs	RevSend
96(F16)	SquishBrs	Br	Hall 1	Chorus 1	Thru	Thru	ELFO-PM	off	off	off	off	off	FLT-Rez	RevSend, ChoSend
97(G01)	Ooh Choir	Vo	Hall 2	Delay LR	Exciter	3Band EQ	CLFO-D1	off	off	off	off	off	AEG-Atk, AEG-Rel	RevSend, ChoSend
98(G02)	Ahh Choir	Vo	Hall 2	Delay LR	3band EQ	Talking Modulator	CLFO-D1	off	off	off	off	off	AEG-Atk, AEG-Rel	RevSend, ChoSend
99(G03)	Panmonks	Vo	Plate	Delay LR	Tremolo	Ensemble Detune	InsS prm2	off	off	off	off	off	AEG-Rel	RevSend, ChoSend
100(G04)	Pad Ooh	En	Hall 1	Ensemble	Chorus 1	Thru	InsS prm10, ChoSend	off	off	off	off	off	FLT-Frq	AEG-Atk, AEG-Rel
101(G05)	Soft Pad	Pd	Hall 1	Chorus 1	Thru	V-Flanger	InsL prm14	off	off	off	off	off	ELM-Lvl	ChoSend
102(G06)	FatSweep	Pd	Hall 2	Symphonic	Chorus 4	Cross Delay	ELFO-PM	off	off	off	off	off	ChoSend	InsL prm10
103(G07)	Cumulus	Pd	Hall 1	Delay LR	Celeste 3	Harmonic Enhancer	ELFO-FM	off	off	off	off	off	RevSend	ChoSend
104(G08)	Big Wing	Pd	Stage 1	Ensemble	Celeste 4	Harmonic Enhancer	ELM-Lvl	off	off	off	off	off	InsL prm3	RevSend
105(G09)	Slide in	Pd	Hall 1	Chorus 1	Thru	Thru	ELFO-PM	off	off	off	off	off	PEG-Atk	ChoSend
106(G10)	BPFx	Pd	Hall 2	Ensemble	Chorus 4	Cross Delay	CLFO-D1, ELM-Lvl	off	CLFO-D1	off	off	off	FEG-Dpt	InsL prm10
107(G11)	DigiSweep	Pd	Hall 2	Chorus 5	Compressor	Tempo Cross Delay	FLT-Frq, FEG-Dpt, RevSend	off	off	off	off	off	ChoSend	RevSend
108(G12)	JM Pad	Pd	Hall 2	Chorus 4	Thru	Phaser 2	ELFO-PM, InsL prm1, InsL prm2	off	off	off	off	off	FLT-Frq	FLT-Rez
109(G13)	Vermillion	Pd	Hall 1	Tempo Delay2	Thru	Pitch Change 1	ELFO-PM	off	off	off	off	off	FLT-Frq	ChoSend, RevSend
110(G14)	Magenta	Pd	Hall 1	Chorus 1	Flanger 1	Delay LCR	ELFO-PM, FLT-Frq	off	ELFO-PM	off	off	off	FLT-Frq	RevSend, ChoSend
111(G15)	Liquito	Sc	Hall 1	Chorus 1	Compressor	V-Flanger	AEG-Rel, FLT-Frq, AEG-D1	off	off	off	off	off	FLT-Rez	ChoSend, RevSend
112(G16)	Shadow	Fx	Hall 2	Flanger 1	Celeste 4	Jump	InsL prm2, ChoSend	off	off	off	off	off	FLT-Frq	InsL prm9
113(H01)	Vibes	Cp	Hall 1	Celeste 2	Thru	3Band EQ	ChoSend	off	off	off	off	off	ELFO-AM	ELFOSpd
114(H02)	Marimba	Cp	Hall 1	Celeste 2	Thru	Thru	ELFO-AM	off	off	off	off	off	FLT-Frq, FLT-Rez	RevSend, ChoSend
115(H03)	Gamelan	Cp	Hall 1	Symphonic	Thru	Thru	ChoSend	off	off	off	off	off	FLT-Frq	AEG-Atk, AEG-Rel
116(H04)	Xylo	Cp	Hall 1	Celeste 2	Thru	Thru	ELFO-FM	off	off	off	off	off	RevSend	ChoSend
117(H05)	Glocken	Cp	Hall 2	Celeste 2	Thru	Thru	ChoSend	off	off	off	off	off	RevSend	ELFO-PM
118(H06)	Crotales	Cp	Hall 1	Celeste 2	Thru	Thru	FLT-Frq	off	off	off	off	off	FLT-Frq	RevSend
119(H07)	Timpani	Pc	Hall 1	Celeste 2	Thru	Thru	ELFO-AM	off	off	off	off	off	AEG-Atk	FLT-Frq
120(H08)	SteelDrum	Cp	Hall 1	Celeste 2	Thru	Thru	ELFO-FM, ChoSend	off	off	off	off	off	AEG-Rel	RevSend
121(H09)	Sitar	Et	Hall 1	Flanger 1	3band EQ	Ensemble Detune	ELFO-PM	off	off	off	off	off	ChoSend	RevSend
122(H10)	BrthFlute	Pi	Hall 1	Chorus 1	Thru	Thru	CLFO-D1, CLFO-D2	off	off	off	off	off	FLT-Frq	ELM-Lvl
123(H11)	Pan Flute	Pi	Hall 1	Chorus 1	Thru	Thru	ELFO-AM, ELFO-FM	off	off	off	off	off	FLT-Frq, FLT-Rez	AEG-Atk
124(H12)	Accordion	Or	Hall 1	Ensemble	Thru	Thru	ChoSend	off	off	off	off	off	HPF-Frq	FLT-Frq
125(H13)	Monica	Rd	Stage 1	Ensemble	AMP Simulator	Touch WAH	ELFO-PM	FLT-Frq	ELFO-PM	off	off	off	ChoSend	RevSend
126(H14)	BluesHarp	Rd	Stage 2	Chorus 1	Touch Wah	V-Distortion	ELFO-AM, CLFO-D1, ELFO-PM	FLT-Frq	off	off	off	off	InsL prm1	RevSend
127(H15)	Amandla	Co	Stage 1	Delay LR	2band EQ	Celeste 4	ELFO-PM	off	ELFO-PM	off	off	off	RevSend	ChoSend
128(H16)	AnalogSplit	Co	Hall 1	Chorus 1	Phaser	Tempo Delay 2	ELFO-PM	off	ELFO-PM	off	off	off	InsS prm1	InsL prm10

Preset 2 (MSB=63, LSB=1)

No.	Voice Name	Category	Reverb Type	Chorus Type	Insertion1 Type	Insertion2 Type	MW	PB	AT	FC	BC	FS	Kn1	Kn2
1(A01)	1001 Sub	Ba	Stage 2	Ensemble	Thru	Echo	ChoSend, ELM-Lvl	off	off	off	off	off	FLT-Frq, FEG-D1	InsL_prm10
2(A02)	Trancy	Ba	Hall 1	Chorus 4	Thru	Delay LR	ChoSend, ELM-Lvl	off	off	off	off	off	FEG-Atk	InsL_prm10
3(A03)	Velo	Ba	Stage 2	Chorus 1	Thru	Auto WAH	InsL_prm10, RevSend	off	off	off	off	off	FEG-Atk	ChoSend
4(A04)	Wonk	Ba	Hall 1	Ensemble	3band EQ	Thru	ELFO-PM	off	off	off	off	off	FLT-Rez	RevSend, ChoSend
5(A05)	Mini 1	Ba	Room 1	Chorus 1	3band EQ	Pitch Change 1	ELFO-PM	off	off	off	off	off	InsL_prm10	RevSend
6(A06)	Mini 2	Ba	Room 1	Chorus 1	3band EQ	Pitch Change 1	ELFO-PM	off	off	off	off	off	InsL_prm10	RevSend
7(A07)	D-sub	Ba	Hall 1	Flanger 1	Thru	Thru	ELFO-PM	off	off	off	off	off	FLT-Frq	ChoSend
8(A08)	Lately	Ba	Room 3	Control Delay1	Compressor	AMP Simulator	ELFO-PM	off	off	off	off	off	InsL_prm10	ELFOSpd
9(A09)	Dark	Ba	Stage 2	Chorus 1	Thru	Thru	FLT-Frq	off	off	off	off	off	FEG-Atk, FEG-D1	ChoSend, ELM-Lvl
10(A10)	Moonbass	Ba	Hall 1	Flanger 1	Thru	Thru	ELFO-PM	off	off	off	off	off	FLT-Frq	ChoSend
11(A11)	Snoop Bs	Ba	Hall 1	Phaser	3band EQ	Thru	ELFO-PM	off	off	off	off	off	FLT-Frq	ChoSend, RevSend
12(A12)	LoTic Bass	Ba	Room 1	Chorus 1	Thru	Chorus 1	ELFO-PM, Volume	off	ELFO-PM	off	off	off	AEG-Atk, AEG-Rel	ChoSend
13(A13)	Taurus	Ba	Hall 1	Flanger 1	Thru	Thru	ELFO-PM	off	off	off	off	off	FLT-Frq, FLT-Rez	ChoSend
14(A14)	Fuzzline	Ba	Hall 1	Phaser	Distortion	Delay LR	ChoSend, ELM-Lvl	off	off	off	off	off	InsS_prm10, ELM-Lvl	InsL_prm10
15(A15)	Deep One	Ba	Hall 1	Chorus 1	Thru	Thru	ELFO-PM	off	off	off	off	off	FLT-Frq	FLT-Rez
16(A16)	Squabase	Ba	Hall 1	Tempo Cross Delay	Flanger 1	Thru	ELFO-FM, ELM-Lvl	off	off	off	off	off	InsS_prm10, ChoSend	InsS_prm3
17(B01)	Portachrd	Sc	Hall 1	Chorus 4	Thru	Delay LR	FLT-Rez, FLT-Frq, ChoSend	off	off	off	off	off	FEG-Atk	ChoSend
18(B02)	Thin man	Sc	Hall 2	Ensemble	Compressor	Cross Delay	FLT-Frq	off	off	off	off	off	AEG-Atk, AEG-Rel	ChoSend, ELM-Lvl
19(B03)	PopularSyn	Sc	Hall 1	Chorus 1	Auto Wah	Cross Delay	InsS_prm2	off	off	off	off	off	ChoSend	InsL_prm10
20(B04)	Straight	Sc	Hall 1	Ensemble	Celeste 4	Cross Delay	ELFO-PM	off	off	off	off	off	FLT-Rez, InsS_prm1	AEG-Rel, FLT-Rez
21(B05)	Poly	Sc	Hall 1	Ensemble	Auto Wah	Delay LR	ELFO-PM	off	off	off	off	off	FLT-Frq, FEG-Dpt	InsS_prm9
22(B06)	Zap Comp	Sc	Hall 1	Chorus 1	Touch Wah	Cross Delay	ELFO-PM	off	off	off	off	off	FLT-Rez	RevSend, ChoSend
23(B07)	AnaTonk	Sc	Hall 1	Chorus 1	Thru	Thru	ELFO-PM	off	off	off	off	off	FEG-D1, FEG-D2	ChoSend
24(B08)	Insomnia	Sc	Hall 1	Tempo Phaser	Compressor	Thru	FLT-Frq	off	off	off	off	off	ELM-Lvl	RevSend
25(B09)	Q Hit	Sc	White Room	Control Delay1	Exciter	Gate Reverb	ELFO-PM	off	off	off	off	off	ELM-Lvl, FLT-Frq	RevSend
26(B10)	BPF1	Sc	Hall 1	Chorus 1	Thru	Thru	CLFO-D1	off	off	off	off	off	FLT-Frq, FLT-Frq	FEG-Atk
27(B11)	T-Eight	Sc	Hall 1	Delay LR	Chorus 1	Compressor	ELFO-PM, CLFOSpd, InsS_prm10	off	off	off	off	off	FLT-Frq, FEG-Dpt	FEG-Atk
28(B12)	L7 octs	Sc	Hall 1	Celeste 3	Thru	Thru	ELFO-PM	off	off	off	off	off	FLT-Frq	ChoSend, Volume
29(B13)	NoizRezz	Sc	Hall 1	Chorus 2	Thru	Tempo Cross Delay	ELFO-PM	off	off	off	off	off	InsL_prm10, ChoSend	RevSend
30(B14)	GX	Sc	Hall 1	Celeste 4	Thru	Thru	CLFO-D1	off	off	off	off	off	FLT-Frq	ChoSend, RevSend
31(B15)	Noise Harp	Sc	Room 3	Celeste 2	Thru	Hall 1	ELFO-PM	off	off	off	off	off	ChoSend	RevSend
32(B16)	Syntax	Ld	Hall 1	Ensemble	Flanger 3	Delay LCR	FLT-Frq	off	off	off	off	off	InsS_prm10	ChoSend
33(C01)	Tri Solo	Ld	Hall 1	Delay LR	3band EQ	Thru	ELFO-PM	off	off	off	off	off	FLT-Frq	ChoSend, Volume, RevSend
34(C02)	Smooth Saw	Ld	Hall 1	Delay LR	Thru	Thru	ELFO-PM	off	off	off	off	off	FLT-Frq	ChoSend, Volume, RevSend
35(C03)	Frontline	Ld	Hall 1	Ensemble	Distortion	Cross Delay	ChoSend, ELM-Lvl	off	off	off	off	off	PCH-Fin	ChoSend
36(C04)	Lucky	Ld	Hall 1	Chorus 3	Thru	Thru	ELFO-PM	off	off	off	off	off	FLT-Frq	ChoSend, Volume
37(C05)	Sneaky	Ld	Hall 1	Chorus 1	Thru	Thru	ELFO-PM	off	off	off	off	off	FEG-Dpt	FLT-Rez
38(C06)	Rap Lead 1	Ld	Hall 1	Chorus 1	Thru	Thru	ELFO-PM	off	off	off	off	off	FLT-Frq	FLT-Rez
39(C07)	Rap Lead 2	Ld	Hall 1	Chorus 1	Thru	Thru	ELFO-PM	off	off	off	off	off	FLT-Frq	FLT-Rez
40(C08)	Rap Lead 3	Ld	Hall 1	Chorus 1	Thru	Thru	ELFO-PM	off	off	off	off	off	FLT-Frq	FLT-Rez
41(C09)	PhazFilter	Ld	Hall 1	Tempo Phaser	Chorus 1	Ensemble Detune	ELFO-PM	off	off	off	off	off	InsS_prm10, InsL_prm10, InsS_prm2	PEG-Dpt
42(C10)	SpaceWhirl	Ld	Tunnel	Tempo Delay2	Compressor	Tempo Phaser	InsL_prm10, FLT-Frq, AEG-Rel	off	off	off	off	off	RevSend	ChoSend
43(C11)	X-File	Ld	Stage 1	Delay LR	Thru	V-Flanger	ELFO-PM	off	off	off	off	off	PorTime	RevSend
44(C12)	BreathSaw	Ld	Hall 1	Delay LR	2band EQ	Ambience	CLFO-D1, CLFO-D2	off	off	off	off	off	ELM-Lvl	RevSend
45(C13)	1 is more	Ld	Hall 1	Ensemble	Thru	Delay LR	ELFO-PM	off	off	off	off	off	ChoSend	AEG-Atk
46(C14)	Mini Pulse	Ld	Hall 2	Chorus 2	Compressor	Tempo Cross Delay	ELFO-PM	off	off	off	off	off	ChoSend	RevSend, InsL_prm10
47(C15)	Syntrump	Ld	Hall 1	Tempo Delay1	Thru	Thru	ELFO-PM	off	off	off	off	off	FLT-Frq	ChoSend
48(C16)	Eagle	Ld	Hall 1	Tempo Delay1	Thru	Thru	ELFO-PM	off	off	off	off	off	FLT-Frq	ChoSend
49(D01)	Oberweich	Pd	Hall 1	Chorus 1	Thru	Thru	CLFO-D1	off	off	off	off	off	ChoSend	RevSend
50(D02)	5thBreath	Pd	Hall 2	Ensemble	Exciter	Cross Delay	CLFO-D1	off	off	off	off	off	FLT-Frq, FLT-Rez	InsL_prm10
51(D03)	Rain Pad	Pd	Hall 1	Chorus 1	Thru	Thru	ChoSend, Volume	off	off	off	off	off	FLT-Rez	ELM-Lvl, ELM-Lvl
52(D04)	Vortex	Pd	White Room	Chorus 1	Flanger 3	Thru	ELFO-PM, ELFO-FM	off	off	off	off	off	PEG-Dpt	InsS_prm1
53(D05)	Sprinkler	Pd	Hall 1	Chorus 1	Thru	V-Flanger	PCH-Crs, Volume	off	off	off	off	off	ELM-Lvl	AEG-Atk, AEG-Rel
54(D06)	Astronaut	Pd	Stage 1	Celeste 4	Phaser	Ambience	FLT-Frq	off	off	off	off	off	ChoSend	RevSend, InsL_prm10
55(D07)	BrassyPad	Pd	Hall 1	Delay LR	Chorus 1	V-Flanger	ELM-Lvl	off	off	off	off	off	FLT-Frq	InsL_prm14, InsL_prm2
56(D08)	Sine Pad	Pd	Hall 2	Chorus 1	Thru	Symphonic	CLFO-D1	off	off	off	off	off	ChoSend	RevSend
57(D09)	Big Syn	St	Hall 2	Chorus 5	Exciter	Cross Delay	FLT-Frq, FLT-Rez	off	off	off	off	off	ELM-Lvl	ELM-Lvl
58(D10)	Berlin	Sc	Hall 2	Flanger 3	Chorus 4	Cross Delay	ChoSend, ELM-Lvl, FLT-Frq	off	off	off	off	off	FLT-Frq	PEG-Dpt
59(D11)	Filtopia	Sc	Hall 1	Chorus 1	Compressor	Hall 2	ELM-Lvl, ChoSend, FLT-Frq	off	off	off	off	off	FEG-Atk	FLT-Frq
60(D12)	Poppy Vox	Sc	Hall 1	Symphonic	Exciter	Hall 1	ELFO-PM	FLT-Frq	off	off	off	off	ChoSend	RevSend
61(D13)	Arabesque	Sc	Hall 1	Chorus 1	Compressor	Hall 2	FLT-Frq, ELM-Lvl, ELM-Pan	off	off	off	off	off	InsL_prm13	AEG-D1
62(D14)	Crecendar	Sc	Hall 1	Chorus 1	Flanger 1	Delay LCR	ELFO-PM, FLT-Frq	off	ELFO-PM, InsS_prm1	off	off	off	FLT-Frq	FLT-Rez
63(D15)	Soft Dream	Co	Hall 2	Symphonic	Celeste 4	Thru	CLFO-D1, ChoSend	off	off	off	off	off	FLT-Frq	ChoSend
64(D16)	ChimzArt	Co	Hall 1	Chorus 1	Compressor	Hall 2	ELM-Lvl, ELM-Lvl, Volume	off	off	off	off	off	ChoSend	ELM-Pan

No.	Voice Name	Category	Reverb Type	Chorus Type	Insertion1 Type	Insertion2 Type	MW	PB	AT	FC	BC	FS	Kn1	Kn2
65(E01)	Seal	Sq	Hall 2	Tempo Cross Delay	Chorus 4	Ensemble Detune	FLT-Rez, ELM-Lvl	off	off	off	off	off	ELM-Lvl	ChoSend
66(E02)	Shine Seq	Sq	Hall 1	Tempo Cross Delay	Chorus 1	Ensemble Detune	FLT-Rez	off	off	off	off	off	FLT-Frq, ELM-Lvl, CLFO-D1	FLT-Rez
67(E03)	Kickwheel	Sq	Hall 1	Tempo Flanger	Distortion	Delay LR	ELM-Lvl, ChoSend	off	off	off	off	off	InsL_prm10, ELM-Lvl	HPF-Frq
68(E04)	Supersnap	Sq	Hall 1	Phaser	Compressor	Delay LR	ELM-Lvl	off	off	off	off	off	ELM-Lvl	ChoSend, InsL_prm10
69(E05)	Opener	Sq	Hall 1	Tempo Cross Delay	Chorus 4	Tempo Phaser	FLT-Frq, InsL_prm10	off	off	off	off	off	FEG-Atk	ChoSend, InsL_prm10
70(E06)	Rosy	Sq	Hall 1	Ensemble	Thru	Delay LR	FLT-Frq	off	off	off	off	off	FEG-Atk	InsL_prm10
71(E07)	Laizer	Sq	Hall 2	Chorus 2	Compressor	Tempo Delay 2	ELM-Lvl, FLT-Frq, ChoSend	off	off	off	off	off	ELM-Dly	InsL_prm10
72(E08)	2 Friends	Sq	Hall 2	Tempo Delay2	Phaser	Hall 2	ELM-Lvl, ChoSend, AEG-D1	off	off	off	off	off	InsS_prm10	FLT-Frq
73(E09)	Synfonic	Sq	Hall 2	Chorus 1	Thru	Tempo Cross Delay	InsL_prm10, ChoSend, FLT-Frq	off	off	off	off	off	InsL_prm10	RevSend
74(E10)	Hard road	Sq	Hall 1	Flanger 2	AMP Simulator	Delay LR	FEG-Atk, FLT-Frq	off	off	off	off	off	FEG-Atk, FLT-Frq	InsS_prm6
75(E11)	Quartz	Sq	Tunnel	Control Delay1	Flanger 3	Voice Cancelar	ELM-Lvl	off	off	off	off	off	InsL_prm11	InsL_prm12
76(E12)	Atom	Dr	White Room	Phaser	Touch Wah	Talking Modulator	ELFOSpd	off	off	off	off	off	InsL_prm1	RevSend
77(E13)	Chordal	Sq	Hall 1	Chorus 4	Thru	Delay LR	AEG-D2, FLT-Frq	off	off	off	off	off	PEG-Dpt	InsL_prm10, ChoSend
78(E14)	Orgmatic	Sq	Hall 2	Phaser	Compressor	Tempo Delay 2	InsL_prm10, ELM-Lvl, ELM-Lvl	off	off	off	off	off	FLT-Frq	RevSend
79(E15)	Ana Plus	Sq	Hall 1	Tempo Cross Delay	Compressor	Ensemble Detune	ELM-Lvl, InsL_prm10	off	off	off	off	off	ELM-Lvl	InsS_prm3, InsS_prm5
80(E16)	Frequencyz	Se	off	Tempo Cross Delay	Thru	Gate Reverb	ChoSend	off	off	off	off	off	FLT-Frq, FLT-Frq	InsL_prm10
81(F01)	Psycho	Se	Hall 1	Chorus 1	Thru	Harmonic Enhancer	ELFO-PM	off	FLT-Rez	off	off	off	RevSend	PCH-Crs
82(F02)	S - E	Se	Stage 2	Chorus 1	Flanger 3	Tempo Cross Delay	ELFO-PM	off	off	off	off	off	InsS_prm3	InsS_prm1
83(F03)	Voltage	Se	Hall 2	Flanger 2	AMP Simulator	Auto Synth	InsL_prm13	off	off	off	off	off	InsL_prm1	ChoSend, ELM-Lvl
84(F04)	Ectoplasm	Se	Hall 1	Tempo Cross Delay	Chorus 2	Symphonic	InsL_prm1	off	off	off	off	off	FLT-Frq	ELFO-AM
85(F05)	Millenium	Se	Hall 1	Flanger 1	Exciter	Hall 2	ELFO-PM, ELFO-FM	off	off	off	off	off	FLT-Frq	ELFO-PM
86(F06)	Noire	Se	Plate	Delay LR	Flanger 3	Ensemble Detune	ELFO-PM	off	off	off	off	off	InsS_prm3, InsS_prm2	PCH-Crs
87(F07)	Falling	Se	Hall 1	Chorus 1	Thru	Hall 1	ChoSend, Volume	off	off	off	off	off	FLT-Rez	ELM-Lvl, ELM-Lvl
88(F08)	Topnotched	Se	Hall 1	Tempo Delay2	Thru	Thru	ELFO-AM, Volume	off	off	off	off	off	ELFOSpd	FLT-Frq, FLT-Frq
89(F09)	Drumnotize	Se	Hall 1	Chorus 1	3band EQ	AMP Simulator	ELFO-PM	off	off	off	off	off	FLT-Frq	FLT-Rez
90(F10)	Creature	Se	Hall 1	Control Delay1	Thru	Pitch Change 2	FLT-Frq	off	off	off	off	off	ChoSend	RevSend
91(F11)	Develop	Se	Basement	Phaser	Phaser	Pitch Change 2	InsS_prm1	off	off	off	off	off	ELM-Lvl	RevSend
92(F12)	Twilight	Se	Canyon	Tempo Cross Delay	Celeste 4	Pitch Change 1	ELFO-AM, ELFOSpd	off	off	off	off	off	ELFOSpd, CLFOSpd	PCH-Crs
93(F13)	RisingHigh	Fx	Hall 1	Chorus 1	Thru	Thru	ELFO-AM	off	off	off	off	off	RevSend	ChoSend
94(F14)	90th Jimi	Fx	Hall 1	Flanger 2	AMP Simulator	Jump	ChoSend, FLT-Frq	off	off	off	off	off	FEG-Atk, FLT-Frq	InsS_prm6
95(F15)	Dew-drop	Fx	Stage 1	Tempo Delay1	Phaser	Pitch Change 2	InsS_prm1	off	off	off	off	off	ELM-Lvl	InsL_prm10, ChoSend
96(F16)	SpaceTrain	Fx	Hall 1	Ensemble	Phaser	Ensemble Detune	ELFOSpd	off	off	off	off	off	ChoSend	RevSend
97(G01)	Brown Eyes	Fx	Plate	Symphonic	Exciter	Auto Synth	InsL_prm10, FEG-Atk	off	off	off	off	off	InsL_prm12	InsL_prm3
98(G02)	Glacier	Fx	Stage 1	Tempo Cross Delay	Celeste 4	Harmonic Enhancer	InsS_prm1	off	off	off	off	off	ELM-Lvl	ChoSend
99(G03)	Sahara	Fx	Hall 1	Chorus 1	Flanger 1	Hall 1	FLT-Frq	off	off	off	off	off	AEG-Atk	ChoSend
100(G04)	Sunnydaze	Fx	Stage 1	Tempo Cross Delay	Chorus 1	Chorus 1	ELFO-AM, ELM-Lvl	off	off	off	off	off	InsL_prm10, InsS_prm10	ELFOSpd
101(G05)	Starlight	Fx	Hall 1	Chorus 1	Thru	Pitch Change 2	ELM-Lvl	off	off	off	off	off	FLT-Frq	ChoSend
102(G06)	Roxy	Fx	Hall 2	Ensemble	Chorus 4	Thru	CLFO-D1, CLFO-D2, ELM-Lvl	off	off	off	off	off	FEG-Dpt	CLFOSpd
103(G07)	Bel Air	Fx	Hall 2	Chorus 4	Exciter	Flanger 3	InsS_prm1, FLT-Rez, FLT-Frq	off	off	off	off	off	InsL_prm10	ChoSend
104(G08)	Answers	Fx	Hall 1	Chorus 1	Thru	Delay LR	Volume	off	off	off	off	off	ELM-Dly	RevSend
105(G09)	Bassline	Ba	Hall 1	Flanger 2	Distortion	Delay LCR	ChoSend, ELM-Lvl	off	off	off	off	off	FEG-Atk	InsS_prm10, InsL_prm10
106(G10)	Boom Bass	Ba	Room 3	Symphonic	Compressor	Voice Cancelar	PEG-Atk	off	off	off	off	off	ELFO-PM	ELFOSpd
107(G11)	Drone	Ba	Hall 2	Chorus 2	Compressor	Tempo Delay 2	FLT-Frq, CLFOSpd, FLT-Rez	off	off	off	off	off	InsL_prm10, ChoSend	RevSend
108(G12)	Sweezy	Ba	Hall 2	Chorus 4	Thru	Delay LR	FLT-Frq, ChoSend	off	off	off	off	off	FEG-Atk	InsL_prm10, ChoSend
109(G13)	Super DX	Ba	Room 1	Chorus 1	Exciter	Ensemble Detune	ELFO-PM	off	off	off	off	off	FLT-Frq	FLT-Rez
110(G14)	GangstaM	Ba	Room 1	Symphonic	Compressor	Tempo Cross Delay	FLT-Frq, RevSend	off	off	off	off	off	ChoSend, Volume	RevSend
111(G15)	FM Perko	Ba	Room 1	Chorus 2	Compressor	V-Flanger	ChoSend, ELM-Lvl, Volume	off	off	off	off	off	RevSend	FLT-Frq
112(G16)	DX100	Ba	Room 3	Chorus 1	Thru	Thru	FLT-Frq	off	off	off	off	off	ELFO-FM	RevSend
113(H01)	BriteGrand	Pf	Hall 1	Chorus 1	3band EQ	Flanger 3	InsL_prm10	off	off	off	off	off	ChoSend	RevSend
114(H02)	Slamming	Pf	Room 3	Tempo Delay2	Compressor	Voice Cancelar	AEG-D1	off	off	off	off	off	InsL_prm11	InsL_prm12
115(H03)	Danzze	Pf	Room 1	Control Delay1	Overdrive	Thru	ChoSend, RevSend	off	off	off	off	off	ELM-Pan	FLT-Frq
116(H04)	House	Pf	Room 2	Control Delay2	Compressor	Ambience	RevSend	off	off	off	off	off	InsL_prm10	ChoSend, FLT-Frq
117(H05)	M25	Pf	Hall 1	Tempo Delay1	Exciter	Pitch Change 1	InsL_prm10	off	off	off	off	off	PCH-Fin	ChoSend
118(H06)	AcidFly	Pf	Stage 1	Delay LR	AMP Simulator	Digital Scratch	ChoSend, RevSend	off	off	off	off	off	InsL_prm5	InsL_prm11
119(H07)	Nite Roadz	Pf	Hall 2	Chorus 1	Compressor	Celeste 4	InsL_prm1, InsL_prm2	off	off	off	off	off	InsL_prm10	RevSend
120(H08)	GS Brassy	Sc	Hall 1	Chorus 1	Chorus 1	Thru	ELFO-PM	off	off	off	off	off	FEG-D2, FEG-D1, AEG-D2	RevSend
121(H09)	Grand Pad	Co	Hall 1	Chorus 1	3band EQ	Tempo Cross Delay	AEG-Atk	off	off	off	off	off	FLT-Frq	InsL_prm10
122(H10)	Ibiza	Co	Hall 1	Tempo Delay1	Compressor	Celeste 4	FLT-Frq	off	off	off	off	off	RevSend	ChoSend
123(H11)	Melpiano	Co	Plate	Chorus 1	Thru	Symphonic	ELM-Lvl	off	off	off	off	off	ELM-Lvl	RevSend
124(H12)	HonkyTonk	Pf	Room 1	Chorus 1	Thru	Pitch Change 1	ChoSend	off	off	off	off	off	FLT-Frq	RevSend
125(H13)	For Ballad	Pf	Hall 1	Delay LR	Thru	Chorus 4	ELM-Lvl	off	off	off	off	off	ChoSend	RevSend
126(H14)	ShineHarmo	Pf	Hall 1	Chorus 1	3band EQ	Chorus 5	ChoSend, Volume	off	off	off	off	off	PCH-Crs	RevSend
127(H15)	TripleDark	Pf	Hall 1	Chorus 1	3band EQ	Thru	ChoSend	off	off	off	off	off	FLT-Frq	RevSend
128(H16)	StageBrite	Pf	Hall 1	Chorus 1	Thru	Harmonic Enhancer	ChoSend	off	off	off	off	off	FLT-Frq	RevSend

Internal (MSB=63, LSB=8)

No.	Voice Name	Category	Reverb Type	Chorus Type	Insertion1 Type	Insertion2 Type	MW	PB	AT	FC	BC	FS	Kn1	Kn2
1(A01)	Hybrid	Pf	Hall 1	Chorus 1	Thru	Thru	ChoSend	off	off	off	off	off	FLT-Frq, FLT-Rez	RevSend
2(A02)	DarkGrand2	Pf	Room 2	Chorus 1	3band EQ	Thru	ChoSend	off	off	off	off	off	FLT-Frq	RevSend
3(A03)	BrtStereo	Pf	Hall 1	Celeste 1	3band EQ	Phaser 2	InsL prm10	off	off	off	off	off	ChoSend	RevSend
4(A04)	HonkyTnk2	Pf	Room 3	Chorus 1	Thru	Thru	ChoSend	off	off	off	off	off	FLT-Frq	RevSend
5(A05)	Differenc2	Pf	Hall 1	Chorus 1	3band EQ	Harmonic Enhancer	InsL prm3	off	off	off	off	off	ChoSend	RevSend
6(A06)	Piano/Ep2	Pf	Hall 1	Chorus 1	Chorus 1	Thru	FLT-Frq, ELM-Lvl	off	off	off	off	off	ELM-Lvl, ELM-Lvl	InsS prm10
7(A07)	Pno/Oo/Str	Co	Hall 1	Chorus 1	Chorus 2	Thru	ELM-Lvl	off	off	off	off	off	ELM-Lvl	ChoSend
8(A08)	Grand Pad2	Co	Hall 1	Delay LR	Chorus 1	Thru	ELM-Lvl	off	off	off	off	off	FLT-Frq	ChoSend
9(A09)	Phase CP	Pf	Room 1	Chorus 1	Thru	Phaser 2	FLT-Frq	off	off	off	off	off	InsL prm10, InsL prm4, InsL prm2	RevSend
10(A10)	CP Layer	Pf	Room 2	Ensemble	Thru	Thru	RevSend	off	off	off	off	off	FLT-Frq	ChoSend
11(A11)	Wurlii Amp	Pf	Room 1	Celeste 1	Overdrive	Tremolo	InsL prm2, Volume	off	off	off	off	off	FLT-Frq	InsS prm1, RevSend
12(A12)	SunShine	Pf	Room 2	Chorus 1	Auto Pan	Compressor	InsS prm1	off	off	off	off	off	InsS prm2	RevSend
13(A13)	Phaser EP	Pf	Hall 2	Flanger 1	Flanger 1	Phaser 1	ELFO-PM	off	off	off	off	off	InsL prm4, InsL prm1	RevSend
14(A14)	RB Roadz	Pf	Hall 1	Chorus 1	Compressor	Celeste 3	InsL prm1	off	off	off	off	off	InsS prm4, InsS prm3	RevSend
15(A15)	BasicRoad2	Pf	Hall 1	Chorus 1	3band EQ	Auto Pan	InsL prm1	off	off	off	off	off	InsL prm2	RevSend, ChoSend
16(A16)	Early70Rhd	Pf	Stage 1	Chorus 1	Tremolo	V-Distortion	InsS prm2	off	off	off	off	off	AEG-D1	RevSend
17(B01)	Doogie	Pf	Hall 1	Chorus 1	Thru	Thru	CLFO-D1	off	off	off	off	off	FLT-Frq	ChoSend, RevSend
18(B02)	RT Roadz	Pf	Stage 1	Chorus 1	Auto Pan	Phaser 1	InsS prm1, InsL prm1	off	off	off	off	off	InsS prm2	RevSend
19(B03)	Dyno Pad	Co	Hall 1	Chorus 1	Chorus 1	Thru	ELM-Lvl	off	off	off	off	off	FLT-Frq	ChoSend, RevSend
20(B04)	Roadz Pad	Co	Stage 2	Chorus 1	Auto Pan	Chorus 3	InsS prm2	off	off	off	off	off	FLT-Frq	ChoSend, Volume
21(B05)	NiteBallad	Pf	Hall 2	Chorus 1	Compressor	Celeste 4	InsL prm1, InsL prm2	off	off	off	off	off	InsL prm10	RevSend
22(B06)	DXTinyVel	Pf	Hall 1	Symphonic	Celeste 4	Harmonic Enhancer	ELFO-AM	off	off	off	off	off	InsL prm3	RevSend
23(B07)	DX Hard	Pf	Hall 1	Chorus 1	Exciter	Symphonic	ELFO-AM	off	off	off	off	off	InsS prm3	RevSend
24(B08)	Superstit	Pf	Room 3	Chorus 2	AMP Simulator	Phaser 2	InsL prm10	off	off	off	off	off	AEG-D1, AEG-D2	ChoSend
25(B09)	Puls Clav	Sc	Hall 1	Phaser	Thru	Thru	ELFO-PM	off	off	off	off	off	FLT-Rez	AEG-D1, AEG-D2
26(B10)	Handbel	Cp	Hall 1	Chorus 1	Thru	Thru	ELFO-AM	off	off	off	off	off	FLT-Frq	ChoSend, RevSend
27(B11)	Estrn Bel1	Cp	Hall 1	Celeste 1	Chorus 1	Thru	ChoSend	off	off	off	off	off	FLT-Frq	PCH-Crs
28(B12)	Tiny bell	Cp	Hall 1	Chorus 1	Chorus 1	Thru	ChoSend	off	off	off	off	off	FLT-Frq	AEG-Atk
29(B13)	Argent	Or	Room 1	Chorus 1	Overdrive	Rotary Speaker 1	InsL prm1	off	off	off	off	off	InsL prm9	InsL prm1
30(B14)	Como Va	Or	Room 1	Chorus 1	Overdrive	Rotary Speaker 1	InsL prm1, InsL prm2	off	off	off	off	off	InsL prm9	InsL prm1
31(B15)	Blackpool	Or	White Room	Chorus 1	Thru	2Way Rotary Speaker	InsL prm1	off	InsL prm1	off	off	off	ELM-Lvl	RevSend
32(B16)	Tonewheels	Or	Room 1	Chorus 5	Thru	Thru	ELFO-PM, ELFO-AM, ELFO-Spd	off	off	off	off	off	ELM-Lvl	ChoSend
33(C01)	BowNL	Or	Room 1	Chorus 1	Thru	Thru	RevSend, ELFO-PM	off	off	off	off	off	FLT-Frq	FLT-Rez
34(C02)	BassWalk	Or	Room 1	Chorus 1	Thru	Rotary Speaker 1	InsL prm1	off	off	off	off	off	InsL prm9	InsL prm1
35(C03)	WhiteShade	Or	Hall 1	Chorus 1	3band EQ	Amp Simu + 2Way Rotary Speaker	InsL prm1	off	off	off	off	off	FLT-Frq	RevSend
36(C04)	Draws	Or	Room 1	Chorus 1	Thru	2Way Rotary Speaker 3	InsL prm16	off	InsL prm2, InsL prm3	off	off	off	InsL prm4	InsL prm5, InsL prm6
37(C05)	PercMellow	Or	Room 1	Chorus 1	Thru	Rotary Speaker 1	InsL prm1	off	off	off	off	off	InsL prm9	InsL prm1
38(C06)	RhoBassFiz	Or	Room 1	Chorus 1	AMP Simulator	Rotary Speaker 1	InsL prm1, InsL prm2	off	off	off	off	off	RevSend	InsL prm1
39(C07)	Knob Drive	Or	Room 1	Chorus 1	AMP Simulator	Rotary Speaker 1	InsL prm1	off	off	off	off	off	InsS prm1	InsL prm1
40(C08)	E Bird	Or	Hall 1	Chorus 4	Thru	Rotary Speaker 1	InsL prm1	off	off	off	off	off	RevSend	ELM-Lvl
41(C09)	16-**-4	Or	Hall 1	Chorus 5	Thru	2Way Rotary Speaker	InsL prm1, InsL prm9	off	off	off	off	off	RevSend	ChoSend
42(C10)	16-5-4-1-1	Or	Hall 1	Chorus 5	Thru	Rotary Speaker 1	InsL prm1, InsL prm9	off	off	off	off	off	RevSend	ChoSend
43(C11)	Mw Church	Or	Hall 2	Celeste 1	Thru	Thru	ChoSend, ELM-Lvl	off	off	off	off	off	FLT-Frq	RevSend
44(C12)	Big Church	Or	Hall 2	Celeste 1	Thru	Thru	FLT-Frq	off	off	off	off	off	ChoSend	RevSend
45(C13)	Hawks	Gt	Hall 1	Chorus 1	Exciter	Harmonic Enhancer	ELFO-PM	off	off	off	off	off	FEG-D1	ChoSend
46(C14)	GoldGuitar	Gt	Room 3	Chorus 4	Thru	2Band EQ	ELFO-PM	off	off	off	off	off	RevSend	ChoSend
47(C15)	ElAc Mix	Gt	Hall 1	Delay LR	Chorus 1	Comp Distortion	ELFO-PM	off	off	off	off	off	ELM-Lvl, ELM-Lvl	ChoSend, RevSend
48(C16)	VintStrat	Gt	White Room	Delay LR	AMP Simulator	Tremolo	InsL prm1	off	off	off	off	off	ChoSend	RevSend
49(D01)	StratChor3	Gt	Hall 1	Chorus 4	3band EQ	AMP Simulator	FLT-Frq	off	off	off	off	off	ChoSend	RevSend
50(D02)	VeloGuitar	Gt	Room 2	Chorus 4	Thru	AMP Simulator	ELFO-PM, ELFO-FM, ELFO-Spd	off	off	off	off	off	InsL prm10	ChoSend, Volume
51(D03)	Jazz Man	Gt	Stage 2	Chorus 5	Thru	Thru	ELFO-PM	off	off	off	off	off	RevSend	ChoSend
52(D04)	FMJazzGtr	Gt	Room 3	Chorus 4	Thru	Ambience	ELFO-PM	off	off	off	off	off	FLT-Frq	RevSend
53(D05)	Cry	Gt	Hall 1	Chorus 1	Auto Wah	Comp+Dist+Delay	ELFO-PM	InsL prm14	off	off	off	off	InsS prm1	ChoSend, Volume
54(D06)	P.F. Echo	Gt	Room 3	Delay LR	3band EQ	2Way Rotary Speaker	ELFO-PM	off	off	off	off	off	ChoSend	InsL prm14, Volume
55(D07)	Birdy	Gt	Room 3	Phaser	3band EQ	V-Distortion	ELFO-PM	off	off	off	off	off	InsL prm1, Volume	InsL prm11
56(D08)	Velo Chunk	Gt	Room 3	off	3band EQ	V-Distortion	ELFO-PM	off	off	off	off	off	InsL prm4, InsL prm1	InsL prm11
57(D09)	VirtualDis	Gt	Hall 1	Delay LR	AMP Simulator	Comp Distortion	CLFO-D1	off	off	off	off	off	InsS prm6	ChoSend
58(D10)	100 Watts	Gt	Room 3	Phaser	3band EQ	V-Distortion	ELFO-PM	off	off	off	off	off	InsL prm11	InsL prm1
59(D11)	Acst Vox	Co	Hall 1	Chorus 1	Thru	Delay LCR	ELM-Lvl	off	off	off	off	off	FLT-Frq, FLT-Rez	ChoSend
60(D12)	Prec Bass	Ba	Hall 1	Chorus 1	AMP Simulator	3Band EQ	CLFO-D1	off	off	off	off	off	ChoSend	InsL prm1
61(D13)	Fing Sting	Ba	Hall 1	Chorus 1	Exciter	3Band EQ	CLFO-D1	off	off	off	off	off	ChoSend	InsL prm1
62(D14)	FretlesAmp	Ba	Hall 1	Chorus 1	3band EQ	AMP Simulator	ELFO-PM	off	off	off	off	off	FLT-Frq	ChoSend
63(D15)	Slap&Pull	Ba	Room 1	Chorus 1	Thru	Thru	ELFO-PM	off	off	off	off	off	FLT-Frq, FLT-Frq	ChoSend
64(D16)	Bs+Cmbal	Co	Hall 1	Chorus 1	Thru	Thru	ELFO-PM	off	off	off	off	off	PCH-Crs	ELM-Lvl

No.	Voice Name	Category	Reverb Type	Chorus Type	Insertion1 Type	Insertion2 Type	MW	PB	AT	FC	BC	FS	Kn1	Kn2
65(E01)	Big Sction	St	Hall 1	Chorus 1	3band EQ	Thru	ChoSend, Volume	AEG-Rel	off	off	off	off	FLT-Frq	AEG-Atk
66(E02)	EnsembMlx	St	Hall 1	Ensemble	Thru	Thru	ChoSend, ELM-Lvl	off	off	off	off	off	FLT-Frq	AEG-Atk, AEG-Rel
67(E03)	Agitato	St	Hall 1	Chorus 1	3band EQ	Thru	ChoSend, Volume	off	off	off	off	off	FLT-Frq	ELFO-AM, ELFO-FM, CLFOSpd
68(E04)	Analog Mix	St	Hall 1	Ensemble	Thru	Thru	ChoSend, Volume	off	off	off	off	off	FLT-Frq	AEG-Atk, AEG-Rel
69(E05)	Violin	St	Hall 1	Chorus 1	Thru	Thru	FLT-Frq	off	off	off	off	off	AEG-Rel, AEG-Atk	ChoSend, RevSend, Volume
70(E06)	Big Pizz	St	Hall 1	Chorus 3	Thru	Thru	ChoSend	off	off	off	off	off	FLT-Frq	ELM-Dly
71(E07)	HarpStrum	St	Room 3	Celeste 2	Thru	Thru	ELFO-PM	off	off	off	off	off	RevSend	ChoSend
72(E08)	Wood Winds	Co	Hall 1	Ensemble	Thru	Thru	CLFO-D1, CLFO-D2, ELFO-PM, ELFO-FM	off	off	off	off	off	FLT-Frq	ChoSend
73(E09)	Pan Attack	Pi	Hall 1	Chorus 1	Thru	Thru	ELFO-AM, ELFO-FM	off	off	off	off	off	FLT-Frq, FLT-Rez	AEG-Atk
74(E10)	AnaString	St	Hall 2	Ensemble	Chorus 1	Cross Delay	CLFO-D1, FLT-Frq	off	off	off	off	off	InsS prm10	ChoSend
75(E11)	AnaString2	St	Hall 2	Symphonic	Chorus 3	Harmonic Enhancer	PCH-Fin	off	off	off	off	off	InsS prm3, InsS prm10, InsS prm6	InsL prm2
76(E12)	Tron	St	Hall 1	Phaser	3band EQ	Thru	ELM-Lvl	off	off	off	off	off	RevSend, ChoSend	FLT-Frq
77(E13)	Brs/Strgs	Br	Hall 1	Chorus 1	Thru	Thru	ELM-Lvl	off	off	off	off	off	ELM-Lvl	PCH-Crs
78(E14)	MediumBrs2	Br	Hall 1	Chorus 1	3band EQ	Thru	ChoSend	off	off	off	off	off	FLT-Frq	RevSend
79(E15)	SoftBrass	Br	Hall 2	Chorus 1	Thru	Cross Delay	ChoSend	off	off	off	off	off	FLT-Frq	InsL prm10, RevSend
80(E16)	HybrdBrs	Br	Hall 1	Chorus 1	Thru	Delay LCR	ELFO-PM, ELFO-FM	off	off	off	off	off	FLT-Frq, FLT-Rez	RevSend
81(F01)	Class Sect	Br	Hall 1	Chorus 3	Chorus 3	Thru	InsS prm10	off	off	off	off	off	FLT-Frq	ELM-Lvl
82(F02)	Sfz Brass	Br	Stage 2	Chorus 1	Thru	Thru	ELFO-PM, ELFO-PM	off	off	off	off	off	FLT-Frq	FEG-D2, FEG-D1
83(F03)	Pop Brass	Br	Hall 1	Chorus 1	Thru	Thru	ELFO-FM, ELFO-PM	off	off	off	off	off	FLT-Frq	ChoSend, Volume
84(F04)	Classical	Br	Hall 1	Chorus 1	Thru	Thru	ELFO-FM, ELFO-PM	off	off	off	off	off	FLT-Frq	ChoSend, Volume
85(F05)	Fr Horns	Br	Hall 1	Chorus 1	Thru	Delay LCR	ELFO-PM, ELFO-AM	off	off	off	off	off	RevSend	ChoSend
86(F06)	Flugel	Br	Hall 1	Ensemble	3band EQ	Thru	CLFO-D1, CLFO-D2	off	off	off	off	off	FLT-Frq	RevSend
87(F07)	Brth Tenor	Rd	Hall 2	Chorus 1	3band EQ	Thru	ELFO-PM, ELFO-AM	off	off	off	off	off	FLT-Frq	ChoSend, RevSend
88(F08)	Velo Growl	Rd	Hall 1	Delay LR	Thru	Thru	ELFO-PM, CLFO-D1	off	off	off	off	off	ChoSend	RevSend
89(F09)	NuSopmo	Rd	Hall 1	Chorus 1	3band EQ	Thru	ELFO-PM, ELFO-AM	off	off	off	off	off	FLT-Frq	ChoSend
90(F10)	J Stabs	Br	Hall 1	Delay LR	Thru	Ensemble Detune	ELFO-PM	off	off	off	off	off	RevSend	ChoSend
91(F11)	Oberhorns	Br	Hall 1	Chorus 4	Thru	Cross Delay	CLFO-D1	off	off	off	off	off	FEG-Atk	ChoSend
92(F12)	Africa	Br	Hall 1	Delay LR	Thru	Thru	ELFO-PM	off	off	off	off	off	FLT-Frq, FLT-Rez	PEG-Dpt, AEG-Atk
93(F13)	NuTekBrss	Br	Hall 1	Chorus 4	Distortion	Cross Delay	ChoSend, ELM-Lvl	off	ELFO-PM	off	off	off	PCH-Fin	ChoSend
94(F14)	CS80Brass	Br	Hall 1	Delay LR	Thru	Thru	ELFO-PM	off	off	off	off	off	FLT-Frq, FLT-Rez	RevSend, ChoSend
95(F15)	Fat Brazz	Br	Hall 1	Chorus 4	Thru	Cross Delay	CLFO-D1	off	off	off	off	off	FEG-Atk	ChoSend
96(F16)	EgoSix	Br	Hall 2	Chorus 2	Compressor	Early Ref 1	ChoSend, RevSend, FLT-Frq	off	off	off	off	off	InsL prm10	ChoSend
97(G01)	Ambi Star	Fx	Hall 2	Ensemble	Flanger 3	Cross Delay	FLT-Frq, FLT-Rez, ChoSend	off	off	off	off	off	InsS prm1	InsS prm10
98(G02)	Champ	Fx	Hall 2	Delay LR	Chorus 1	Ensemble Detune	FLT-Rez, ELM-Lvl	off	off	off	off	off	FEG-Atk	InsL prm10
99(G03)	Rndm Gruv	Fx	Hall 2	Ensemble	Chorus 4	Cross Delay	CLFO-D1, ChoSend	off	off	off	off	off	ChoSend, ELM-Lvl	CLFO-D2
100(G04)	Generation	Sq	Hall 2	Tempo Cross Delay	Exciter	Ensemble Detune	FLT-Rez, FLT-Frq	off	off	off	off	off	FLT-Rez	InsS prm1
101(G05)	Molecule	Fx	Hall 1	Tempo Cross Delay	Phaser	Ensemble Detune	ELFO-FM, InsS prm1, InsS prm2	off	off	off	off	off	ELFOspd	ELM-Lvl, ELM-Lvl
102(G06)	Teardrops	Fx	Room 3	Control Delay1	Phaser	Compressor	InsS prm4, AEG-Atk	off	off	off	off	off	InsS prm10	InsS prm1
103(G07)	Hades	Fx	Hall 1	Delay LR	Thru	Celeste 2	ELFO-PM	off	off	off	off	off	RevSend	RevSend
104(G08)	Voyager	Fx	Canyon	Tempo Cross Delay	Phaser	Flanger 3	ELFO-FM	off	off	off	off	off	InsL prm1, InsS prm1, ChoSend	ELFOspd, FLT-Frq
105(G09)	Waterfowl	Fx	Stage 1	Tempo Cross Delay	Phaser	Harmonic Enhancer	ELFOspd	off	off	off	off	off	InsS prm4	RevSend
106(G10)	Mayflower	Fx	Canyon	Tempo Cross Delay	Flanger 3	Compressor	ELFO-AM, PCH-Fin	off	off	off	off	off	ELFOspd, ELFO-PM	InsS prm1
107(G11)	Cronen	Pd	Plate	off	Chorus 3	Rotary Speaker 1	InsL prm1, InsL prm9	off	off	off	off	off	ELM-Lvl, ELM-Lvl	InsS prm3
108(G12)	Padness	Pd	Canyon	Chorus 2	Touch Wah	Pitch Change 1	CLFO-D2	off	off	off	off	off	InsS prm8	InsL prm10
109(G13)	Luminosity	Pd	Hall 1	Chorus 1	Flanger 2	Delay LCR	ELFO-AM	off	off	off	off	off	RevSend	ChoSend
110(G14)	Expanse	Pd	Hall 1	Chorus 1	Thru	Echo	ELFO-PM	off	off	off	off	off	ELM-Lvl	ChoSend
111(G15)	Vox 5ths	Pd	Hall 2	Symphonic	Thru	Delay LCR	PCH-Crs, PCH-Crs	off	off	off	off	off	FLT-Frq, FLT-Rez	ChoSend
112(G16)	Cleansing	Pd	Hall 1	Symphonic	Chorus 1	Delay LCR	CLFO-D1	off	off	off	off	off	ChoSend	FLT-Frq, RevSend
113(H01)	4000 Volts	Se	Hall 1	Chorus 1	Chorus 3	Flanger 1	FLT-Frq	off	InsL prm3	off	off	off	PEG-Dpt	FEG-Atk
114(H02)	Rainstorm	Se	Hall 1	Chorus 3	Thru	Thru	FLT-Frq	off	off	off	off	off	PCH-Crs	ELM-Lvl
115(H03)	RadioNoiz	Se	Hall 1	Chorus 3	3band EQ	LO-FI	ELFOspd	InsL prm2	off	off	off	off	FLT-Frq	InsL prm1
116(H04)	Turntablz	Se	Hall 1	Chorus 1	Thru	LO-FI	ELFO-PM, ELFO-FM	off	off	off	off	off	ChoSend	PCH-Crs
117(H05)	Manufactur	Se	Room 1	Ensemble	Phaser	Delay LR	ELFO-PM	off	off	off	off	off	ELM-Pan, ELM-Pan	RevSend
118(H06)	Zap	Se	Hall 1	Control Delay1	3band EQ	Thru	PCH-Crs	AEG-D1	off	off	off	off	PEG-Hld	ChoSend, RevSend
119(H07)	Helicopt	Se	Hall 1	Phaser	Thru	Auto Pan	FLT-Rez, FLT-Frq, FLT-Frq	ELFOspd	off	off	off	off	ELM-Lvl	RevSend
120(H08)	Siens	Se	Hall 1	Chorus 1	Thru	Thru	RevSend	off	off	off	off	off	ELFOspd	ChoSend
121(H09)	Bubbles	Se	Hall 1	Chorus 3	3band EQ	LO-FI	ELFOspd	InsL prm2	off	off	off	off	FLT-Frq	InsL prm1
122(H10)	Beatniks	Pc	Hall 1	Tempo Delay1	Thru	Thru	ChoSend	off	off	off	off	off	FLT-Frq, FEG-Dpt	ELM-Lvl
123(H11)	Cybr Whip	Pc	Stage 2	Chorus 1	Thru	V-Flanger	InsL prm2	off	off	off	off	off	FLT-Frq	AEG-Atk
124(H12)	Voiccy	En	Hall 2	Chorus 1	Compressor	Hall 2	ELM-Lvl, ELM-Lvl, FLT-Frq	off	off	off	off	off	ELM-Pan	RevSend
125(H13)	FormantStg	En	Hall 1	Chorus 1	Chorus 2	Talking Modulator	InsL prm1	off	off	off	off	off	FLT-Frq	FLT-Rez
126(H14)	Airy	Vo	Hall 1	Control Delay2	Thru	Thru	ELFO-PM	off	off	off	off	off	PCH-Crs	AEG-Atk, AEG-Rel
127(H15)	Chandelier	Vo	Hall 2	Ensemble	Exciter	Chorus 4	InsS prm1, ELM-Lvl, FLT-Frq	off	off	off	off	off	InsS prm1	FLT-Frq
128(H16)	Choir Atk	Vo	Hall 1	Chorus 1	Exciter	3Band EQ	ELFO-PM, ELFO-AM	off	off	off	off	off	FLT-Frq	FLT-Rez

Quick Access Voice List

Bank	Category	Program Key	Memory	Voice Program Number	Voice Name
A	A.PIANO	1	PRE1	1	StereoGrnd
		2	PRE1	2	StereoGnd2
		3	PRE1	3	CF Grand M
		4	PRE1	4	Dark Grand
		5	PRE1	5	Difference
		6	PRE2	114	Slamming
		7	PRE1	9	CP2000
		8	PRE2	124	For Ballad
		9	PRE1	7	Piano/Strg
		10	PRE1	8	Piano/Oohs
		11	PRE1	6	Piano/Ep
		12	PRE1	10	Piano/DX
		13	INT	1	Hybrid
		14	INT	2	DarkGrand2
		15	INT	3	BrtStereo
		16	INT	4	HonkyTrnk2
B	E.PIANO	1	PRE1	17	Vic'sRoadz
		2	PRE1	18	ErlyFusion
		3	PRE1	16	19 Roadz
		4	PRE1	20	VintgCond
		5	PRE1	11	Wurlitrm
		6	PRE1	13	DF EP IV
		7	PRE1	14	Herb Roadz
		8	PRE1	21	DXAtacky
		9	PRE1	24	Ice Piano
		10	PRE1	26	Bel Roadz
		11	PRE1	31	Clav
		12	PRE1	30	Harpsicode
		13	INT	17	Doogie
		14	INT	18	RT Roadz
		15	INT	19	Dyno Pad
		16	INT	20	Roadz Pad
C	ORGAN	1	PRE1	33	Perc Org
		2	PRE1	34	Cool
		3	PRE1	35	ClickOrgan
		4	PRE1	36	Jazz
		5	PRE1	37	Soft Rock
		6	PRE1	38	Tube
		7	PRE1	39	Contnental
		8	PRE1	40	Swish
		9	PRE1	44	Sunday
		10	PRE1	45	Pipes
		11	PRE1	41	4 Bars
		12	PRE1	42	Full
		13	INT	33	BowNL
		14	INT	34	BassWalk
		15	INT	35	WhiteShade
		16	INT	36	Draws
D	GTR/BASS	1	PRE1	46	New Nylon
		2	PRE1	48	Melo Trmlo
		3	PRE1	54	DirtyTwn
		4	PRE1	49	Strat Chor
		5	PRE1	56	BOODOO MAN
		6	PRE1	52	Acoustic
		7	PRE1	58	Funk It!!
		8	PRE1	59	Upright
		9	PRE1	60	Finger
		10	PRE1	61	PickBass
		11	PRE1	62	Fretless
		12	PRE1	63	Slap
		13	INT	49	StratChor3
		14	INT	50	3VeloGuitar
		15	INT	51	Jazz Man
		16	INT	52	FMJazzGtr
E	STRINGS	1	PRE1	65	Background
		2	PRE1	66	Big String
		3	PRE1	67	Cello Big
		4	PRE1	68	Chamberz
		5	PRE1	69	SmallSect
		6	PRE1	70	CelloSmall
		7	PRE1	76	Wind Orch
		8	PRE1	77	SynthStrgs
		9	PRE1	78	ObiStrings
		10	PRE2	57	Big Syn
		11	PRE1	71	Pizz
		12	PRE1	72	Harp
		13	INT	65	Big Sction
		14	INT	66	EnsemblMix
		15	INT	67	Agitato
		16	INT	68	Analog Mix

Bank	Category	Program Key	Memory	Voice Program Number	Voice Name
F	BRASS	1	PRE1	79	Fanfare
		2	PRE1	80	MediumBrss
		3	PRE1	81	Two Brass
		4	PRE1	82	Brass&Sax
		5	PRE1	85	Trumpet
		6	PRE1	86	Mute Trpt
		7	PRE1	87	Tenor Sax
		8	PRE1	88	Alto Sax
		9	PRE1	90	Soprano
		10	PRE1	92	PowerSynth
		11	PRE1	94	M Brass
		12	PRE1	95	Moon AT
		13	INT	81	Class Sect
		14	INT	82	Stz Brass
		15	INT	83	Pop Brass
		16	INT	84	Classical
G	SYNTH	1	PRE1	101	Soft Pad
		2	PRE2	50	5thBreath
		3	PRE2	63	Soft Dream
		4	PRE2	58	Berlin
		5	PRE1	111	Liquito
		6	PRE2	22	Zap Comp
		7	PRE2	36	Lucky
		8	PRE2	37	Sneaky
		9	PRE2	40	Rap Lead3
		10	PRE2	5	Mini 1
		11	PRE2	3	Velo
		12	PRE2	109	Super DX
		13	INT	97	Ambi Star
		14	INT	98	Champ
		15	INT	99	Rndm Gruv
		16	INT	100	Generation
H	OTHER	1	PRE1	113	Vibes
		2	PRE1	114	Marimba
		3	PRE1	117	Glocken
		4	PRE1	97	Ooh Choir
		5	PRE1	98	Ahh Choir
		6	PRE2	101	Starlight
		7	PRE2	93	RisingHigh
		8	PRE2	67	Kickwheel
		9	PRE2	70	Rosy
		10	PRE2	73	Synfonic
		11	PRE2	74	Hard road
		12	PRE2	76	Atom
		13	INT	113	4000 Volts
		14	INT	114	RainStorm
		15	INT	115	RadioNoiz
		16	INT	116	Turntablz

Drum Voice List

Preset (MSB=63, LSB=32)

1 Rock Kit

Note	ElmAsgn	Wave No.	Wave Name
C 0	on	378	Dr BdVar5
C#0	on	389	Dr SdPcBH
D 0	on	391	Dr SdWdH
D#0	on	392	Dr SdVar1
E 0	on	376	Dr BdVar3
F 0	on	405	Dr SdRoll
F#0	on	382	Dr SdBldH
G 0	on	400	Dr SdDry
G#0	on	408	Dr Stick
A 0	on	377	Dr BdVar4
A#0	on	389	Dr SdPcBH
B 0	on	374	Dr BdVar1
C 1	on	371	Dr SdPop
C#1	on	407	Dr C.Rim2
D 1	on	387	Dr SdHvy
D#1	on	358	Pc Clap
E 1	on	380	Dr SdGM
F 1	on	418	Dr Tom2L
F#1	on	423	Dr HHCl5
G 1	on	418	Dr Tom2L
G#1	on	425	Dr HHPdl2
A 1	on	418	Dr Tom2L
A#1	on	426	Dr HHOpn
B 1	on	417	Dr Tom2H
C 2	on	417	Dr Tom2H
C#2	on	433	Dr Crash
D 2	on	417	Dr Tom2H
D#2	on	429	Dr Ride
E 2	on	435	Dr China
F 2	on	431	Dr Cup
F#2	on	354	Pc Tmborn
G 2	on	434	Dr Crash2
G#2	on	340	Pc Cowbel
A 2	on	434	Dr Crash2
A#2	on	356	Pc VbSlp
B 2	on	432	Dr Cup2
C 3	on	336	Pc BongoH
C#3	on	335	Pc BongoL
D 3	on	339	Pc CngSlp
D#3	on	338	Pc CongaH
E 3	on	337	Pc CongaL
F 3	on	345	Pc TmbIsH
F#3	on	344	Pc TmbIsL
G 3	on	341	Pc AgogoL
G#3	on	341	Pc AgogoL
A 3	on	349	Pc Cabasa
A#3	on	352	Pc Maracs
B 3	on	435	Dr China
C 4	on	434	Dr Crash2
C#4	on	355	Pc TrngL
D 4	on	101	Cp FngCym
D#4	on	350	Pc Claves
E 4	on	348	Pc Wdblck
F 4	on	348	Pc Wdblck
F#4	on	113	Cp Timpni
G 4	on	113	Cp Timpni
G#4	on	355	Pc TrngL
A 4	on	355	Pc TrngL
A#4	on	353	Pc Shaker
B 4	on	357	Pc JnglBl
C 5	on	370	Dr BdStd
C#5	on	394	Dr SdRim1
D 5	on	382	Dr SdBldH
D#5	on	387	Dr SdHvy
E 5	on	392	Dr SdVar1
F 5	on	393	Dr SdVar2
F#5	on	396	Dr SdAmb1
G 5	on	383	Dr SdFsnH
G#5	on	398	Dr SdAmb3
A 5	on	388	Dr SdPclH
A#5	on	372	Dr BdHby
B 5	on	372	Dr BdHby
C 6	on	373	Dr BdLoJz

2 House Kit

Note	ElmAsgn	Wave No.	Wave Name
C 0	off		
C#0	off		
D 0	off		
D#0	off		
E 0	on	433	Dr Crash
F 0	on	373	Dr BdLoJz
F#0	on	367	Pc CONG
G 0	on	382	Dr SdBldH
G#0	on	367	Pc CONG
A 0	on	476	Dr EuroBD
A#0	on	437	Dr T8BdBm
B 0	on	457	Dr T9BD2
C 1	on	458	Dr T9BD3
C#1	on	466	Dr T9Rim
D 1	on	460	Dr T9SD2
D#1	on	444	Dr T8Rmst
E 1	on	463	Dr T9SD5
F 1	on	467	Dr T9TomL
F#1	on	470	Dr T9HHC1
G 1	on	468	Dr T9TomM
G#1	on	471	Dr T9HHC2
A 1	on	469	Dr T9TomH
A#1	on	472	Dr T9HHO1
B 1	on	469	Dr T9TomH
C 2	on	473	Dr T9HHO2
C#2	on	474	Dr T9Crsh
D 2	on	475	Dr T9Ride
D#2	on	465	Dr T9Clap
E 2	on	362	Pc AnvlPp
F 2	on	456	Dr T9BD1
F#2	on	389	Dr SdPcBH
G 2	on	369	Pc WdBk
G#2	on	362	Pc AnvlPp
A 2	on	367	Pc CONG
A#2	on	361	Pc AnvlHt
B 2	on	368	Pc StlClp
C 3	on	366	Pc Ripper
C#3	on	367	Pc CONG
D 3	on	452	Dr T8CngH
D#3	on	452	Dr T8CngH
E 3	on	452	Dr T8CngH
F 3	on	452	Dr T8CngH
F#3	on	449	Dr T8Crsh
G 3	on	447	Dr T8HHCl
G#3	on	448	Dr T8HHOp
A 3	on	355	Pc TrngL
A#3	on	455	Dr T8Mrscs
B 3	on	355	Pc TrngL
C 4	on	353	Pc Shaker
C#4	on	361	Pc AnvlHt
D 4	on	361	Pc AnvlHt
D#4	on	454	Dr T8Clve
E 4	on	365	Pc VoxDrm
F 4	on	477	Dr DstKik
F#4	on	449	Dr T8Crsh
G 4	on	357	Pc JnglBl
G#4	on	354	Pc Tmborn
A 4	on	354	Pc Tmborn
A#4	on	322	Fx BigSyn
B 4	on	322	Fx BigSyn
C 5	on	319	Fx Melow
C#5	on	328	Fx VxAlk
D 5	on	328	Fx VxAlk
D#5	on	328	Fx VxAlk
E 5	on	439	Dr T8SD1
F 5	on	359	Pc Whistl
F#5	on	388	Dr SdPclH
G 5	on	437	Dr T8BdBm
G#5	off		
A 5	off		
A#5	off		
B 5	off		
C 6	off		

3 Hip Kit

Note	ElmAsgn	Wave No.	Wave Name
C 0	on	477	Dr DstKik
C#0	on	378	Dr BdVar5
D 0	on	377	Dr BdVar4
D#0	on	437	Dr T8BdBm
E 0	on	456	Dr T9BD1
F 0	on	382	Dr SdBldH
F#0	on	388	Dr SdPclH
G 0	on	390	Dr SdPrmH
G#0	on	439	Dr T8SD1
A 0	on	399	Dr SdBkbt
A#0	on	404	Dr SdBrsL
B 0	on	437	Dr T8BdBm
C 1	on	379	Dr BdAna
C#1	on	407	Dr C.Rim2
D 1	on	394	Dr SdRim1
D#1	on	445	Dr T8Clap
E 1	on	389	Dr SdPcBH
F 1	on	409	Dr TomF
F#1	on	420	Dr HHCL2
G 1	on	409	Dr TomF
G#1	on	447	Dr T8HHCl
A 1	on	410	Dr TomL
A#1	on	426	Dr HHOpn
B 1	on	411	Dr TomM
C 2	on	412	Dr TomHL
C#2	on	433	Dr Crash
D 2	on	413	Dr TomHH
D#2	on	430	Dr Ride2
E 2	on	435	Dr China
F 2	on	432	Dr Cup2
F#2	on	354	Pc Tmborn
G 2	on	434	Dr Crash2
G#2	on	367	Pc CONG
A 2	on	434	Dr Crash2
A#2	on	356	Pc VbSlp
B 2	on	429	Dr Ride
C 3	on	331	Fx AHoseL
C#3	on	332	Fx AHoseR
D 3	on	339	Pc CngSlp
D#3	on	338	Pc CongaH
E 3	on	337	Pc CongaL
F 3	on	345	Pc TmbIsH
F#3	on	344	Pc TmbIsL
G 3	on	362	Pc AnvlPp
G#3	on	362	Pc AnvlPp
A 3	on	353	Pc Shaker
A#3	on	352	Pc Maracs
B 3	on	363	Pc Scrch1
C 4	on	438	Dr T8Bd
C#4	on	368	Pc StlClp
D 4	on	383	Dr SdFsnH
D#4	on	465	Dr T9Clap
E 4	on	393	Dr SdVar2
F 4	on	357	Pc JnglBl
F#4	on	470	Dr T9HHC1
G 4	on	355	Pc TrngL
G#4	on	471	Dr T9HHC2
A 4	on	355	Pc TrngL
A#4	on	472	Dr T9HHO1
B 4	on	329	Fx HiLo
C 5	on	325	Fx Eery
C#5	on	474	Dr T9Crsh
D 5	on	435	Dr China
D#5	on	318	Fx VoxBel
E 5	on	319	Fx Melow
F 5	on	255	Wv MogBs1
F#5	on	354	Pc Tmborn
G 5	on	364	Pc Scrch2
G#5	on	475	Dr T9Ride
A 5	on	325	Fx Eery
A#5	on	327	FX HH Hit
B 5	on	323	Fx TrnCho
C 6	on	323	Fx TrnCho

4 Trance Kit

Note	ElmAsgn	Wave No.	Wave Name
C 0	on	437	Dr T8BdBm
C#0	on	451	Dr T8CngM
D 0	on	438	Dr T8Bd
D#0	on	452	Dr T8CngH
E 0	on	457	Dr T9BD2
F 0	on	457	Dr T9BD2
F#0	on	367	Pc CONG
G 0	on	459	Dr T9SD1
G#0	on	367	Pc CONG
A 0	on	476	Dr EuroBD
A#0	on	476	Dr EuroBD
B 0	on	457	Dr T9BD2
C 1	on	458	Dr T9BD3
C#1	on	466	Dr T9Rim
D 1	on	459	Dr T9SD1
D#1	on	477	Dr DstKik
E 1	on	462	Dr T9SD4
F 1	on	467	Dr T9TomL
F#1	on	470	Dr T9HHC1
G 1	on	468	Dr T9TomM
G#1	on	471	Dr T9HHC2
A 1	on	469	Dr T9TomH
A#1	on	472	Dr T9HHO1
B 1	on	469	Dr T9TomH
C 2	on	473	Dr T9HHO2
C#2	on	474	Dr T9Crsh
D 2	on	475	Dr T9Ride
D#2	on	465	Dr T9Clap
E 2	on	362	Pc AnvlPp
F 2	on	456	Dr T9BD1
F#2	on	389	Dr SdPcBH
G 2	on	369	Pc WdBk
G#2	on	362	Pc AnvlPp
A 2	on	366	Pc Ripper
A#2	on	361	Pc AnvlHt
B 2	on	368	Pc StlClp
C 3	on	437	Dr T8BdBm
C#3	on	367	Pc CONG
D 3	on	452	Dr T8CngH
D#3	on	452	Dr T8CngH
E 3	on	452	Dr T8CngH
F 3	on	452	Dr T8CngH
F#3	on	449	Dr T8Crsh
G 3	on	447	Dr T8HHCl
G#3	on	448	Dr T8HHOp
A 3	on	355	Pc TrngL
A#3	on	455	Dr T8Mrscs
B 3	on	355	Pc TrngL
C 4	on	320	Fx WndChm
C#4	on	321	Fx BelAir
D 4	on	322	Fx BigSyn
D#4	on	326	Fx Electr
E 4	on	327	FX HH Hit
F 4	on	328	Fx VxAlk
F#4	on	328	Fx VxAlk
G 4	on	329	Fx HiLo
G#4	on	329	Fx HiLo
A 4	on	318	Fx VoxBel
A#4	on	318	Fx VoxBel
B 4	on	325	Fx Eery
C 5	on	258	Wv FMBs1
C#5	on	258	Wv FMBs1
D 5	on	258	Wv FMBs1
D#5	on	258	Wv FMBs1
E 5	on	258	Wv FMBs1
F 5	on	258	Wv FMBs1
F#5	on	258	Wv FMBs1
G 5	on	258	Wv FMBs1
G#5	on	258	Wv FMBs1
A 5	on	258	Wv FMBs1
A#5	on	258	Wv FMBs1
B 5	on	258	Wv FMBs1
C 6	on	258	Wv FMBs1

5 Nasty Kit

Note	ElmAsgn	Wave No.	Wave Name
C 0	on	438	Dr T8Bd
C#0	on	377	Dr BdVar4
D 0	on	337	Pc CongaL
D#0	on	379	Dr BdAna
E 0	on	458	Dr T9BD3
F 0	on	397	Dr SdAmb2
F#0	on	395	Dr SdRim2
G 0	on	439	Dr T8SD1
G#0	on	441	Dr T8SD3
A 0	on	403	Dr SdBrsH
A#0	on	398	Dr SdAmb3
B 0	on	476	Dr EuroBD
C 1	on	458	Dr T8BD3
C#1	on	329	Fx HilLo
D 1	on	462	Dr T9SD4
D#1	on	445	Dr T8Clap
E 1	on	369	Pc WdBk
F 1	on	314	Wv Noise
F#1	on	423	Dr HHCl5
G 1	on	314	Wv Noise
G#1	on	470	Dr T9HHCl
A 1	on	314	Wv Noise
A#1	on	472	Dr T9HHO1
B 1	on	418	Dr Tom2L
C 2	on	417	Dr Tom2H
C#2	on	474	Dr T9Crsh
D 2	on	417	Dr Tom2H
D#2	on	325	Fx Eery
E 2	on	435	Dr China
F 2	on	432	Dr Cup2
F#2	on	354	Pc Tmborn
G 2	on	433	Dr Crash
G#2	on	255	Wv MogBs1
A 2	on	434	Dr Crash2
A#2	on	356	Pc VbSlp
B 2	on	429	Dr Ride
C 3	on	328	Fx VxAlk
C#3	on	327	FX HH Hit
D 3	on	345	Pc TmbIsH
D#3	on	338	Pc CongaH
E 3	on	337	Pc CongaL
F 3	on	321	Fx BelAir
F#3	on	326	Fx Electr
G 3	on	362	Pc AnvLPp
G#3	on	362	Pc AnvLPp
A 3	on	353	Pc Shaker
A#3	on	352	Pc Maracs
B 3	on	360	Pc Bltree
C 4	on	438	Dr T8Bd
C#4	on	318	Fx VoxBel
D 4	on	397	Dr SdAmb2
D#4	on	465	Dr T9Clap
E 4	on	394	Dr SdRim1
F 4	on	330	Fx MltPno
F#4	on	447	Dr T8HHCl
G 4	on	361	Pc AnvLHt
G#4	on	471	Dr T9HHCl
A 4	on	361	Pc AnvLHt
A#4	on	448	Dr T8HHOp
B 4	on	325	Fx Eery
C 5	on	325	Fx Eery
C#5	on	474	Dr T9Crsh
D 5	on	435	Dr China
D#5	on	318	Fx VoxBel
E 5	on	449	Dr T8Crsh
F 5	on	209	En VxNoiz
F#5	on	354	Pc Tmborn
G 5	on	366	Pc Ripper
G#5	on	475	Dr T9Ride
A 5	on	450	Dr T8CngL
A#5	on	451	Dr T8CngM
B 5	on	416	Dr TmJzH
C 6	on	448	Dr T8HHOp

6 Brush Kit

Note	ElmAsgn	Wave No.	Wave Name
C 0	on	350	Pc Claves
C#0	on	404	Dr SdBrsL
D 0	on	401	Dr SdSwep
D#0	on	403	Dr SdBrsH
E 0	on	401	Dr SdSwep
F 0	on	405	Dr SdRoll
F#0	on	351	Pc Castnt
G 0	on	404	Dr SdBrsL
G#0	on	408	Dr Stick
A 0	on	376	Dr BdVar3
A#0	on	403	Dr SdBrsH
B 0	on	377	Dr BdVar4
C 1	on	373	Dr BdLoJz
C#1	on	403	Dr SdBrsH
D 1	on	404	Dr SdBrsL
D#1	on	358	Pc Clap
E 1	on	402	Dr SdBrsS
F 1	on	414	Dr TmJzL
F#1	on	422	Dr HHCl4
G 1	on	414	Dr TmJzL
G#1	on	424	Dr HHPdl
A 1	on	414	Dr TmJzL
A#1	on	426	Dr HHOpn
B 1	on	415	Dr TmJzM
C 2	on	416	Dr TmJzH
C#2	on	433	Dr Crash
D 2	on	416	Dr TmJzH
D#2	on	429	Dr Ride
E 2	on	430	Dr Ride2
F 2	on	431	Dr Cup
F#2	on	354	Pc Tmborn
G 2	on	434	Dr Crash2
G#2	on	340	Pc Cowbel
A 2	on	434	Dr Crash2
A#2	on	429	Dr Ride
B 2	on	432	Dr Cup2
C 3	on	336	Pc BongoH
C#3	on	335	Pc BongoL
D 3	on	339	Pc CngSlp
D#3	on	338	Pc CongaH
E 3	on	337	Pc CongaL
F 3	on	345	Pc TmbIsH
F#3	on	344	Pc TmbIsL
G 3	on	341	Pc AgogoL
G#3	on	341	Pc AgogoL
A 3	on	349	Pc Cabasa
A#3	on	352	Pc Maracs
B 3	on	359	Pc Whistl
C 4	on	359	Pc Whistl
C#4	on	343	Pc GiroCl
D 4	on	342	Pc GuiroL
D#4	on	350	Pc Claves
E 4	on	348	Pc Wdbkck
F 4	on	348	Pc Wdbkck
F#4	on	346	Pc Cuical
G 4	on	347	Pc CuicaH
G#4	on	355	Pc TrangL
A 4	on	355	Pc TrangL
A#4	on	353	Pc Shaker
B 4	on	357	Pc JnglBl
C 5	on	360	Pc Bltree
C#5	off		
D 5	off		
D#5	off		
E 5	off		
F 5	off		
F#5	off		
G 5	off		
G#5	off		
A 5	off		
A#5	off		
B 5	off		
C 6	off		

7 Pop Kit

Note	ElmAsgn	Wave No.	Wave Name
C 0	on	350	Pc Claves
C#0	on	404	Dr SdBrsL
D 0	on	401	Dr SdSwep
D#0	on	403	Dr SdBrsH
E 0	on	401	Dr SdSwep
F 0	on	405	Dr SdRoll
F#0	on	351	Pc Castnt
G 0	on	400	Dr SdDry
G#0	on	408	Dr Stick
A 0	on	376	Dr BdVar3
A#0	on	389	Dr SdPcBH
B 0	on	377	Dr BdVar4
C 1	on	372	Dr BdHby
C#1	on	406	Dr C.Rim1
D 1	on	380	Dr SdGM
D#1	on	358	Pc Clap
E 1	on	380	Dr SdGM
F 1	on	410	Dr TomL
F#1	on	423	Dr HHCl5
G 1	on	410	Dr TomL
G#1	on	425	Dr HHPdl2
A 1	on	411	Dr TomM
A#1	on	427	Dr HHOpn2
B 1	on	411	Dr TomM
C 2	on	412	Dr TomHL
C#2	on	433	Dr Crash
D 2	on	413	Dr TomHH
D#2	on	429	Dr Ride
E 2	on	435	Dr China
F 2	on	431	Dr Cup
F#2	on	354	Pc Tmborn
G 2	on	434	Dr Crash2
G#2	on	340	Pc Cowbel
A 2	on	434	Dr Crash2
A#2	on	356	Pc VbSlp
B 2	on	432	Dr Cup2
C 3	on	336	Pc BongoH
C#3	on	335	Pc BongoL
D 3	on	339	Pc CngSlp
D#3	on	338	Pc CongaH
E 3	on	337	Pc CongaL
F 3	on	345	Pc TmbIsH
F#3	on	344	Pc TmbIsL
G 3	on	341	Pc AgogoL
G#3	on	341	Pc AgogoL
A 3	on	349	Pc Cabasa
A#3	on	352	Pc Maracs
B 3	on	359	Pc Whistl
C 4	on	359	Pc Whistl
C#4	on	343	Pc GiroCl
D 4	on	342	Pc GuiroL
D#4	on	350	Pc Claves
E 4	on	348	Pc Wdbkck
F 4	on	348	Pc Wdbkck
F#4	on	346	Pc Cuical
G 4	on	347	Pc CuicaH
G#4	on	355	Pc TrangL
A 4	on	355	Pc TrangL
A#4	on	353	Pc Shaker
B 4	on	357	Pc JnglBl
C 5	on	360	Pc Bltree
C#5	on	399	Dr SdBkbt
D 5	on	381	Dr SdBldS
D#5	on	392	Dr SdVar1
E 5	on	386	Dr SdSonD
F 5	on	394	Dr SdRim1
F#5	on	391	Dr SdWdH
G 5	on	382	Dr SdBldH
G#5	on	389	Dr SdPcBH
A 5	on	384	Dr SdLdwH
A#5	on	371	Dr BdPop
B 5	on	372	Dr BdHby
C 6	on	378	Dr BdVar5

8 8o8 Kit

Note	ElmAsgn	Wave No.	Wave Name
C 0	on	350	Pc Claves
C#0	on	404	Dr SdBrsL
D 0	on	401	Dr SdSwep
D#0	on	403	Dr SdBrsH
E 0	on	401	Dr SdSwep
F 0	on	405	Dr SdRoll
F#0	on	351	Pc Castnt
G 0	on	442	Dr T8SD4
G#0	on	444	Dr T8Rmst
A 0	on	379	Dr BdAna
A#0	on	441	Dr T8SD3
B 0	on	437	Dr T8BdBm
C 1	on	438	Dr T8Bd
C#1	on	443	Dr T8Side
D 1	on	439	Dr T8SD1
D#1	on	445	Dr T8Clap
E 1	on	440	Dr T8SD2
F 1	on	446	Dr T8Tom
F#1	on	447	Dr T8HHCl
G 1	on	446	Dr T8Tom
G#1	on	448	Dr T8HHOp
A 1	on	446	Dr T8Tom
A#1	on	448	Dr T8HHOp
B 1	on	446	Dr T8Tom
C 2	on	446	Dr T8Tom
C#2	on	449	Dr T8Crsh
D 2	on	446	Dr T8Tom
D#2	on	449	Dr T8Crsh
E 2	on	435	Dr China
F 2	on	431	Dr Cup
F#2	on	354	Pc Tmborn
G 2	on	434	Dr Crash2
G#2	on	453	Dr T8Cwbl
A 2	on	434	Dr Crash2
A#2	on	356	Pc VbSlp
B 2	on	430	Dr Ride2
C 3	on	336	Pc BongoH
C#3	on	335	Pc BongoL
D 3	on	452	Dr T8CngH
D#3	on	451	Dr T8CngM
E 3	on	450	Dr T8CngL
F 3	on	345	Pc TmbIsH
F#3	on	344	Pc TmbIsL
G 3	on	341	Pc AgogoL
G#3	on	341	Pc AgogoL
A 3	on	349	Pc Cabasa
A#3	on	455	Dr T8Mracs
B 3	on	359	Pc Whistl
C 4	on	359	Pc Whistl
C#4	on	343	Pc GiroCl
D 4	on	342	Pc GuiroL
D#4	on	454	Dr T8Clve
E 4	on	348	Pc Wdbkck
F 4	on	348	Pc Wdbkck
F#4	on	346	Pc Cuical
G 4	on	347	Pc CuicaH
G#4	on	355	Pc TrangL
A 4	on	355	Pc TrangL
A#4	on	353	Pc Shaker
B 4	on	357	Pc JnglBl
C 5	on	360	Pc Bltree
C#5	off		
D 5	off		
D#5	off		
E 5	off		
F 5	off		
F#5	off		
G 5	off		
G#5	off		
A 5	off		
A#5	off		
B 5	off		
C 6	off		

Internal (MSB=63, LSB=32)

1 HipHop Kit

Note	ElmAsgn	Wave No.	Wave Name
C 0	on	437	Dr T8BdBm
C#0	on	440	Dr T8SD2
D 0	on	439	Dr T8SD1
D#0	on	441	Dr T8SD3
E 0	on	442	Dr T8SD4
F 0	on	462	Dr T9SD4
F#0	on	327	FX HH Hit
G 0	on	460	Dr T9SD2
G#0	on	444	Dr T8Rmst
A 0	on	438	Dr T8Bd
A#0	on	463	Dr T9SD5
B 0	on	458	Dr T9BD3
C 1	on	456	Dr T9BD1
C#1	on	406	Dr C.Rim1
D 1	on	459	Dr T9SD1
D#1	on	465	Dr T9Clap
E 1	on	461	Dr T9SD3
F 1	on	467	Dr T9TomL
F#1	on	471	Dr T9HHCl2
G 1	on	467	Dr T9TomL
G#1	on	473	Dr T9HHO2
A 1	on	468	Dr T9TomM
A#1	on	472	Dr T9HHO1
B 1	on	468	Dr T9TomM
C 2	on	469	Dr T9TomH
C#2	on	474	Dr T9Crsh
D 2	on	469	Dr T9TomH
D#2	on	475	Dr T9Ride
E 2	on	449	Dr T8Crsh
F 2	on	475	Dr T9Ride
F#2	on	354	Pc Tmborn
G 2	on	449	Dr T8Crsh
G#2	on	453	Dr T8Cwbl
A 2	on	474	Dr T9Crsh
A#2	on	477	Dr DstKik
B 2	on	449	Dr T8Crsh
C 3	on	452	Dr T8CngH
C#3	on	450	Dr T8CngL
D 3	on	451	Dr T8CngM
D#3	on	255	Wv MogBs1
E 3	on	266	Wv Late-S
F 3	on	399	Dr SdBkbt
F#3	on	399	Dr SdBkbt
G 3	on	453	Dr T8Cwbl
G#3	on	341	Pc AgogoL
A 3	on	349	Pc Cabasa
A#3	on	455	Dr T8MrCs
B 3	on	329	Fx HiLo
C 4	on	329	Fx HiLo
C#4	on	361	Pc AnvlHt
D 4	on	366	Pc Ripper
D#4	on	454	Dr T8Clve
E 4	on	454	Dr T8Clve
F 4	on	351	Pc Castnt
F#4	on	363	Pc Scrch1
G 4	on	364	Pc Scrch2
G#4	on	355	Pc TrngL
A 4	on	355	Pc TrngL
A#4	on	353	Pc Shaker
B 4	on	357	Pc JnglBl
C 5	on	360	Pc Bltree
C#5	on	394	Dr SdRim1
D 5	on	388	Dr SdPclH
D#5	on	358	Pc Clap
E 5	on	390	Dr SdPrmH
F 5	on	379	Dr BdAna
F#5	on	447	Dr T8HHCl
G 5	on	457	Dr T9BD2
G#5	on	423	Dr HHCl5
A 5	on	374	Dr BdVar1
A#5	on	448	Dr T8HHOp
B 5	on	476	Dr EuroBD
C 6	on	372	Dr BdHby

2 Urbanguard

Note	ElmAsgn	Wave No.	Wave Name
C 0	on	378	Dr BdVar5
C#0	on	404	Dr SdBrsL
D 0	on	401	Dr SdSweP
D#0	on	403	Dr SdBrsH
E 0	on	401	Dr SdSweP
F 0	on	405	Dr SdRoll
F#0	on	314	Wv Noise
G 0	on	385	Dr SdSonA
G#0	on	408	Dr Stck
A 0	on	378	Dr BdVar5
A#0	on	389	Dr SdPcBH
B 0	on	375	Dr BdVar2
C 1	on	373	Dr BdLoJz
C#1	on	407	Dr C.Rim2
D 1	on	380	Dr SdGM
D#1	on	358	Pc Clap
E 1	on	391	Dr SdWdH
F 1	on	409	Dr TomF
F#1	on	419	Dr HHCl1
G 1	on	410	Dr TomL
G#1	on	424	Dr HHPdl
A 1	on	410	Dr TomL
A#1	on	426	Dr HHOpn
B 1	on	411	Dr TomM
C 2	on	412	Dr TomHL
C#2	on	433	Dr Crash
D 2	on	413	Dr TomHH
D#2	on	429	Dr Ride
E 2	on	435	Dr China
F 2	on	431	Dr Cup
F#2	on	354	Pc Tmborn
G 2	on	434	Dr Crash2
G#2	on	453	Dr T8Cwbl
A 2	on	434	Dr Crash2
A#2	on	356	Pc VbSlp
B 2	on	449	Dr T8Crsh
C 3	on	336	Pc BongoH
C#3	on	335	Pc BongoL
D 3	on	339	Pc CngSlp
D#3	on	338	Pc CongaH
E 3	on	337	Pc CongaL
F 3	on	345	Pc TmbIsH
F#3	on	344	Pc TmbIsL
G 3	on	341	Pc AgogoL
G#3	on	341	Pc AgogoL
A 3	on	349	Pc Cabasa
A#3	on	352	Pc Maracs
B 3	on	359	Pc Whistl
C 4	on	359	Pc Whistl
C#4	on	343	Pc GiroCl
D 4	on	342	Pc GuiroL
D#4	on	350	Pc Claves
E 4	on	348	Pc Wdblck
F 4	on	348	Pc Wdblck
F#4	on	346	Pc CuicaL
G 4	on	347	Pc CuicaH
G#4	on	355	Pc TrngL
A 4	on	355	Pc TrngL
A#4	on	353	Pc Shaker
B 4	on	357	Pc JnglBl
C 5	on	360	Pc Bltree
C#5	on	477	Dr DstKik
D 5	on	477	Dr DstKik
D#5	on	477	Dr DstKik
E 5	on	477	Dr DstKik
F 5	on	477	Dr DstKik
F#5	on	477	Dr DstKik
G 5	on	477	Dr DstKik
G#5	on	477	Dr DstKik
A 5	on	477	Dr DstKik
A#5	on	477	Dr DstKik
B 5	on	477	Dr DstKik
C 6	on	477	Dr DstKik

Wave List

No.	Cat./WaveName	No.	Cat./WaveName	No.	Cat./WaveName	No.	Cat./WaveName	No.	Cat./WaveName	No.	Cat./WaveName	No.	Cat./WaveName
1	Pf Grand	86	Or D1 1/3	171	Gt Single	256	Wv MogBs2	341	Pc AgogoL	426	Dr HHOpn	511	Pf Rho5M-
2	Pf Grand+	87	Or D1	172	Gt SnglHl	257	Wv MogBs3	342	Pc GuiroL	427	Dr HHOpn2	512	Pf Rho5L-
3	Pf Grand-	88	Or LesGrt	173	Gt StrtF	258	Wv FMBs1	343	Pc GiroCl	428	Dr HHTip	513	Pf Rho6H
4	Pf Brit	89	Or LesGr2	174	Gt ES335	259	Wv FMBs2	344	Pc TmbIsL	429	Dr Ride	514	Pf Rho6L
5	Pf Brit+	90	Or Rotar	175	Gt DistCl	260	Wv FMBs3	345	Pc TmbIsH	430	Dr Ride2	515	Pf Rho6L+
6	Pf Brit-	91	Or Clack	176	Gt DistMt	261	Wv FMBs4	346	Pc CuicaL	431	Dr Cup	516	Pf Rho6L+
7	Pf CP80	92	Or LesWho	177	Gt FeedBk	262	Wv FMBs5	347	Pc CuicaH	432	Dr Cup2	517	Pf Rho6H-
8	Pf CP80+	93	Or SftTmp	178	Gt StlHrm	263	Wv FMBs6	348	Pc WdbLck	433	Dr Crash	518	Pf Rho6L-
9	Pf CP80-	94	Or Perc	179	Gt StrHrm	264	Wv FmFnk	349	Pc Cabasa	434	Dr Crash2	519	Or Pipe1St
10	Pf Rho1P	95	Or Perc+	180	Gt Dist2	265	Wv FMGr	350	Pc Claves	435	Dr China	520	Or Pipe1L
11	Pf Rho1P+	96	Or Perc-	181	Ba Acstic	266	Wv Late-S	351	Pc Castnt	436	Dr China2	521	Or Pipe1R
12	Pf Rho1P-	97	Or Harmnc	182	Ba Acstc+	267	Wv Late-L	352	Pc Maracs	437	Dr T8BdBm	522	Or Pipe2
13	Pf Rho1L	98	Or Acrdn	183	Ba Acstc-	268	Wv P5Saw	353	Pc Shaker	438	Dr T8Bd	523	Or Pipe3St
14	Pf Rho1L+	99	Or Acrdn+	184	Ba Fing	269	Wv Saw2	354	Pc Tmborn	439	Dr T8SD1	524	Or Pipe3L
15	Pf Rho1L-	100	Or Acrdn-	185	Ba Fing+	270	Wv 1o1Saw	355	Pc TrngL	440	Dr T8SD2	525	Or Pipe3R
16	Pf Rho2S	101	Cp FngCym	186	Ba Fing-	271	Wv 1o1Sub	356	Pc VbSlp	441	Dr T8SD3	526	Or Pipe4
17	Pf Rho2S+	102	Cp Hibasi	187	Ba Harmnc	272	Wv SawSqu	357	Pc JnglBl	442	Dr T8SD4	527	Or Pipe5
18	Pf Rho2S-	103	Cp StoneH	188	Ba Precsn	273	Wv SquSaw	358	Pc Clap	443	Dr T8Side	528	Or Pipe6
19	Pf Rho2M	104	Cp StoneS	189	Ba Prcsn+	274	Wv MgRamp	359	Pc Whistl	444	Dr T8Rmst	529	Or Pipe7
20	Pf Rho2M+	105	Cp Gamln1	190	Ba Pecsn-	275	Wv P10-1	360	Pc Bltree	445	Dr T8Clap	530	En AahSt
21	Pf Rho2M-	106	Cp Gamln2	191	Ba PrsRw	276	Wv P10-2	361	Pc AnvlHt	446	Dr T8Tom	531	En AahL
22	Pf Rho2H	107	Cp Glock	192	Ba PrsRw+	277	Wv P10-3	362	Pc AnvlPp	447	Dr T8HHCl	532	En AahR
23	Pf Rho2H+	108	Cp Marimb	193	Ba PrsRw-	278	Wv P25-1	363	Pc Scrch1	448	Dr T8HHOp	533	En AahC
24	Pf Rho2H-	109	Cp Vibra	194	Ba Pick	279	Wv P25-2	364	Pc Scrch2	449	Dr T8Crsh	534	En AahSt+
25	Pf Rho3	110	Cp Xylo	195	Ba Slap	280	Wv P50-1	365	Pc VoxDrm	450	Dr T8CngL	535	En AahL+
26	Pf Rho3+	111	Cp HndBel	196	Ba Slap+	281	Wv P50-2	366	Pc Ripper	451	Dr T8CngM	536	En AahR+
27	Pf Rho3-	112	Cp Crots	197	Ba Slap-	282	Wv Tri	367	Pc CONG	452	Dr T8CngH	537	En AahC+
28	Pf Rho4	113	Cp Timpni	198	Ba Slap2	283	Wv Digi01	368	Pc StClp	453	Dr T8Cwbl	538	En AahSt-
29	Pf Rho4+	114	Br SectnL	199	Ba Slap2+	284	Wv Digi02	369	Pc WdBlk	454	Dr T8Clve	539	En AahL-
30	Pf Rho4-	115	Br SectnR	200	Ba Slap2-	285	Wv Digi03	370	Dr BdStd	455	Dr T8Mrcs	540	En AahR-
31	Pf Wurli	116	Br SctnSt	201	Ba Frtl1	286	Wv Digi04	371	Dr BdPop	456	Dr T9BD1	541	En AahC-
32	Pf Wurli+	117	Br SctnL-	202	Ba Frtl1+	287	Wv Digi05	372	Dr BdHby	457	Dr T9BD2	542	En OohSt
33	Pf Wurli-	118	Br SctnR-	203	Ba Frtl1-	288	Wv Digi06	373	Dr BdLoJz	458	Dr T9BD3	543	En OohL
34	Pf DX1	119	Br SctSt-	204	Ba Frtl2	289	Wv Digi07	374	Dr BdVar1	459	Dr T9SD1	544	En OohR
35	Pf DX2	120	Br Sctn2L	205	Ba Frtl2+	290	Wv Digi08	375	Dr BdVar2	460	Dr T9SD2	545	En OohRich
36	Pf DX3	121	Br Sctn2R	206	Ba Frtl2-	291	Wv Digi09	376	Dr BdVar3	461	Dr T9SD3	546	En OohSt+
37	Pf Clav1	122	Br Sct2St	207	Ba SyBass	292	Wv Digi10	377	Dr BdVar4	462	Dr T9SD4	547	En OohL+
38	Pf Clav1+	123	Br Sct2L+	208	En SynVox	293	Wv Digi11	378	Dr BdVar5	463	Dr T9SD5	548	En OohR+
39	Pf Clav1-	124	Br SctnR+	209	En VxNoiz	294	Wv Digi12	379	Dr BdAna	464	Dr T9SD6	549	En OohRich+
40	Pf Clav2	125	Br Sct2S+	210	En Aah	295	Wv Bel1Wv	380	Dr SdGM	465	Dr T9Clap	550	En OohSt-
41	Pf Clav2+	126	Br Sct2L-	211	En Aah+	296	Wv Bel2Wv	381	Dr SdBldS	466	Dr T9Rim	551	En OohL-
42	Pf Clav2-	127	Br Sct2R-	212	En Aah-	297	Wv DgVox1	382	Dr SdBldH	467	Dr T9TomL	552	En OohR-
43	Pf Clav3	128	Br Sct2S-	213	En Oooo	298	Wv DgVox2	383	Dr SdFsnH	468	Dr T9TomM	553	En OohRich-
44	Pf Clav3+	129	Br Trmbn	214	En Oooo+	299	Wv DgVox3	384	Dr SdLdwH	469	Dr T9TomH		
45	Pf Clav3-	130	Br Trmbn-	215	En Oooo-	300	Wv DgVox4	385	Dr SdSonA	470	Dr T9HHC1		
46	Pf Hrpscd	131	Br SftTrb	216	En Itopia	301	Wv DgVox5	386	Dr SdSonD	471	Dr T9HHC2		
47	Or JmPrc	132	Br SftFlg	217	Rd Alto	302	Wv VoxG2	387	Dr SdHvy	472	Dr T9HHO1		
48	Or JmPrc-	133	Br SftFl-	218	Rd Alto+	303	Wv VoxE3	388	Dr SdPclH	473	Dr T9HHO2		
49	Or Jazz	134	Br Hermn	219	Rd Alto-	304	Wv Ep1	389	Dr SdPcBH	474	Dr T9Crsh		
50	Or Jazz+	135	Br Strgt	220	Rd Tenor	305	Wv Ep2	390	Dr SdPrmH	475	Dr T9Ride		
51	Or Jazz-	136	Br TrpMed	221	Rd Tenor+	306	Wv Ep3	391	Dr SdWdH	476	Dr EuroBD		
52	Or Rock	137	Br TrpSft	222	Rd Tenor-	307	Wv Ep4	392	Dr SdVar1	477	Dr DstKik		
53	Or Rock+	138	Br Trmpt	223	Rd Bari	308	Wv Ep5	393	Dr SdVar2	478	Dr Bd Kit		
54	Or Rock-	139	Br Trmpt+	224	Rd BigSx1	309	Wv Ep6	394	Dr SdRim1	479	Dr Sn Kit		
55	Or Argent	140	Br Trmpt-	225	Rd BigSx2	310	Wv Org1Wv	395	Dr SdRim2	480	Pf Grand2		
56	Or BowVb	141	Br PiclTp	226	Rd SxBrth	311	Wv Org2Wv	396	Dr SdAmb1	481	Pf Grand2St		
57	Or BowNv	142	Br F.Horn	227	Rd Soprn	312	Wv Org3Wv	397	Dr SdAmb2	482	Pf Grand2L		
58	Or Gospel	143	Br Combi1	228	Rd Soprn+	313	Wv Sin	398	Dr SdAmb3	483	Pf Grand2R		
59	Or Green	144	Br Combi2	229	Rd Soprn-	314	Wv Noise	399	Dr SdBkbt	484	Pf Grand2+		
60	Or Santana	145	Br Combi3	230	Rd Clari	315	Wv PnoNP	400	Dr SdDry	485	Pf Grnd2St+		
61	Or Farfis	146	Br Combi4	231	Rd Clari+	316	Wv EPNP	401	Dr SdSwep	486	Pf Grand2L+		
62	Or Farfi-	147	St Vln	232	Rd Clari-	317	Wv VibeNP	402	Dr SdBrsS	487	Pf Grand2R+		
63	Or VoxOrg	148	St Vln2	233	Rd Oboe	318	Fx VoxBel	403	Dr SdBrsH	488	Pf Grand2-		
64	Or VxOrg-	149	St Cello	234	Rd Oboe+	319	Fx Melow	404	Dr SdBrsL	489	Pf Grnd2St-		
65	Or Swish	150	St EnsMx	235	Rd Oboe-	320	Fx WndChm	405	Dr SdRoll	490	Pf Grand2L-		
66	Or Swish-	151	St EnsMx-	236	Rd Basoon	321	Fx BelAir	406	Dr C.Rim1	491	Pf Grand2R-		
67	Or Dw1+3	152	St SmlEns	237	Rd Basoon+	322	Fx BigSyn	407	Dr C.Rim2	492	Pf Grand3		
68	Or Dw1+3+	153	St SmlEn+	238	Rd Basoon-	323	Fx TrnCho	408	Dr Stick	493	Pf Grand3St		
69	Or Dw1+3-	154	St SmlEn-	239	Pi Flute	324	Fx HanSol	409	Dr TomF	494	Pf Grand3L		
70	Or Dw2+4	155	St Pizz	240	Pi Flute+	325	Fx Eery	410	Dr TomL	495	Pf Grand3R		
71	Or Dw2+4+	156	St Pizz2	241	Pi Flute-	326	Fx Electr	411	Dr TomM	496	Pf Grand3+		
72	Or Dw2+4-	157	St Harp	242	Pi PnFlt	327	FX HH Hit	412	Dr TomHL	497	Pf Grnd3St+		
73	Or DrwEv	158	Gt Nylon	243	Pi PnFlt-	328	Fx VxAlk	413	Dr TomHH	498	Pf Grand3L+		
74	Or DrwEv+	159	Gt NylnHi	244	Wv ModSaw	329	Fx HiLo	414	Dr TmJzL	499	Pf Grand3R+		
75	Or DrwEv-	160	Gt Nylhrm	245	Wv ObStr	330	Fx MitPno	415	Dr TmJzM	500	Pf Grand3-		
76	Or DrwOd	161	Gt Steel	246	Wv JpStr	331	Fx AHoseL	416	Dr TmJzH	501	Pf Grnd3St-		
77	Or DrwOd+	162	Gt StelHi	247	Wv SyzStr	332	Fx AHoseR	417	Dr Tom2H	502	Pf Grand3L-		
78	Or DrwOd-	163	Gt StelLo	248	Wv Padd	333	Et StlDrm	418	Dr Tom2L	503	Pf Grand3R-		
79	Or D16	164	Gt JzGtr	249	Wv ObBrs	334	Et Sitar	419	Dr HHCl1	504	Pf Rho5H		
80	Or D5 1/3	165	Gt Strt	250	Wv SyncLd	335	Pc BongoL	420	Dr HHCl2	505	Pf Rho5M		
81	Or D8	166	Gt StrtN	251	Wv CS80Br	336	Pc BongoH	421	Dr HHCl3	506	Pf Rho5L		
82	Or D4	167	Gt StrtSl	252	Wv 3o3Saw	337	Pc CongaL	422	Dr HHCl4	507	Pf Rho5H+		
83	Or D2 2/3	168	Gt StrtSp	253	Wv 3o3Sw2	338	Pc CongaH	423	Dr HHCl5	508	Pf Rho5M+		
84	Or D2	169	Gt StrtMt	254	Wv 3o3Squ	339	Pc CngSlp	424	Dr HHPdl	509	Pf Rho5L+		
85	Or D1 3/5	170	Gt Front	255	Wv MogBs1	340	Pc Cowbel	425	Dr HHPdl2	510	Pf Rho5H-		

Performance List

Internal (MSB=63, LSB=64)

No.	Performance Name	Category	Notes
1(A01)	AGE2000NEW	Co	●
2(A02)	Hallelujah	Vo	
3(A03)	MetalPiano	Pf	
4(A04)	MayanMagic	Fx	
5(A05)	HipHop Pop	Co	●
6(A06)	Oktavian	Sc	
7(A07)	Bass/Piano	Co	
8(A08)	Overture	Fx	
9(A09)	Opus 12	St	
10(A10)	EP+Strings	Co	
11(A11)	MuteTrp/EP	Co	
12(A12)	Rock It!	Co	●
13(A13)	WhirlPool	Fx	
14(A14)	Marrakesh	Et	●
15(A15)	SuperStrgs	St	
16(A16)	Mysterioso	Pd	
17(B01)	Clockworks	Se	
18(B02)	ChurchEns	Co	
19(B03)	TX816 EP	Pf	
20(B04)	Neonist	Co	
21(B05)	Busta'	Co	●
22(B06)	Trancitar	Co	
23(B07)	Bss/Pno+EP	Co	
24(B08)	CirqDeAna	Co	●
25(B09)	ScratchIt	Co	●
26(B10)	EP/Strings	Co	
27(B11)	Sax/EP	Co	
28(B12)	Rollin'	Co	●
29(B13)	GuitInAPad	Co	
30(B14)	SafariTech	Et	●
31(B15)	Classical1	Co	
32(B16)	Horror	Se	See *1
33(C01)	Dreamloopr	Co	●
34(C02)	Messiah	Co	
35(C03)	CrystalPno	Pf	
36(C04)	Pad Sweep	Pd	
37(C05)	Ottomatic	Co	●
38(C06)	Rockie	Sc	
39(C07)	Club Blues	Co	
40(C08)	Drumantics	Dr	●
41(C09)	Fairy Dust	Co	
42(C10)	Piano&Str.	Co	
43(C11)	Bavarian	Co	
44(C12)	SlowGroove	Co	●
45(C13)	Bell&Str	Co	
46(C14)	Rezzies	Co	●
47(C15)	Classical2	Co	
48(C16)	911 Call	Se	
49(D01)	Seekwencer	Co	●
50(D02)	Sanctuary	Co	
51(D03)	Wire+Piano	Pf	
52(D04)	DeepBreeze	Pd	
53(D05)	DiscoDucks	Co	●
54(D06)	BigFive	Sc	
55(D07)	Bs/PercOrg	Co	
56(D08)	Night Byte	Sq	
57(D09)	Sonority	Co	
58(D10)	Folk Trio	Co	
59(D11)	Funk It!	Co	
60(D12)	Police Men	Co	●
61(D13)	2 Mini's	Ld	
62(D14)	Aquamarine	Co	●
63(D15)	Classical3	Co	
64(D16)	Nitechills	Se	

No.	Performance Name	Category	Notes
65(E01)	RayOfLight	Co	●
66(E02)	NotreDame	Co	
67(E03)	Montuno	Pf	
68(E04)	80Sphere	Pd	
69(E05)	Thelands	Co	●
70(E06)	SweepPerf	Sc	
71(E07)	Jazz It!	Co	
72(E08)	Mobutu	Se	●
73(E09)	Harp@Orch	Co	
74(E10)	PF/Strings	Co	
75(E11)	Gnu Age	Co	
76(E12)	Cookin'	Co	●
77(E13)	A.Gt/Lucky	Co	
78(E14)	PhazeEuro	Co	
79(E15)	Classical4	Co	
80(E16)	Scare-isma	Fx	See *1
81(F01)	Shagundala	Co	●
82(F02)	Sevenths	Br	
83(F03)	BreathPian	Pf	
84(F04)	It Grows!	Pd	
85(F05)	Flute Funk	Co	
86(F06)	Real World	Co	
87(F07)	Cool Vibe	Co	
88(F08)	Paradise	Co	●
89(F09)	Balladeer	Co	●
90(F10)	Strg/Piano	Co	
91(F11)	Barcelona	Co	●
92(F12)	Girl	Co	●
93(F13)	1973!	Co	
94(F14)	Flying	Co	●
95(F15)	Classical5	Co	
96(F16)	PatchCords	Fx	
97(G01)	Pops	--	
98(G02)	Ballad 1	--	
99(G03)	Ballad 2	--	
100(G04)	Unplugged	--	
101(G05)	80's Disco	--	
102(G06)	Funk Rock	--	
103(G07)	Hard Rock	--	
104(G08)	HeavyMetal	--	
105(G09)	ProgreRock	--	
106(G10)	Blues Rock	--	
107(G11)	West Coast	--	
108(G12)	BritishRck	--	
109(G13)	Big Band	--	
110(G14)	Combo Jazz	--	
111(G15)	JazzBallad	--	See *2
112(G16)	Fusion	--	
113(H01)	Club Jazz	--	
114(H02)	House	--	
115(H03)	Techno	--	
116(H04)	Trance	--	
117(H05)	Big Beat	--	
118(H06)	Drum'nBass	--	
119(H07)	HipHop	--	
120(H08)	Reggae	--	
121(H09)	R&B	--	
122(H10)	India	--	
123(H11)	Salsa	--	
124(H12)	Gamelan	--	
125(H13)	Ambient	--	
126(H14)	Tango	--	
127(H15)	SoundTrack	--	
128(H16)	Master KB	--	See *3

*1 Performances suitable for playing on the keyboard.

*2 Performances suitable for multi-part playback using sequencer function.

*3 Performances suitable for master keyboard settings.

Arpeggio Hold function is preset for the Performances marked with "●."

Turning Knob2 counterclockwise sets the Arpeggio function to off.

Control List

Control Set Destination Parameter

No.	LCD	Parameter
00	off	:off
01	Volume	Voice Volume
02	RevSend	Reverb Send
03	ChoSend	Chorus Send
04	INS1-P1:EF1	Insertion Effect 1 Parameter 1
:	:	:
13	INS1P10:EF1	Insertion Effect 1 Parameter 10
14	INS2-P1:EF2	Insertion Effect 2 Parameter 1
:	:	:
29	INS2P16:EF2	Insertion Effect 2 Parameter 16
30	CLFOspd	Common LFO Speed
31	CLFO-D1	Common LFO Depth1
32	CLFO-D2	Common LFO Depth2
33	PorTime	Common Portamento Time
34	ELM-Lvl	Element Level
35	ELM-Pan	Element Pan
36	ELM-Dly	Element Key On Delay
37	ELFOspd	Element LFO Speed
38	ELFO-PM	Element LFO Pitch Modulation Depth
39	ELFO-AM	Element LFO Amplitude Modulation Depth
40	ELFO-FM	Element LFO Filter Modulation Depth
41	PCH-Crs	Element Pitch Coarse
42	PCH-Fin	Element Pitch Fine
43	PEG-Dpt	Element Pitch EG Depth
44	PEG-Hld	Element Pitch EG Hold Time
45	PEG-Atk	Element Pitch EG Attack Time
46	PEG-D1	Element Pitch EG Decay1 Time
47	PEG-D2	Element Pitch EG Decay2 Time
48	PEG-Rel	Element Pitch EG Release Time
49	AEG-Atk	Element Amplitude EG Attack Time
50	AEG-D1	Element Amplitude EG Decay1 Time
51	AEG-D2	Element Amplitude EG Decay2 Time
52	AEG-Rel	Element Amplitude EG Release Time
53	FEG-Dpt	Element Filter EG Depth
54	FEG-Hld	Element Filter EG Hold Time
55	FEG-Atk	Element Filter EG Attack Time
56	FEG-D1	Element Filter EG Decay1 Time
57	FEG-D2	Element Filter EG Decay2 Time
58	FEG-Rel	Element Filter EG Release Time
59	FLT-Frq	Element Filter Cutoff Frequency
60	FLT-Rez	Element Filter Resonance
61	HPF-Frq	Element Filter HPF Cutoff Frequency

The destination parameters 00 - 29 can be used for all Controller Sets. However, in the case of the Plug-in voices, only the parameters 00 - 13 are available.

The parameters 30 - 61 are available for the Normal voices except for the Plug-in voices.

The parameters 04 - 29 are available only when Insertion effect is applied to the voice, and the effective parameter type differs depending on the currently selected effect type. If the destination parameter is effective, it's actual parameter name will be displayed on the LCD. For example, "INS1P10" of the number 13 will be replaced with the actual parameter name. If not, the LCD displays the one like "INS1P10" shown in the above list in the Controller Set function, and "-----" in the Play mode.

System Controller Destination Parameter

No.	LCD	Parameter
00	off	off
01	EQLow-G	MEQ Low Gain
02	EQLow-F	MEQ Low Frequency
03	EQLow-Q	MEQ Low Q
04	EQLoM-G	MEQ Low Mid Gain
05	EQLoM-F	MEQ Low Mid Frequency
06	EQLoM-Q	MEQ Low Mid Q
07	EQMid-G	MEQ Mid Gain
08	EQMid-F	MEQ Mid Frequency
09	EQMid-Q	MEQ Mid Q
10	EQHiM-G	MEQ High Mid Gain
11	EQHiM-F	MEQ High Mid Frequency
12	EQHiM-Q	MEQ High Mid Q
13	EQHi-G	MEQ High Gain
14	EQHi-F	MEQ High Frequency
15	EQHi-Q	MEQ High Q
16	REV-P1	ReverbParameter 1
:	:	:
25	REV-P10	Reverb Parameter 10
26	REV-Rtn	Reverb Return
27	REV-Pan	Reverb Pan
28	CHO-P1	Chorus Parameter 1
:	:	:
37	CHO-P10	Chorus Parameter 10
38	CHO-Rtn	Chorus Return
39	CHO-Pan	Chorus Pan
40	Cho>Rev	Send Chorus To Reverb
41	ARP-Typ	Arpeggio Type
42	ARP-Unt	Arpeggio Unit Multiply
43	ARP-Vel	Arpeggio Velocity Rate
44	ARP-Gat	Arpeggio Gate Time Rate
45	Tempo	Arpeggio/Sequencer Tempo
46	EG-Atck	QED EG Attack Time
47	EG-Decy	QED EG Decay Time
48	EG-SusL	QED EG Sustain Level
49	EG-Rele	QED EG Release Time
50	Cutoff	QED Cutoff Frequency
51	Reso	QED Resonance

As to the parameters 16 - 25 and 28 - 37, the effective parameter type differs depending on the currently selected effect type. If the destination parameter is effective, it's actual parameter name will be displayed on the LCD. For example, "REV-P10" of the number 25 will be replaced with the actual parameter name. If not, the LCD displays the one like "REV-P10" shown in the above list in the Controller Set function, and "-----" in the Play mode.

Arpeggio Type List

Control Change Number List

[CONTROLLER]

Name	No.	Remarks
PB:PITCH BEND		Pitch Bend
MW:MODULATION WHELL	1	Modulation
AT:AFTER TOUCH		After Touch
BC:BREATH CONTROLLER	(2)	Set in the Utility or Performance Mode
RB:RIBBON CONTROLLER	(22)	Set in the Utility or Performance Mode
FC:FOOT CONTROLLER	(11)	Set in the Utility or Performance Mode
FS:FOOT SWITCH	(64)	Set in the Utility Mode

[ASSIGNABLE KNOB]

Name	No.	Remarks
[KNOB A]	(18)	Set in the Utility Mode
[KNOB B]	(19)	Set in the Utility Mode
[KNOB C]	(20)	Set in the Utility Mode
[KNOB 1]	(16)	Set in the Utility or Performance Mode
[KNOB 2]	(17)	Set in the Utility or Performance Mode

The control numbers in the parentheses are the defaults.

No.	Name	No.	Name
1	UpOct1:Sq	65	SuperArp:Ph
2	UpOct2:Sq	66	MuteArp1:Ph
3	UpOct4:Sq	67	MuteArp2:Ph
4	DownOct1:Sq	68	VelGruv1:Ph
5	DownOct2:Sq	69	VelGruv2:Ph
6	DownOct4:Sq	70	SpaceArp:Ph
7	U/DAOct1:Sq	71	MuteLine:Ph
8	U/DAOct2:Sq	72	StepLine:Ph
9	U/DAOct4:Sq	73	AcidLine:Ph
10	U/DBOct1:Sq	74	SplitArp:Ph
11	U/DBOct2:Sq	75	Step Seq:Ph
12	U/DBOct4:Sq	76	PolyArp1:Ph
13	RndmOct1:Sq	77	PolyArp2:Ph
14	RndmOct2:Sq	78	Ana Seq:Ph
15	RndmOct4:Sq	79	Planet:Ph
16	Oct2Up:Sq	80	Rosync:Ph
17	Oct4Up:Sq	81	StrumArp:Ph
18	UnisonUp:Sq	82	Guit1Arp:Ph
19	Up&Down1:Sq	83	RolliArp:Ph
20	Up&Down2:Sq	84	Guit2Arp:Ph
21	Up&Down4:Sq	85	Guit3Arp:Ph
22	Up&Alt1:Sq	86	Guit4Arp:Ph
23	Up&Rndm1:Sq	87	Harp Arp:Ph
24	Up&Rndm2:Sq	88	BigBeat1:Dr
25	Up&Rndm4:Sq	89	BigBeat2:Dr
26	ChdAltB1:Sq	90	BigBeat3:Dr
27	ChdAltB2:Sq	91	BigBeat4:Dr
28	ChdAltB4:Sq	92	Rock1:Dr
29	ChdRndm1:Sq	93	Rock2:Dr
30	ChdRndm2:Sq	94	Rock3:Dr
31	ChdRndm4:Sq	95	BigBeat5:Dr
32	TechnoA:Ph	96	BigBeat6:Dr
33	TechnoB:Ph	97	BigBeat7:Dr
34	TechnoC:Ph	98	BigBeat8:Dr
35	DAHouse:Ph	99	BigBeat9:Dr
36	SyncopaA:Ph	100	BrkTrnce:Dr
37	SyncopaB:Ph	101	House1:Dr
38	SyncpEco:Ph	102	House2:Dr
39	TekEchoA:Ph	103	House3:Dr
40	TekEchoB:Ph	104	Garage:Dr
41	PulsLine:Ph	105	House4:Dr
42	SeqS&H1:Ph	106	House5:Dr
43	SeqS&H2:Ph	107	HipHop:Dr
44	CleanGt1:Ph	108	JazzHop:Dr
45	CleanGt2:Ph	109	Abstract:Dr
46	CleanGt3:Ph	110	LoBeat1:Dr
47	CleanGt4:Ph	111	LoBeat2:Dr
48	Pno16Bt:Ph	112	LoBeat3:Dr
49	PnoLatin:Ph	113	LoBeat4:Dr
50	CrvBass:Ph	114	LoBeat5:Dr
51	Ocean:Ph	115	LoBeat6:Dr
52	Orbit:Ph	116	Drm&Bs1:Dr
53	X-Sweep1:Ph	117	Drm&Bs2:Dr
54	X-Sweep2:Ph	118	Linear:Dr
55	X-Sweep3:Ph	119	08beat1:Dr
56	Lamb:Ph	120	08beat2:Dr
57	Thips:Ph	121	08beat3:Dr
58	Hardcore:Ph	122	16beat1:Dr
59	Harmo:Ph	123	16beat2:Dr
60	Ascorbic:Ph	124	1Bar:Dr
61	Doves:Ph	125	1BarRndm:Dr
62	Chodal:Ph	126	GateCut1:Ct
63	Simple:Ph	127	GateCut2:Ct
64	Waggle:Ph	128	GateCut3:Ct

Effect Type List

Effect Category	Effect Name	LCD	MIDI (HEX)		No.			
			MSB	LSB	REV	CHO	InsEF1	InsEF2
---	NO EFFECT	off	00	00	0	0		
---	THRU	Thru	00	00			0	0
REVERB								
REV	HALL 1	Hall1	01	00	1			1
REV	HALL 2	Hall2	01	01	2			2
REV	ROOM 1	Room1	01	10	3			3
REV	ROOM 2	Room2	01	11	4			4
REV	ROOM 3	Room3	01	12	5			5
REV	STAGE 1	Stage1	01	20	6			6
REV	STAGE 2	Stage2	01	21	7			7
REV	PLATE	Plate	01	30	8			8
REV	WHITE ROOM	WhiteRm	01	40	9			
REV	TUNNEL	Tunnel	01	41	10			
REV	BASEMENT	Basement	01	42	11			
REV	CANYON	Canyon	01	43	12			
DELAY								
DLY	DELAY L,C,R	DelayLCR	02	00				9
DLY	DELAY L,R	DelayLR	02	10		18		10
DLY	ECHO	Echo	02	20				11
DLY	CROSS DELAY	CrossDly	02	30				12
DLY	CONTROL DELAY1 (MONO)	CtrlDly1	02	40		19		13
DLY	CONTROL DELAY2 (STEREO)	CtrlDly2	02	48		20		14
DLY	TEMPO DELAY1 (MONO)	TempDly1	02	50		21		15
DLY	TEMPO DELAY2 (STEREO)	TempDly2	02	58		22		16
DLY	TEMPO CROSS DELAY	TempCDly	02	60		23		17
EARLY REFLECTION								
ER	EARLY REFLECTION 1	ER 1	03	00				18
ER	EARLY REFLECTION 2	ER 2	03	01				19
ER	GATE REVERB	GateRev	03	10				20
ER	REVERSE GATE	RvrsGate	03	20				21
KARAOKE								
KAR	KARAOKE 1	Karaoke1	04	00				22
KAR	KARAOKE 2	Karaoke2	04	01				23
KAR	KARAOKE 3	Karaoke3	04	02				24
CHORUS								
CHO	CHORUS 1	Chorus1	05	00		1	1	25
CHO	CHORUS 2	Chorus2	05	01		2	2	26
CHO	CHORUS 3	Chorus3	05	02		3	3	27
CHO	CHORUS 4	Chorus4	05	08		4	4	28
CHO	CHORUS 5	Chorus5	05	09		5	5	29
CHO	CELESTE 1	Celeste1	05	10		6	5	30
CHO	CELESTE 2	Celeste2	05	11		7	6	31
CHO	CELESTE 3	Celeste3	05	12		8	7	32
CHO	CELESTE 4	Celeste4	05	18		9	8	33
CHO	SYMPHONIC	Symphonc	05	20		10	34	
CHO	ENSEMBLE DETUNE	Ensemble	05	30		11	35	
FLANGER								
FLG	FLANGER 1	Flanger1	06	00		12	9	36
FLG	FLANGER 2	Flanger2	06	01		13	10	37
FLG	FLANGER 3	Flanger3	06	08		14	11	38
FLG	V-FLANGER	V-Flange	06	10				39
FLG	TEMPO FLANGER	TempFlng	06	50		15		40
PHASER								
PHA	PHASER 1	Phaser1	07	00		16	12	41
PHA	PHASER 2	Phaser2	07	08				42
PHA	TEMPO PHASER	TempPhas	07	50		17		43
MODULATION								
MOD	TREMOLO	Tremolo	08	00			13	44
MOD	AUTO PAN	AutoPan	08	10			14	45
MOD	ROTARY SPEAKER1	RotrySp1	08	50				46
MOD	DISTORTION+ROTARY SPEAKER1	Dt+RSp1	08	51				47
MOD	OVERDRIVE+ROTARY SPEAKER1	Od+RSp1	08	52				48
MOD	AMP SIM.+ROTARY SPEAKER1	Amp+RSp1	08	53				49
MOD	ROTARY SPEAKER2	RotrySp2	08	60				50
MOD	DISTORTION+ROTARY SPEAKER2	Dt+RSp2	08	61				51
MOD	OVERDRIVE+ROTARY SPEAKER2	Od+RSp2	08	62				52
MOD	AMP SIM.+ROTARY SPEAKER2	Amp+RSp2	08	63				53
MOD	ROTARY SPEAKER3	RotrySp3	08	70				54
MOD	ROTARY SPEAKER4	RotrySp4	08	71				55
DISTORTION								
DST	DISTORTION	Dist	09	00			15	56
DST	COMP DISTORTION	Comp+Dt	09	01				57
DST	V-DISTORTION	V-Dist	09	10				58
DST	OVER DRIVE	OverDrv	09	20			16	59
DST	AMP SIMULATOR	AmpSim	09	30			17	60
DST	DIST+DELAY	Dist+Dly	09	40				61
DST	OVERDRIVE+DELAY	Odrv+Dly	09	41				62
DYNAMIC								
DYN	COMPRESSOR1	Comp1	0A	00			18	63
DYN	NOISE GATE	NoisGate	0A	20			19	64
DYN	COMP+DIST+DELAY	CmpDtDly	0A	40				65
DYN	COMP+OVERDRIVE+DELAY	CmpOdDly	0A	41				66
PITCH CHANGE								
PCH	PITCH CHANGE 1	PchChng1	0B	00				67
PCH	PITCH CHANGE 2	PchChng2	0B	01				68
WAH								
WAH	AUTO WAH	AutoWah	0C	00			20	69
WAH	AUTO WAH + DIST	AWah+Dt	0C	01				70
WAH	AUTO WAH + OVERDRIVE	AWah+Od	0C	02				71
WAH	TOUCH WAH	TouchWah	0C	10			21	72
WAH	TOUCH WAH + DIST	TWah+Dt	0C	11				73
WAH	TOUCH WAH + OVERDRIVE	TWah+Od	0C	12				74
WAH	WAH+DIST+DELAY	WahDtDly	0C	40				75
WAH	WAH+OVERDRIVE+DELAY	WahOdDly	0C	41				76
LO-FI								
L-F	LO-FI	Lo-Fi	0D	00				77
L-F	LOW RESOLUTION	LowReso	0D	10				78
L-F	NOISY	Noisy	0D	20				79
L-F	ATTACK LOFI	AtkLoFi	0D	30				80
L-F	DIGITAL TURNTABLE	DTurnTbl	0D	50				81
TECH								
TEC	DIGITAL SCRATCH	DScratch	0E	00				82
TEC	AUTO SYNTH	AutoSyn	0E	10				83
TEC	TECH MODULATION	TechMod	0E	20				84
TEC	JUMP	Jump	0E	30				85
MISC								
MSC	3BAND EQ	3BandEQ	0F	00			22	86
MSC	2BAND EQ	2BandEQ	0F	01			23	87
MSC	HARMONIC ENHANCER	Enhancer	0F	10			24	88
MSC	VOICE CANCEL	VocCancel	0F	20				89
MSC	AMBIENCE	Ambience	0F	30				90
MSC	TALKING MODULATOR	TalkMod	0F	40				91
MSC	BEAT CHANGE	BeatChng	0F	50				92

Effect Parameter List

1. Reverb

[1] HALL1 ~ [8] PLATE

No.	Parameter	Value	LCD	MIDI Parameter Number	Controller
1	Reverb Time	0.3s~30.0s	RevTime	1	
2	Initial Delay	0.1ms~200.0ms	InitDly	3	
3	Reverb Delay	0.1ms~200.0ms	RevDly	6	
4	HPF Cutoff Frequency	20Hz~8.0kHz	HPF	4	○
5	LPF Cutoff Frequency	1.0kHz~20.0kHz	LPF	5	○
6	Diffusion	0~10	Diffuse	2	
7	Density	0~4	Density	7	
8	ER / Rev Balance	E63>R ~ E=R ~ E<R63	ER/Rev	8	○
9	Feedback High Damp	0.1~1.0	FBHIDmp	9	
10	Feedback Level	-63~+63	FBLevel	10	○

[9] WHITE ROOM ~ [12] CANYON

No.	Parameter	Value	LCD	MIDI Parameter Number	Controller
1	Reverb Time	0.3s~30.0s	RevTime	1	
2	Initial Delay	0.1ms~200.0ms	InitDly	3	
3	Reverb Delay	0.1ms~200.0ms	RevDly	10	
4	HPF Cutoff Frequency	20Hz~8.0kHz	HPF	4	○
5	LPF Cutoff Frequency	1.0kHz~20.0kHz	LPF	5	○
6	Diffusion	0~10	Diffuse	2	
7	Width	0.5m~30.2m	Width	6	
8	Height	0.5m~30.2m	Height	7	
9	Depth	0.5m~30.2m	Depth	8	
10	Wall Vary	0~30	Wall	9	

2. Chorus

[1] CHORUS1~[5] CHORUS5

The parameters marked with "⊗" can be controlled using the Chorus Control.

[6] CELESTE1~[9] CELESTE4

No.	Parameter	Value	LCD	MIDI Parameter Number	Controller
1	LFO Frequency	0.0Hz~39.70Hz	Speed	1	○
2	LFO Depth	0~127	Depth	2	⊗
3	EQ Low Frequency	32Hz~2.0kHz	L.Freq	5	○
4	EQ Low Gain	-12dB~+12dB	L.Gain	6	○
5	EQ High Frequency	500Hz~6.0kHz	H.Freq	7	○
6	EQ High Gain	-12dB~+12dB	H.Gain	8	○
7	Delay Offset	0.0ms~50.0ms	DlyOfst	4	
8	Feedback Level	-63~+63	FBLevel	3	○

[10] SYMPHONIC

No.	Parameter	Value	LCD	MIDI Parameter Number	Controller
1	LFO Frequency	0.0Hz~39.70Hz	Speed	1	○
2	LFO Depth	0~127	Depth	2	⊗
3	Delay Offset	0.0ms~50.0ms	DlyOfst	3	
4	EQ Low Frequency	32Hz~2.0kHz	L.Freq	4	○
5	EQ Low Gain	-12dB~+12dB	L.Gain	5	○
6	EQ High Frequency	500Hz~16.0kHz	H.Freq	6	○
7	EQ High Gain	-12dB~+12dB	H.Gain	7	○

[11] ENSEMBLE DETUNE

No.	Parameter	Value	LCD	MIDI Parameter Number	Controller
1	Detune	-50cent~+50cent	Detune	1	⊗
2	Initial Delay Lch	0.0ms~50.0ms	DelayL	2	
3	Initial Delay Rch	0.0ms~50.0ms	DelayR	3	

[12] FLANGER1 ~ [14] FLANGER3

No.	Parameter	Value	LCD	MIDI Parameter Number	Controller
1	LFO Frequency	0.0Hz~39.70Hz	Speed	1	⊗
2	LFO Depth	0~127	Depth	2	○
3	LFO Phase Difference	-180deg~+180deg	Phase	5	
4	EQ Low Frequency	32Hz~2.0kHz	L.Freq	6	○
5	EQ Low Gain	-12dB~+12dB	L.Gain	7	○
6	EQ High Frequency	500Hz~16.0kHz	H.Freq	8	○
7	EQ High Gain	-12dB~+12dB	H.Gain	9	○
8	Delay Offset	0.0ms~50.0ms	DlyOfst	4	
9	Feedback Level	-63~+63	FBLevel	3	○

[15] TEMPO FLANGER

No.	Parameter	Value	LCD	MIDI Parameter Number	Controller
1	LFO Frequency	5~21	Speed	1	○
2	LFO Depth	0~127	Depth	2	⊗
3	LFO Phase Difference	-180deg~+180deg	Phase	6	
4	LFO Phase Reset	off/free run, KeyOn/Reset, SEQ Start Reset	Reset	5	
5	EQ Low Frequency	32Hz~2.0kHz	L.Freq	7	○
6	EQ Low Gain	-12dB~+12dB	L.Gain	8	○
7	EQ High Frequency	500Hz~16.0kHz	H.Freq	9	○
8	EQ High Gain	-12dB~+12dB	H.Gain	10	○
9	Delay Offset	0.0ms~50.0ms	DlyOfst	4	
10	Feedback Level	-63~+63	FBLevel	3	○

[16] PHASER1

No.	Parameter	Value	LCD	MIDI Parameter Number	Controller
1	LFO Frequency	0.0Hz~39.70Hz	Speed	1	○
2	LFO Depth	0~127	Depth	2	○
3	Diffusion	mono/stereo	Diffuse	6	○
4	EQ Low Frequency	32Hz~2.0kHz	L.Freq	7	○
5	EQ Low Gain	-12dB~+12dB	L.Gain	8	○
6	EQ High Frequency	500Hz~16.0kHz	H.Freq	9	○
7	EQ High Gain	-12dB~+12dB	H.Gain	10	○
8	Stage	4, 5, 6	Stage	5	○
9	Phase Shift Offset	0~127	PhShift	3	
10	Feedback Level	-63~+63	FBLevel	4	⊗

[17] TEMPO PHASER

No.	Parameter	Value	LCD	MIDI Parameter Number	Controller
1	LFO Frequency	5~21	Speed	1	○
2	LFO Depth	0~127	Depth	2	⊗
3	LFO Phase Reset	off/free run, KeyOn/Reset, SEQ Start Reset	PhaseReset	6	
4	EQ Low Frequency	32Hz~2.0kHz	L.Freq	7	○
5	EQ Low Gain	-12dB~+12dB	L.Gain	8	○
6	EQ High Frequency	500Hz~16.0kHz	H.Freq	9	○
7	EQ High Gain	-12dB~+12dB	H.Gain	10	○
8	Stage	4, 5, 6	Stage	5	○
9	Phase Shift Offset	0~127	PhShift	3	
10	Feedback Level	-63~+63	FBLevel	4	○

[18] DELAY L,R(stereo)

No.	Parameter	Value	LCD	MIDI Parameter Number	Controller
1	Delay Time L	0.1ms~740.0ms	TimeL	1	
2	Delay Time R	0.1ms~740.0ms	TimeR	2	
3	Feedback Time 1	0.1ms~740.0ms	FBTime1	3	
4	Feedback Time 2	0.1ms~740.0ms	FBTime2	4	
5	Feedback Level	-63~+63	FBLevel	5	⊗
6	Feedback High Damp	0.1~1.0	FBHiDmp	6	○
7	EQ Low Frequency	32Hz~2.0kHz	L.Freq	7	○
8	EQ Low Gain	-12dB~+12dB	L.Gain	8	○
9	EQ High Frequency	500Hz~16.0kHz	H.Freq	9	○
10	EQ High Gain	-12dB~+12dB	H.Gain	10	○

[19] CONTROL DELAY1(mono)

No.	Parameter	Value	LCD	MIDI Parameter Number	Controller
1	Delay Time	0.1ms~1480.0ms	Time	1	⊗
2	Delay Transition Rate	1~48	Trnsitn	2	○
3	Feedback Level	-63~+63	FBLevel	3	○
4	Feedback High Damp	0.1~1.0	FBHiDmp	4	○
5	EQ Low Frequency	32Hz~2.0kHz	L.Freq	5	○
6	EQ Low Gain	-12dB~+12dB	L.Gain	6	○
7	EQ High Frequency	500Hz~16.0kHz	H.Freq	7	○
8	EQ High Gain	-12dB~+12dB	H.Gain	8	○

[20] CONTROL DELAY2(stereo)

No.	Parameter	Value	LCD	MIDI Parameter Number	Controller
1	Delay Time	0.1ms~740.0ms	Time	1	⊗
2	Delay Transition Rate	1~48	Trnsitn	2	○
3	Feedback Level	-63~+63	FBLevel	3	○
4	Feedback High Damp	0.1~1.0	FBHiDmp	4	○
5	EQ Low Frequency	32Hz~2.0kHz	L.Freq	5	○
6	EQ Low Gain	-12dB~+12dB	L.Gain	6	○
7	EQ High Frequency	500Hz~16.0kHz	H.Freq	7	○
8	EQ High Gain	-12dB~+12dB	H.Gain	8	○

[21] TEMPO DELAY1(mono)

No.	Parameter	Value	LCD	MIDI Parameter Number	Controller
1	Delay Time	2~14	Time	1	
2	Lag	-63ms~+63ms	Lag	5	
3	L/R Diffusion	-63ms~+63ms	Diffuse	4	
4	Feedback Level	-63~+63	FBLevel	2	⊗
5	Feedback High Damp	0.1~1.0	FBHiDmp	3	○
6	EQ Low Frequency	32Hz~2.0kHz	L.Freq	6	○
7	EQ Low Gain	-12dB~+12dB	L.Gain	7	○
8	EQ High Frequency	500Hz~16.0kHz	H.Freq	8	○
9	EQ High Gain	-12dB~+12dB	H.Gain	9	○

[22] TEMPO DELAY2(stereo)

No.	Parameter	Value	LCD	MIDI Parameter Number	Controller
1	Delay Time	2~14	Time	1	
2	Lag	-63ms~+63ms	Lag	5	
3	L/R Diffusion	-63ms~+63ms	Diffuse	4	
4	Feedback Level	-63~+63	FBLevel	2	⊗
5	Feedback High Damp	0.1~1.0	FBHiDmp	3	○
6	EQ Low Frequency	32Hz~2.0kHz	L.Freq	6	○
7	EQ Low Gain	-12dB~+12dB	L.Gain	7	○
8	EQ High Frequency	500Hz~16.0kHz	H.Freq	8	○
9	EQ High Gain	-12dB~+12dB	H.Gain	9	○

[23] TEMPO CROSS DELAY

No.	Parameter	Value	LCD	MIDI Parameter Number	Controller
1	Delay Time L>R	2~14	TimeL>R	1	
2	Delay Time R>L	2~14	TimeR>L	2	
3	Input Select	L, R, L&R	Input	5	
4	Lag	-63ms~+63ms	Lag	6	
5	Feedback Level	-63~+63	FBLevel	3	⊗
6	Feedback High Damp	0.1~1.0	FBHiDmp	4	○
7	EQ Low Frequency	32Hz~2.0kHz	L.Freq	7	○
8	EQ Low Gain	-12dB~+12dB	L.Gain	8	○
9	EQ High Frequency	500Hz~16.0kHz	H.Freq	9	○
10	EQ High Gain	-12dB~+12dB	H.Gain	10	○

3. Insertion Effect 1
[0] THRU (None)

[1]~[4] CHORUS1~4
[5]~[8] CELESTE1~4

No.	Parameter	Value	LCD	MIDI Parameter Number	Controller
1	LFO Frequency	0.0Hz~39.70Hz	Speed	1	○
2	LFO Depth	0~127	Depth	2	○
3	Input Mode	mono/stereo	Input	9	
4	EQ Low Frequency	32Hz~2.0kHz	L.Freq	5	○
5	EQ Low Gain	-12dB~+12dB	L.Gain	6	○
6	EQ High Frequency	500Hz~16.0kHz	H.Freq	7	○
7	EQ High Gain	-12dB~+12dB	H.Gain	8	○
8	Delay Offset	0.0ms~50.0ms	DlyOfst	4	
9	Feedback Level	-63~+63	FBLevel	3	○
10	Dry / Wet Balance	D63>W -D=W -D<W63	Dry/Wet	10	○

[9]~[11] FLANGER1~3

No.	Parameter	Value	LCD	MIDI Parameter Number	Controller
1	LFO Frequency	0.0Hz~39.70Hz	Speed	1	○
2	LFO Depth	0~127	Depth	2	○
3	LFO Phase Difference	-180deg~+180deg	Phase	9	
4	EQ Low Frequency	32Hz~2.0kHz	L.Freq	5	○
5	EQ Low Gain	-12dB~+12dB	L.Gain	6	○
6	EQ High Frequency	500Hz~16.0kHz	H.Freq	7	○
7	EQ High Gain	-12dB~+12dB	H.Gain	8	○
8	Delay Offset	0.0ms~50.0ms	DlyOfst	4	
9	Feedback Level	-63~+63	FBLevel	3	○
10	Dry / Wet Balance	D63>W - D=W - D<W63	Dry/Wet	10	○

[12] PHASER1

No.	Parameter	Value	LCD	MIDI Parameter Number	Controller
1	LFO Frequency	0.0Hz~39.70Hz	Speed	1	○
2	LFO Depth	0~127	Depth	2	○
3	EQ Low Frequency	32Hz~2.0kHz	L.Freq	6	○
4	EQ Low Gain	-12dB~+12dB	L.Gain	7	○
5	EQ High Frequency	500Hz~16.0kHz	H.Freq	8	○
6	EQ High Gain	-12dB~+12dB	H.Gain	9	○
7	Stage	4, 5, 6	Stage	5	○
8	Phase Shift Offset	0~127	PhShift	3	○
9	Feedback Level	-63~+63	FBLevel	4	○
10	Dry / Wet Balance	D63>W ~ D=W ~ D<W63	Dry/Wet	10	○

[13] TREMOLO

No.	Parameter	Value	LCD	MIDI Parameter Number	Controller
1	LFO Frequency	0.0Hz~39.70Hz	Speed	1	○
2	AM Depth	0~127	AMDepth	2	○
3	PM Depth	0~127	PMDepth	3	○
4	LFO Phase Difference	-180deg~+180deg	Phase	4	○
5	EQ Low Frequency	32Hz~2.0kHz	L.Freq	5	○
6	EQ Low Gain	-12dB~+12dB	L.Gain	6	○
7	EQ High Frequency	500Hz~16.0kHz	H.Freq	7	○
8	EQ High Gain	-12dB~+12dB	H.Gain	8	○
9	Input Mode	mono/stereo	Input	9	○

[14] AUTO PAN

No.	Parameter	Value	LCD	MIDI Parameter Number	Controller
1	LFO Frequency	0.0Hz~39.70Hz	Speed	1	○
2	L/R Depth	0~127	L/RDpth	2	○
3	F/R Depth	0~127	F/RDpth	3	○
4	PAN Direction	L<R, L>R, L<R, L>R, L<R, L>R, L<R, L>R (0-5)	Directn	4	○
5	EQ Low Frequency	32Hz~2.0kHz	L.Freq	5	○
6	EQ Low Gain	-12dB~+12dB	L.Gain	6	○
7	EQ High Frequency	500Hz~16.0kHz	H.Freq	7	○
8	EQ High Gain	-12dB~+12dB	H.Gain	8	○

[15] DISTORTION

[16] OVERDRIVE

No.	Parameter	Value	LCD	MIDI Parameter Number	Controller
1	Drive	0~127	Drive	1	○
2	Edge	0~127	Edge	8	○
3	Output Level	0~127	OutLvl	9	○
4	EQ Low Frequency	32Hz~2.0kHz	L.Freq	2	○
5	EQ Low Gain	-12dB~+12dB	L.Gain	3	○
6	LPF Cutoff Frequency	1.0kHz~20.0kHz	LPF	7	○
7	EQ Mid Frequency	100Hz~10.0kHz	M.Freq	4	○
8	EQ Mid Gain	-12dB~+12dB	M.Gain	5	○
9	EQ Mid Width	0.1~12.0	M.Width	6	○
10	Dry / Wet Balance	D63>W ~ D=W ~ D<W63	Dry/Wet	10	○

[17] AMP SIMULATOR

No.	Parameter	Value	LCD	MIDI Parameter Number	Controller
1	AMP Type	off, stack, combo, tube	AmpType	2	○
2	Drive	0~127	Drive	1	○
3	Edge	0~127	Edge	4	○
4	Output Level	0~127	OutLvl	5	○
5	LPF Cutoff Frequency	1.0kHz~20.0kHz	LPF	3	○
6	Dry / Wet Balance	D63>W ~ D=W ~ D<W63	Dry/Wet	6	○

[18] COMPRESSOR

No.	Parameter	Value	LCD	MIDI Parameter Number	Controller
1	Attack	1ms~40ms	Attack	1	○
2	Release	10ms~680ms	Release	2	○
3	Threshold	-48dB~-6dB	Thrshld	3	○
4	Ratio	1~20.0	Ratio	4	○
5	Output Level	0~127	OutLvl	5	○

[19] NOISE GATE

No.	Parameter	Value	LCD	MIDI Parameter Number	Controller
1	Attack	1ms~40ms	Attack	1	○
2	Release	10ms~680ms	Release	2	○
3	Threshold	-72dB~-30dB	Thrshld	3	○
4	Output Level	0~127	Out Lvl	4	○

[20] AUTO WAH

No.	Parameter	Value	LCD	MIDI Parameter Number	Controller
1	LFO Frequency	0.0Hz~39.70Hz	Speed	1	○
2	LFO Depth	0~127	Depth	2	○
3	Cutoff Frequency Offset	0~127	Cutoff	3	○
4	Resonance	1~12.0	Reso	4	○
5	EQ Low Frequency	32Hz~2.0kHz	L.Freq	5	○
6	EQ Low Gain	-12dB~+12dB	L.Gain	6	○
7	EQ High Frequency	500Hz~16.0kHz	H.Freq	7	○
8	EQ High Gain	-12dB~+12dB	H.Gain	8	○
9	Dry / Wet Balance	D63>W ~ D=W ~ D<W63	Dry/Wet	9	○

[21] TOUCH WAH

No.	Parameter	Value	LCD	MIDI Parameter Number	Controller
1	Sensitive	0~127	Sens	1	○
2	Cutoff Frequency Offset	0~127	Cutoff	2	○
3	Resonance	1~12.0	Reso	3	○
4	EQ Low Frequency	32Hz~2.0kHz	L.Freq	4	○
5	EQ Low Gain	-12dB~+12dB	L.Gain	5	○
6	EQ High Frequency	500Hz~16.0kHz	H.Freq	6	○
7	EQ High Gain	-12dB~+12dB	H.Gain	7	○
8	Dry / Wet Balance	D63>W ~ D=W ~ D<W63	Dry/Wet	8	○

[22] 2BAND EQ

No.	Parameter	Value	LCD	MIDI Parameter Number	Controller
1	EQ Low Frequency	32Hz~2.0kHz	L.Freq	1	○
2	EQ Low Gain	-12dB~+12dB	L.Gain	2	○
3	EQ High Frequency	500Hz~16.0kHz	H.Freq	3	○
4	EQ High Gain	-12dB~+12dB	H.Gain	4	○

[23] 3BAND EQ

No.	Parameter	Value	LCD	MIDI Parameter Number	Controller
1	EQ Low Frequency	50Hz~2.0kHz	L.Freq	1	○
2	EQ Low Gain	-12dB~+12dB	L.Gain	2	○
3	EQ High Frequency	500Hz~16.0kHz	H.Freq	6	○
4	EQ High Gain	-12dB~+12dB	H.Gain	7	○
5	EQ Mid Frequency	100Hz~10.0kHz	M.Freq	3	○
6	EQ Mid Gain	-12dB~+12dB	M.Gain	4	○
7	EQ Mid Width	0.1~12.0	M.Width	5	○
8	Input Mode	mono/stereo	Input	8	○

[24] HARMONIC ENHANCER

No.	Parameter	Value	LCD	MIDI Parameter Number	Controller
1	HPF Cutoff Frequency	500Hz~+16.0kHz	HPF	1	○
2	Drive	0~127	Drive	2	○
3	Mix Level	0~127	Mix Lvl	3	○

4. Insertion Effect 2

[0] THRU (None)

[1] HALL1 ~ [8] PLATE

No.	Parameter	Value	LCD	MIDI Parameter Number	Controller
1	Reverb Time	0.3s~30.0s	RevTime	1	○
2	Initial Delay	0.1ms~99.3ms	InitDly	3	○
3	Reverb Delay	0.1ms~99.3ms	RevDly	11	○
4	Dry / Wet Balance	D63>W ~ D=W ~ D<W63	Dry/Wet	10	○
5	HPF Cutoff Frequency	20Hz~8.0kHz	HPF	4	○
6	LPF Cutoff Frequency	1.0kHz~20.0kHz	LPF	5	○
7	Diffusion	0~10	Diffuse	2	○
8	Density	0~4	Density	12	○
9	ER / Rev Balance	E63>R ~ E=R ~ E<R63	ER/Rev	13	○
10	Feedback Level	-63~+63	FBLevel	15	○
11	Feedback High Damp	0.1~1.0	FBHiDmp	14	○

[9] DELAY L,C,R

No.	Parameter	Value	LCD	MIDI Parameter Number	Controller
1	Delay Time L	0.1ms~1486.0ms	TimeL	1	
2	Delay Time R	0.1ms~1486.0ms	TimeR	2	
3	Delay Time C	0.1ms~1486.0ms	TimeC	3	
4	Dry / Wet Balance	D63>W ~ D=W ~ D<W63	Dry/Wet	10	○
5	Delay Level C	0~127	LevelC	6	○
6	Feedback Time	0.1ms~1486.0ms	FBTime	4	
7	Feedback Level	-63~+63	FBLevel	5	○
8	Feedback High Damp	0.1~1.0	FBHiDmp	7	○
9	EQ Low Frequency	32Hz~2.0kHz	L.Freq	13	○
10	EQ Low Gain	-12dB~+12dB	L.Gain	14	○
11	EQ High Frequency	500Hz~16.0kHz	H.Freq	15	○
12	EQ High Gain	-12dB~+12dB	H.Gain	16	○

[10] DELAY L,R

No.	Parameter	Value	LCD	MIDI Parameter Number	Controller
1	Delay Time L	0.1ms~1486.0ms	TimeL	1	
2	Delay Time R	0.1ms~1486.0ms	TimeR	2	
3	Dry / Wet Balance	D63>W ~ D=W ~ D<W63	Dry/Wet	10	○
4	Feedback Time 1	0.1ms~1486.0ms	FBTime1	3	
5	Feedback Time 2	0.1ms~1486.0ms	FBTime2	4	
6	Feedback Level	-63~+63	FBLevel	5	○
7	Feedback High Damp	0.1~1.0	FBHiDmp	6	○
8	EQ Low Frequency	32Hz~2.0kHz	L.Freq	13	○
9	EQ Low Gain	-12dB~+12dB	L.Gain	14	○
10	EQ High Frequency	500Hz~16.0kHz	H.Freq	15	○
11	EQ High Gain	-12dB~+12dB	H.Gain	16	○

[11] ECHO

No.	Parameter	Value	LCD	MIDI Parameter Number	Controller
1	Delay Time L1	0.1ms~743.0ms	TimeL1	1	
2	Delay Time R1	0.1ms~743.0ms	TimeR1	3	
3	Dry / Wet Balance	D63>W ~ D=W ~ D<W63	Dry/Wet	10	○
4	Feedback Level L	-63~+63	FBLevelL	2	○
5	Feedback Level R	-63~+63	FBLevelR	4	○
6	Feedback High Damp	0.1~1.0	FBHiDmp	5	○
7	Delay Time L2	0.1ms~743.0ms	TimeL2	6	
8	Delay Time R2	0.1ms~743.0ms	TimeR2	7	
9	Delay Level	0~127	Level2	8	○
10	EQ Low Frequency	32Hz~2.0kHz	L.Freq	13	○
11	EQ Low Gain	-12dB~+12dB	L.Gain	14	○
12	EQ High Frequency	500Hz~16.0kHz	H.Freq	15	○
13	EQ High Gain	-12dB~+12dB	H.Gain	16	○

[12] CROSS DELAY

No.	Parameter	Value	LCD	MIDI Parameter Number	Controller
1	Delay Time L>R	0.1ms~743.0ms	TimeL>R	1	
2	Delay Time R>L	0.1ms~743.0ms	TimeR>L	2	
3	Input Select	L, R, L&R	Input	4	
4	Dry / Wet Balance	D63>W ~ D=W ~ D<W63	Dry/Wet	10	○
5	Feedback Level	-63~+63	FBLevel	3	○
6	Feedback High Damp	0.1~1.0	FBHiDmp	5	○
7	EQ Low Frequency	32Hz~2.0kHz	L.Freq	13	○
8	EQ Low Gain	-12dB~+12dB	L.Gain	14	○
9	EQ High Frequency	500Hz~16.0kHz	H.Freq	15	○
10	EQ High Gain	-12dB~+12dB	H.Gain	16	○

[13] CONTROL DELAY1(mono)

No.	Parameter	Value	LCD	MIDI Parameter Number	Controller
1	Delay Time	0.1ms~1486.0ms	Time	1	○
2	Delay Transition Rate	1~48	Trnsitn	2	○
3	Dry / Wet Balance	D63>W ~ D=W ~ D<W63	Dry/Wet	10	○
4	Control Type	normal, scratch	CtrType	11	○
5	Feedback Level	-63~+63	FBLevel	3	○
6	Feedback High Damp	0.1~1.0	FBHiDmp	4	○
7	EQ Low Frequency	32Hz~2.0kHz	L.Freq	6	○
8	EQ Low Gain	-12dB~+12dB	L.Gain	7	○
9	EQ High Frequency	500Hz~16.0kHz	H.Freq	8	○
10	EQ High Gain	-12dB~+12dB	H.Gain	9	○

[14] CONTROL DELAY2(stereo)

No.	Parameter	Value	LCD	MIDI Parameter Number	Controller
1	Delay Time	0.1ms~743.0ms	Time	1	○
2	Delay Transition Rate	1~48	Trnsitn	2	○
3	Dry / Wet Balance	D63>W ~ D=W ~ D<W63	Dry/Wet	10	○
4	Control Type	normal, scratch	CtrType	11	○
5	Feedback Level	-63~+63	FBLevel	3	○
6	Feedback High Damp	0.1~1.0	FBHiDmp	4	○
7	EQ Low Frequency	32Hz~2.0kHz	L.Freq	6	○
8	EQ Low Gain	-12dB~+12dB	L.Gain	7	○
9	EQ High Frequency	500Hz~16.0kHz	H.Freq	8	○
10	EQ High Gain	-12dB~+12dB	H.Gain	9	○

[15] TEMPO DELAY1(mono)

No.	Parameter	Value	LCD	MIDI Parameter Number	Controller
1	Delay Time	2~14	Time	1	
2	Dry / Wet Balance	D63>W ~ D=W ~ D<W63	Dry/Wet	10	○
3	Lag	-63ms~+63ms	Lag	6	
4	L/R Diffusion	-63ms~+63ms	Diffuse	5	
5	Feedback Level	-63~+63	FBLevel	3	○
6	Feedback High Damp	0.1~1.0	FBHiDmp	4	○
7	EQ Low Frequency	32Hz~2.0kHz	L.Freq	13	○
8	EQ Low Gain	-12dB~+12dB	L.Gain	14	○
9	EQ High Frequency	500Hz~16.0kHz	H.Freq	15	○
10	EQ High Gain	-12dB~+12dB	H.Gain	16	○

[16] TEMPO DELAY2(stereo)

No.	Parameter	Value	LCD	MIDI Parameter Number	Controller
1	Delay Time	2~14	Time	1	
2	Dry / Wet Balance	D63>W ~ D=W ~ D<W63	Dry/Wet	10	○
3	Lag	-63ms~+63ms	Lag	6	
4	L/R Diffusion	-63ms~+63ms	Diffuse	5	
5	Feedback Level	-63~+63	FBLevel	3	○
6	Feedback High Damp	0.1~1.0	FBHiDmp	4	○
7	EQ Low Frequency	32Hz~2.0kHz	L.Freq	13	○
8	EQ Low Gain	-12dB~+12dB	L.Gain	14	○
9	EQ High Frequency	500Hz~16.0kHz	H.Freq	15	○
10	EQ High Gain	-12dB~+12dB	H.Gain	16	○

[17] TEMPO CROSS DELAY

No.	Parameter	Value	LCD	MIDI Parameter Number	Controller
1	Delay Time L>R	2~14	TimeL>R	1	
2	Delay Time R>L	2~14	TimeR>L	2	
3	Input Select	L, R, L&R	Input	6	
4	Dry / Wet Balance	D63>W ~ D=W ~ D<W63	Dry/Wet	10	○
5	Lag	-63ms~ +63ms	Lag	8	
6	Feedback Level	-63~+63	FBLevel	4	○
7	Feedback High Damp	0.1~1.0	FBHiDmp	5	○
8	EQ Low Frequency	32Hz~2.0kHz	L.Freq	13	○
9	EQ Low Gain	-12dB~+12dB	L.Gain	14	○
10	EQ High Frequency	500Hz~16.0kHz	H.Freq	15	○
11	EQ High Gain	-12dB~+12dB	H.Gain	16	○

[18]-[19] EARLY REF1~2

No.	Parameter	Value	LCD	MIDI Parameter Number	Controller
1	Type	S-hall, L-hall, random, reverse, plate, spring	Type	1	
2	Room Size	0.1~20.0	Size	2	
3	Dry / Wet Balance	D63>W ~ D=W ~ D<W63	Dry/Wet	10	○
4	Diffusion	0 ~ 10	Diffuse	3	
5	Initial Delay	0.1ms~200.0ms	InitDly	4	
6	Liveness	0 ~ 10	Livenss	11	
7	Density	0 ~ 3	Density	12	
8	HPF Cutoff Frequency	20Hz~8.0kHz	HPF	6	○
9	LPF Cutoff Frequency	1.0kHz~20.0kHz	LPF	7	○
10	Feedback Level	-63~+63	FBLevel	5	○
11	Feedback High Damp	0.1~1.0	FBHiDmp	13	

[20] GATE REVERB
[21] REVERSE GATE

No.	Parameter	Value	LCD	MIDI Parameter Number	Controller
1	Type	Type-A, Type-B	Type	1	
2	Room Size	0.1~20.0	Size	2	
3	Dry / Wet Balance	D63>W ~ D=W ~ D<W63	Dry/Wet	10	○
4	Diffusion	0 ~ 10	Diffuse	3	
5	Initial Delay	0.1ms~200.0ms	InitDly	4	
6	Liveness	0 ~ 10	Livenss	11	
7	Density	0 ~ 3	Density	12	
8	HPF Cutoff Frequency	20Hz~8.0kHz	HPF	6	○
9	LPF Cutoff Frequency	1.0kHz~20.0kHz	LPF	7	○
10	Feedback Level	-63~+63	FBLevel	5	○
11	Feedback High Damp	0.1~1.0	FBHiDmp	13	

[22]-[24] KARAOKE1-3

No.	Parameter	Value	LCD	MIDI Parameter Number	Controller
1	Delay Time	0.1ms~400.0ms	DlyTime	1	
2	Feedback Level	-63~+63	FBLevel	2	○
3	Dry / Wet Balance	D63>W ~ D=W ~ D<W63	Dry/Wet	10	○
4	HPF Cutoff Frequency	20Hz~8.0kHz	HPF	3	○
5	LPF Cutoff Frequency	1.0kHz~20.0kHz	LPF	4	○

[25]-[29] CHORUS1-5
[30]-[33] CELESTE1-4

No.	Parameter	Value	LCD	MIDI Parameter Number	Controller
1	LFO Frequency	0.0Hz~39.70Hz	Speed	1	○
2	LFO Depth	0~127	Depth	2	○
3	Input Mode	mono/stereo	Input	15	
4	EQ Low Frequency	32Hz~2.0kHz	L.Freq	6	○
5	EQ Low Gain	-12dB~+12dB	L.Gain	7	○
6	EQ High Frequency	500Hz~16.0kHz	H.Freq	8	○
7	EQ High Gain	-12dB~+12dB	H.Gain	9	○
8	EQ Mid Frequency	100Hz~10.0kHz	M.Freq	11	○
9	EQ Mid Gain	-12dB~+12dB	M.Gain	12	○
10	EQ Mid Width	0.1~12.0	M.Width	13	○
11	Delay Offset	0.0ms~50.0ms	DlyOfst	4	
12	Feedback Leve	-63~+63	FBLevel	3	○
13	Dry / Wet Balance	D63>W ~ D=W ~ D<W63	Dry/Wet	10	○

[34] SYMPHONIC

No.	Parameter	Value	LCD	MIDI Parameter Number	Controller
1	LFO Frequency	0.0Hz~39.70Hz	Speed	1	○
2	LFO Depth	0~127	Depth	2	○
3	Delay Offset	0.0ms~50.0ms	DlyOfst	4	
4	EQ Low Frequency	32Hz~2.0kHz	L.Freq	6	○
5	EQ Low Gain	-12dB~+12dB	L.Gain	7	○
6	EQ High Frequency	500Hz~16.0kHz	H.Freq	8	○
7	EQ High Gain	-12dB~+12dB	H.Gain	9	○
8	EQ Mid Frequency	100Hz~10.0kHz	M.Freq	11	○
9	EQ Mid Gain	-12dB~+12dB	M.Gain	12	○
10	EQ Mid Width	0.1~12.0	M.Width	13	○
11	Dry / Wet Balance	D63>W ~ D=W ~ D<W63	Dry/Wet	10	○

[35] ENSEMBLE DETUNE

No.	Parameter	Value	LCD	MIDI Parameter Number	Controller
1	Detune	-50cent~+50cent	Detune	1	
2	Initial Delay Lch	0.0ms~50.0ms	DelayL	2	
3	Initial Delay Rch	0.0ms~50.0ms	DelayR	3	
4	Dry / Wet Balance	D63>W ~ D=W ~ D<W63	Dry/Wet	10	○
5	EQ Low Frequency	32Hz~2.0kHz	L.Freq	11	○
6	EQ Low Gain	-12dB~+12dB	L.Gain	12	○
7	EQ High Frequency	500Hz~16.0kHz	H.Freq	13	○
8	EQ High Gain	-12dB~+12dB	H.Gain	14	○

[36]-[38] FLANGER1-3

No.	Parameter	Value	LCD	MIDI Parameter Number	Controller
1	LFO Frequency	0.0Hz~39.70Hz	Speed	1	○
2	LFO Depth	0~127	Depth	2	○
3	LFO Phase Difference	-180deg~+180deg	Phase	14	
4	EQ Low Frequency	32Hz~2.0kHz	L.Freq	6	○
5	EQ Low Gain	-12dB~+12dB	L.Gain	7	○
6	EQ High Frequency	500Hz~16.0kHz	H.Freq	8	○
7	EQ High Gain	-12dB~+12dB	H.Gain	9	○
8	EQ Mid Frequency	100Hz~10.0kHz	M.Freq	11	○
9	EQ Mid Gain	-12dB~+12dB	M.Gain	12	○
10	EQ Mid Width	0.1~12.0	M.Width	13	○
11	Delay Offset	0.0ms~50.0ms	DlyOfst	4	
12	Feedback Leve	-63~+63	FBLevel	3	○
13	Dry / Wet Balance	D63>W ~ D=W ~ D<W63	Dry/Wet	10	○

[39] V-FLANGER

No.	Parameter	Value	LCD	MIDI Parameter Number	Controller
1	LFO Frequency	0.0Hz~39.70Hz	Speed	1	○
2	LFO Depth	0~127	Depth	2	○
3	LFO Wave	Triangle, Sine, Random	Wave	3	
4	Modulation Phase	-180~+180	Phase	5	
5	EQ Low Frequency	32Hz~2.0kHz	L.Freq	6	○
6	EQ Low Gain	-12dB~+12dB	L.Gain	7	○
7	EQ High Frequency	500Hz~16.0kHz	H.Freq	8	○
8	EQ High Gain	-12dB~+12dB	H.Gain	9	○
9	EQ Mid Frequency	100Hz~10.0kHz	M.Freq	11	○
10	EQ Mid Gain	-12dB~+12dB	M.Gain	12	○
11	EQ Mid Width	0.1~12.0	M.Width	13	○
12	Analog Feel	0~10	Analog	16	○
13	Feedback Gain	-100~+100%	FBLevel	14	○
14	Feedback High Damp	0.1~1.0	FBHiDmp	15	○
15	Delay Offset	0.09~36.21ms	DlyOfst	4	
16	Dry / Wet Balance	D63>W ~ D=W ~ D<W63	Dry/Wet	10	○

[40] TEMPO FLANGER

No.	Parameter	Value	LCD	MIDI Parameter Number	Controller
1	LFO Frequency	5~21	Speed	1	○
2	LFO Depth	0~127	Depth	2	○
3	LFO Phase Difference	-180deg~+180deg	Phase	14	
4	LFO Phase Reset	off/free run/, KeyOn/Reset, SEQ Start/Reset	Reset	5	
5	EQ Low Frequency	32Hz~2.0kHz	L.Freq	6	○
6	EQ Low Gain	-12dB~+12dB	L.Gain	7	○
7	EQ High Frequency	500Hz~16.0kHz	H.Freq	8	○
8	EQ High Gain	-12dB~+12dB	H.Gain	9	○
9	EQ Mid Frequency	100Hz~10.0kHz	M.Freq	11	○
10	EQ Mid Gain	-12dB~+12dB	M.Gain	12	○
11	EQ Mid Width	0.1~12.0	M.Width	13	○
12	Delay Offset	0.0ms~50.0ms	DlyOfst	4	
13	Feedback Level	-63~+63	FBLevel	3	○
14	Dry / Wet Balance	D63>W ~ D=W ~ D<W63	Dry/Wet	10	○

[41] PHASER1

No.	Parameter	Value	LCD	MIDI Parameter Number	Controller
1	LFO Frequency	0.0Hz~39.70Hz	Speed	1	○
2	LFO Depth	0~127	Depth	2	○
3	Diffusion	mono/stereo	Diffuse	12	
4	EQ Low Frequency	32Hz~2.0kHz	L.Freq	6	○
5	EQ Low Gain	-12dB~+12dB	L.Gain	7	○
6	EQ High Frequency	500Hz~16.0kHz	H.Freq	8	○
7	EQ High Gain	-12dB~+12dB	H.Gain	9	○
8	Stage	4, 5, 6, 7, 8, 9, 10, 11, 12	Stage	11	○
9	Phase Shift Offset	0~127	PhShift	3	
10	Feedback Level	-63~+63	FBLevel	4	○
11	Dry / Wet Balance	D63>W ~ D=W ~ D<W63	Dry/Wet	10	○

[42] PHASER2

No.	Parameter	Value	LCD	MIDI Parameter Number	Controller
1	LFO Frequency	0.0Hz~39.70Hz	Speed	1	○
2	LFO Depth	0~127	Depth	2	○
3	LFO Phase Difference	-180deg~+180deg	Phase	13	○
4	EQ Low Frequency	32Hz~2.0kHz	L.Freq	6	○
5	EQ Low Gain	-12dB~+12dB	L.Gain	7	○
6	EQ High Frequency	500Hz~16.0kHz	H.Freq	8	○
7	EQ High Gain	-12dB~+12dB	H.Gain	9	○
8	Stage	3, 4, 5, 6	Stage	11	○
9	Phase Shift Offset	0~127	PhShift	3	○
10	Feedback Level	-63~+63	FBLevel	4	○
11	Dry / Wet Balance	D63>W ~ D=W ~ D<W63	Dry/Wet	10	○

[43] TEMPO PHASER

No.	Parameter	Value	LCD	MIDI Parameter Number	Controller
1	LFO Frequency	5~21	Speed	1	○
2	LFO Depth	0~127	Depth	2	○
3	LFO Phase Difference	-180deg~+180deg	Phase	13	○
4	LFO Phase Reset	off/free run, KeyOn/Reset, SEQ Start/Reset	Reset	5	○
5	EQ Low Frequency	32Hz~2.0kHz	L.Freq	6	○
6	EQ Low Gain	-12dB~+12dB	L.Gain	7	○
7	EQ High Frequency	500Hz~16.0kHz	H.Freq	8	○
8	EQ High Gain	-12dB~+12dB	H.Gain	9	○
9	Stage	3, 4, 5, 6	Stage	11	○
10	Phase Shift Offset	0~127	PhShift	3	○
11	Feedback Level	-63~+63	FBLevel	4	○
12	Dry / Wet Balance	D63>W ~ D=W ~ D<W63	Dry/Wet	10	○

[44] TREMOLO

No.	Parameter	Value	LCD	MIDI Parameter Number	Controller
1	LFO Frequency	0.0Hz~39.70Hz	Speed	1	○
2	AM Depth	0~127	AMDepth	2	○
3	PM Depth	0~127	PMDepth	3	○
4	LFO Phase Difference	-180deg~+180deg	Phase	14	○
5	EQ Low Frequency	32Hz~2.0kHz	L.Freq	6	○
6	EQ Low Gain	-12dB~+12dB	L.Gain	7	○
7	EQ High Frequency	500Hz~16.0kHz	H.Freq	8	○
8	EQ High Gain	-12dB~+12dB	H.Gain	9	○
9	EQ Mid Frequency	100Hz~10.0kHz	M.Freq	11	○
10	EQ Mid Gain	-12dB~+12dB	M.Gain	12	○
11	EQ Mid Width	0.1~12.0	M.Width	13	○
12	Input Mode	mono/stereo	Input	15	○

[45] AUTO PAN

No.	Parameter	Value	LCD	MIDI Parameter Number	Controller
1	LFO Frequency	0.0Hz~39.70Hz	Speed	1	○
2	L/R Depth	0~127	L/RDpth	2	○
3	F/R Depth	0~127	F/RDpth	3	○
4	PAN Direction	L>R, L>R, L<R, L<R, Lum, Rtm, LR(0-5)	Directn	4	○
5	EQ Low Frequency	32Hz~2.0kHz	L.Freq	6	○
6	EQ Low Gain	-12dB~+12dB	L.Gain	7	○
7	EQ High Frequency	500Hz~16.0kHz	H.Freq	8	○
8	EQ High Gain	-12dB~+12dB	H.Gain	9	○
9	EQ Mid Frequency	100Hz~10.0kHz	M.Freq	11	○
10	EQ Mid Gain	-12dB~+12dB	M.Gain	12	○
11	EQ Mid Width	0.1~12.0	M.Width	13	○

[46] ROTARY SPEAKER1

No.	Parameter	Value	LCD	MIDI Parameter Number	Controller
1	LFO Frequency	0.0Hz~39.70Hz	Speed	1	○
2	LFO Depth	0~127	Depth	2	○
3	EQ Low Frequency	32Hz~2.0kHz	L.Freq	6	○
4	EQ Low Gain	-12dB~+12dB	L.Gain	7	○
5	EQ High Frequency	500Hz~16.0kHz	H.Freq	8	○
6	EQ High Gain	-12dB~+12dB	H.Gain	9	○
7	EQ Mid Frequency	100Hz~10.0kHz	M.Freq	11	○
8	EQ Mid Gain	-12dB~+12dB	M.Gain	12	○
9	EQ Mid Width	0.1~12.0	M.Width	13	○
10	Dry / Wet Balance	D63>W ~ D=W ~ D<W63	Dry/Wet	10	○

[47] DISTORTION+ROTARY SPEAKER1

[48] OVERDrive+ROTARY SPEAKER1

No.	Parameter	Value	LCD	MIDI Parameter Number	Controller
1	LFO Frequency	0.0Hz~39.70Hz	Speed	1	○
2	LFO Depth	0 ~ 127	Depth	2	○
3	Dist. Drive	0 ~ 127	Drive	14	○
4	Dist. LPF Cutoff Freq	1.0kHz~18.0kHz, thru	LPF	15	○
5	Dist. Output Level	0 ~ 127	DrivOut	16	○
6	EQ Low Frequency	32Hz~2.0kHz	L.Freq	6	○
7	EQ Low Gain	-12dB~+12dB	L.Gain	7	○
8	EQ High Frequency	500Hz~16.0kHz	H.Freq	8	○
9	EQ High Gain	-12dB~+12dB	H.Gain	9	○

[49] AMP SIMULATOR+ROTARY SPEAKER1

No.	Parameter	Value	LCD	MIDI Parameter Number	Controller
1	LFO Frequency	0.0Hz~39.70Hz	Speed	1	○
2	LFO Depth	0 ~ 127	Depth	2	○
3	AMP Type	off, stack, combo, tube	AmpType	3	○
4	AMP Drive	0 ~ 127	Drive	14	○
5	AMP LPF Cutoff Freq	1.0kHz~18.0kHz, thru	LPF	15	○
6	AMP Output Level	0 ~ 127	AmpOut	16	○
7	EQ Low Frequency	32Hz~2.0kHz	L.Freq	6	○
8	EQ Low Gain	-12dB~+12dB	L.Gain	7	○
9	EQ High Frequency	500Hz~16.0kHz	H.Freq	8	○
10	EQ High Gain	-12dB~+12dB	H.Gain	9	○

[50] ROTARY SPEAKER2

No.	Parameter	Value	LCD	MIDI Parameter Number	Controller
1	Rotor Speed	0.0Hz~39.70Hz	Speed	1	○
2	Drive Low	0~127	DriveLo	2	○
3	Drive High	0~127	DriveHi	3	○
4	Low / High Balance	L63>H ~ L=H ~ L<H63	Low/Hi	4	○
5	Mic L-R Angle	0deg~180deg	MicAngl	5	○
6	Divide Frequency	100Hz~10.0kHz	CrosOvr	11	○
7	EQ Low Frequency	32Hz~2.0kHz	L.Freq	6	○
8	EQ Low Gain	-12dB~+12dB	L.Gain	7	○
9	EQ High Frequency	500Hz~16.0kHz	H.Freq	8	○
10	EQ High Gain	-12dB~+12dB	H.Gain	9	○

[51] DISTORTION+ROTARY SPEAKER2

[52] OVERDrive+ROTARY SPEAKER2

No.	Parameter	Value	LCD	MIDI Parameter Number	Controller
1	Rotor Speed	0.0Hz~39.70Hz	Speed	1	○
2	Drive Low	0 ~ 127	DriveLo	2	○
3	Drive High	0 ~ 127	DriveHi	3	○
4	Low/High Balance	L63>H ~ L=H ~ L<H63	Low/Hi	4	○
5	Mic L-R Angle	0deg~180deg	MicAngl	12	○
6	Divide Frequency	100Hz~10.0kHz	CrosOvr	11	○
7	Dist.Drive	0 ~ 127	Drive	14	○
8	Dist. LPF Cutoff Freq	1.0kHz~18.0kHz, thru	LPF	15	○
9	Dist. Output Level	0 ~ 127	DrivOut	16	○
10	EQ Low Frequency	32Hz~2.0kHz	L.Freq	6	○
11	EQ Low Gain	-12dB~+12dB	L.Gain	7	○
12	EQ High Frequency	500Hz~16.0kHz	H.Freq	8	○
13	EQ High Gain	-12dB~+12dB	H.Gain	9	○

[53] AMP SIM.+ROTARY SPEAKER2

No.	Parameter	Value	LCD	MIDI Parameter Number	Controller
1	Rotor Speed	0.0Hz~39.70Hz	Speed	1	○
2	Drive Low	0 ~ 127	DriveLo	2	○
3	Drive High	0 ~ 127	DriveHi	3	○
4	Low/High Balance	L63>H ~ L=H ~ L<H63	Low/Hi	4	○
5	Mic L-R Angle	0deg~180deg	MicAngl	12	○
6	Divide Frequency	100Hz~10.0kHz	CrosOvr	11	○
7	AMP Type	off, stack, combo, tube	AmpType	13	○
8	AMP Drive	0 ~ 127	Drive	14	○
9	AMP LPF Cutoff Freq	1.0kHz~18.0kHz, thru	LPF	15	○
10	AMP Output Level	0 ~ 127	AmpOut	16	○
11	EQ Low Frequency	32Hz~2.0kHz	L.Freq	6	○
12	EQ Low Gain	-12dB~+12dB	L.Gain	7	○
13	EQ High Frequency	500Hz~16.0kHz	H.Freq	8	○
14	EQ High Gain	-12dB~+12dB	H.Gain	9	○

[54] ROTARY SPEAKER3

[55] ROTARY SPEAKER4

No.	Parameter	Value	LCD	MIDI Parameter Number	Controller
1	Speed Control	sLow, fast	Speed	16	○
2	SLOW-Fast Time of R	0-127	Trans:Rotor	5	○
3	SLOW-Fast Time of H	0-127	Trans:Horn	6	○
4	Rotor Speed SLOW	0.0Hz-2.65Hz	Rotor-Slw	1	○
5	Horn Speed SLOW	0.0Hz-2.65Hz	Horn-Slw	2	○
6	Rotor Speed Fast	2.69Hz-39.70Hz	Rotor-Fst	3	○
7	Horn Speed Fast	2.69Hz-39.70Hz	Horn-Fst	4	○
8	Mic L-R Angle	0deg-180deg	MicAngl	15	○
9	Drive Low	0-127	DriveLo	7	○
10	Drive High	0-127	DriveHi	8	○
11	Low/High Balance	L63>H - L=H - L<H63	Low/Hi	9	○
12	EQ Low Frequency	32Hz-2.0kHz	L.Freq	11	○
13	EQ Low Gain	-12dB-+12dB	L.Gain	12	○
14	EQ High Frequency	500Hz-16.0kHz	H.Freq	13	○
15	EQ High Gain	-12dB-+12dB	H.Gain	14	○

[56] DISTORTION

No.	Parameter	Value	LCD	MIDI Parameter Number	Controller
1	Drive	0-127	Drive	1	○
2	Edge	0-127	Edge	11	○
3	Output Level	0-127	OutLvl	5	○
4	EQ Low Frequency	32Hz-2.0kHz	L.Freq	2	○
5	EQ Low Gain	-12dB-+12dB	L.Gain	3	○
6	LPF Cutoff Frequency	1.0kHz-20.0kHz	LPF	4	○
7	EQ Mid Frequency	100Hz-10.0kHz	M.Freq	7	○
8	EQ Mid Gain	-12dB-+12dB	M.Gain	8	○
9	EQ Mid Width	0.1-12.0	M.Width	9	○
10	Dry / Wet Balance	D63>W - D=W - D<W63	Dry/Wet	10	○

[57] COMP DISTORTION

No.	Parameter	Value	LCD	MIDI Parameter Number	Controller
1	Attack	1ms-40ms	Attack	12	○
2	Release	10ms-680ms	Release	13	○
3	Threshold	-48dB--6dB	Thrsld	14	○
4	Ratio	1-20.0	Ratio	15	○
5	EQ Low Frequency	32Hz-2.0kHz	L.Freq	2	○
6	EQ Low Gain	-12dB-+12dB	L.Gain	3	○
7	Drive	0-127	Drive	1	○
8	Output Level	0-127	OutLvl	5	○
9	EQ Mid Frequency	100Hz-10.0kHz	M.Freq	7	○
10	EQ Mid Gain	-12dB-+12dB	M.Gain	8	○
11	EQ Mid Width	0.1-12.0	M.Width	9	○
12	Edge	0-127	Edge	11	○
13	LPF Cutoff Frequency	1.0kHz-20.0kHz	LPF	4	○
14	Dry / Wet Balance	D63>W - D=W - D<W63	Dry/Wet	10	○

[58] V-DISTORTION

No.	Parameter	Value	LCD	MIDI Parameter Number	Controller
1	Over Drive	0 ~ 100%	OverDr	1	○
2	Device	Transistor, Vintage Tube, Distorion1, Distorion2, Fuzz	Device	2	○
3	Speaker Type	Flat, Stack, Combo, Twin, Radio, Megaphone	Speaker	3	○
4	Presence	-10 ~ 10	Presenc	4	○
5	Delay Time L	0.1ms-1486.0ms	DelayL	6	○
6	Delay Time R	0.1ms-1486.0ms	DelayR	7	○
7	Feedback Time	0.1ms-1486.0ms	FBTime	8	○
8	Feedback Level	-63-+63	FBLevel	9	○
9	Feedback High Damp	0.1-1.0	FBHiDmp	12	○
10	Output Level	0 ~ 100%	DistLvl	5	○
11	Delay Mix	0 ~ 127	DlyMix	11	○
12	Dry/Wet Balance	D63>W - D=W - D<W63	Dry/Wet	10	○

[59] OVERDRIVE

No.	Parameter	Value	LCD	MIDI Parameter Number	Controller
1	Drive	0-127	Drive	1	○
2	Edge	0-127	Edge	11	○
3	Output Level	0-127	OutLvl	5	○
4	EQ Low Frequency	32Hz-2.0kHz	L.Freq	2	○
5	EQ Low Gain	-12dB-+12dB	L.Gain	3	○
6	LPF Cutoff Frequency	1.0kHz-20.0kHz	LPF	4	○
7	EQ Mid Frequency	100Hz-10.0kHz	M.Freq	7	○
8	EQ Mid Gain	-12dB-+12dB	M.Gain	8	○
9	EQ Mid Width	0.1-12.0	M.Width	9	○
10	Dry / Wet Balance	D63>W - D=W - D<W63	Dry/Wet	10	○

[60] AMP SIMULATOR

No.	Parameter	Value	LCD	MIDI Parameter Number	Controller
1	AMP Type	off, stack, combo, tube	AmpType	2	○
2	Drive	0-127	Drive	1	○
3	Edge	0-127	Edge	11	○
4	Output Level	0-127	OutLvl	4	○
5	LPF Cutoff Frequency	1.0kHz-20.0kHz	LPF	3	○
6	Dry / Wet Balance	D63>W - D=W - D<W63	Dry/Wet	10	○

[61] DIST+DELAY

[62] OVERDRIVE+DELAY

No.	Parameter	Value	LCD	MIDI Parameter Number	Controller
1	Dist. Drive	0-127	Drive	6	○
2	Dist. EQ Low Gain	-12dB-+12dB	EQ-Low	8	○
3	Dist. EQ Mid Gain	-12dB-+2dB	EQ-Mid	9	○
4	Dist Output Level	0-127	DrivOut	7	○
5	Delay Time L	0.1ms-1486.0ms	DelayL	1	○
6	Delay Time R	0.1ms-1486.0ms	DelayR	2	○
7	Delay Feedback Time	0.1ms-1486.0ms	FBTime	3	○
8	Delay Feedback Level	-63-+63	FBLevel	4	○
9	Delay mix	0-127	DlyMix	5	○
10	Dry / Wet Balance	D63>W - D=W - D<W63	Dry/Wet	10	○

[63] COMPRESSOR1

No.	Parameter	Value	LCD	MIDI Parameter Number	Controller
1	Attack	1ms-40ms	Attack	1	○
2	Release	10ms-680ms	Release	2	○
3	Threshold	-48dB--6dB	Thrsld	3	○
4	Ratio	1-20.0	Ratio	4	○
5	Output Level	0-127	OutLvl	5	○

[64] NOISE GATE

No.	Parameter	Value	LCD	MIDI Parameter Number	Controller
1	Attack	1ms-40ms	Attack	1	○
2	Release	10ms-680ms	Release	2	○
3	Threshold	-72dB--30dB	Thrsld	3	○
4	Output Level	0-127	OutLvl	4	○

[65] COMP+DIST+DELAY

[66] COMP+ODRV+DELAY

No.	Parameter	Value	LCD	MIDI Parameter Number	Controller
1	Comp. Attack	1ms-40ms	Attack	11	○
2	Comp. Release	10ms-680ms	Release	12	○
3	Comp. Threshold	-48dB--6dB	Thrsld	13	○
4	Comp. Ratio	1-20.0	Ratio	14	○
5	Dist. Drive	0-127	Drive	4	○
6	Dist. EQ Low Gain	-12dB-+12dB	EQ-Low	6	○
7	Dist. EQ Mid Gain	-12dB-+12dB	EQ-Mid	7	○
8	Dist Output Level	0-127	DrivOut	5	○
9	Delay Time	0.1ms-1486.0ms	DlyTime	1	○
10	Delay Feedback Level	-63-+63	FBLevel	2	○
11	Delay Mix	0-127	DlyMix	3	○
12	Dry / Wet Balance	D63>W - D=W - D<W63	Dry/Wet	10	○

[67] PITCH CHANGE1

[68] PITCH CHANGE2

No.	Parameter	Value	LCD	MIDI Parameter Number	Controller
1	Pitch	-24-+24	Pitch	1	○
2	Initial Delay	0.1ms-248.9ms	InitDly	2	○
3	Feedback Level	-63-+63	FBLevel	5	○
4	Dry / Wet Balance	D63>W - D=W - D<W63	Dry/Wet	10	○
5	Fine1	-50-+50	Fine1	3	○
6	Fine2	-50-+50	Fine2	4	○
7	Pan1	L63-C-R63	Pan1	11	○
8	Output Level1	0-127	OutLvl1	12	○
9	Pan2	L63-C-R63	Pan2	13	○
10	Output Level2	0-127	OutLvl2	14	○

In [68] PITCH CHANGE 2, the unit of Fine 1 and Fine 2 (numbers 5 and 6) is cent.

[69] AUTO WAH

No.	Parameter	Value	LCD	MIDI Parameter Number	Controller
1	LFO Frequency	0.0Hz-39.70Hz	Speed	1	○
2	LFO Depth	0-127	Depth	2	○
3	Cutoff Frequency Offset	0-127	Cutoff	3	○
4	Resonance	1-12.0	Reso	4	○
5	EQ Low Frequency	32Hz-2.0kHz	L.Freq	6	○
6	EQ Low Gain	-12dB-+12dB	L.Gain	7	○
7	EQ High Frequency	500Hz-16.0kHz	H.Freq	8	○
8	EQ High Gain	-12dB-+12dB	H.Gain	9	○
9	Dry / Wet Balance	D63>W - D=W - D<W63	Dry/Wet	10	○

[70] AUTO WAH + DIST**[71] AUTO WAH + OVERDRIVE**

No.	Parameter	Value	LCD	MIDI Parameter Number	Controller
1	LFO Frequency	0.0Hz~39.70Hz	Speed	1	○
2	LFO Depth	0~127	Depth	2	○
3	Cutoff Frequency Offset	0~127	Cutoff	3	○
4	Resonance	1~12.0	Reso	4	○
5	EQ Low Frequency	32Hz~2.0kHz	L.Freq	6	○
6	EQ Low Gain	-12dB~+12dB	L.Gain	7	○
7	EQ High Frequency	500Hz~16.0kHz	H.Freq	8	○
8	EQ High Gain	-12dB~+12dB	H.Gain	9	○
9	Dist Low Gain	-12dB~+12dB	Drive:EQ-Low	12	○
10	Dist Mid Gain	-12dB~+12dB	Drive:EQ-Mid	13	○
11	LPF Cutoff Frequency	1.0kHz~20.0kHz	LPF	14	○
12	Drive	0~127	Drive	11	○
13	Output Level	0~127	DrivOut	15	○
14	Dry / Wet Balance	D63>W ~ D=W ~ D<W63	Dry/Wet	10	○

[72] TOUCH WAH

No.	Parameter	Value	LCD	MIDI Parameter Number	Controller
1	Sensitive	0~127	Sens	1	○
2	Cutoff Frequency Offset	0~127	Cutoff	2	○
3	Resonance	1~12.0	Reso	3	○
4	EQ Low Frequency	32Hz~12.0kHz	L.Freq	6	○
5	EQ Low Gain	-12dB~+12dB	L.Gain	7	○
6	EQ High Frequency	500Hz~16.0kHz	H.Freq	8	○
7	EQ High Gain	-12dB~+12dB	H.Gain	9	○
8	Dry / Wet Balance	D63>W ~ D=W ~ D<W63	Dry/Wet	10	○

[73] TOUCH WAH + DIST**[74] TOUCH WAH + OVERDRIVE**

No.	Parameter	Value	LCD	MIDI Parameter Number	Controller
1	Sensitive	0~127	Sens	1	○
2	Cutoff Frequency Offset	0~127	Cutoff	2	○
3	Resonance	1~12.0	Reso	3	○
4	EQ Low Frequency	32Hz~2.0kHz	L.Freq	6	○
5	EQ Low Gain	-12dB~+12dB	L.Gain	7	○
6	EQ High Frequency	500Hz~16.0kHz	H.Freq	8	○
7	EQ High Gain	-12dB~+12dB	H.Gain	9	○
8	Dist Low Gain	-12dB~+12dB	Drive:EQ-Low	12	○
9	Dist Mid Gain	-12dB~+12dB	Drive:EQ-Mid	13	○
10	LPF Cutoff Frequency	1.0kHz~20.0kHz	LPF	14	○
11	Drive	0~127	Drive	11	○
12	Output Level	0~127	DrivOut	15	○
13	Dry / Wet Balance	D63>W ~ D=W ~ D<W63	Dry/Wet	10	○

[75] WAH + DIST + DELAY**[76] WAH + OVERDRIVE + DELAY**

No.	Parameter	Value	LCD	MIDI Parameter Number	Controller
1	Wah sensitive	0~127	WahSens	11	○
2	Wah Cutoff Frequency	0~127	Cutoff	12	○
3	Wah Resonance	1~12.0	Reso	13	○
4	Wah release	10ms~680ms	Release	14	○
5	Dist. Drive	0~127	Drive	4	○
6	Dist. EQ Low Gain	-12dB~+12dB	EQ-Low	6	○
7	Dist. EQ Mid Gain	-12dB~+12dB	EQ-Mid	7	○
8	Dist Output Level	0~127	DrivOut	5	○
9	Delay Time	0.1ms~1486.0ms	Delay	1	○
10	Delay Feedback Level	-63~+63	FBLevel	2	○
11	Delay mix	0~127	DlyMix	3	○
12	Dry / Wet Balance	D63>W ~ D=W ~ D<W63	Dry/Wet	10	○

[77] LO-FI

No.	Parameter	Value	LCD	MIDI Parameter Number	Controller
1	Sampling Freq. Control	44.1kHz~344Hz	SmplFrq	1	○
2	Word Length	1~127	WordLen	2	○
3	Output Gain	-6dB~+36dB	OutGain	3	○
4	Filter Type	thru, PowerBass, Radio, Telephone, Clean, Low	FltType	5	○
5	Pre-LPF Cutoff Frequency	63Hz~20.0kHz	Cutoff	4	○
6	Pre-LPF Resonance	1~12.0	Reso	6	○
7	Bit Assign	0~6	BitAsgn	7	○
8	Emphasis	off/on	Emphasi	8	○
9	Input Mode	mono/stereo	Input	15	○
10	Dry / Wet Balance	D63>W ~ D=W ~ D<W63	Dry/Wet	10	○

[78] LOW RESOLUTION

No.	Parameter	Value	LCD	MIDI Parameter Number	Controller
1	Mod Depth	0~127	ModDpth	1	○
2	Mod Delay Offset	1~127	ModDly	2	○
3	Mod Mix Balance	0~127	ModMix	5	○
4	Resolution	1,1/2~1/128	Resoltn	4	○
5	Mod Feedback	-63~+63	ModFB	3	○
6	Phase Inverse R	off, wet, wet+dry	PhasInlv	6	○
7	Dry/Wet Balance	D63>W ~ D=W ~ D<W63	Dry/Wet	7	○

[79] NOISY

No.	Parameter	Value	LCD	MIDI Parameter Number	Controller
1	Mod Depth	0~10	ModDpth	2	○
2	Mod Speed	0~127	ModSpd	3	○
3	Mod Feedback	-63~+63	ModFB	4	○
4	Mod Mix Balance	1~127	ModMix	7	○
5	Drive	0~127	Drive	1	○
6	AM Speed	0.00Hz~39.7Hz	AMSpeed	5	○
7	AM Depth	0~127	AMDepth	6	○
8	LPF Frequency	1.0kHz~20.0kHz	Cutoff	8	○
9	LPF Resonance	1.0~12.0	Reso	9	○
10	EQ Frequency	100Hz~10.0kHz	EQFreq	10	○
11	EQ Gain	-12~+12dB	EQGain	11	○
12	EQ Width	1.0~12.0	EQWidth	12	○
13	Dry/Wet Balance	D63>W ~ D=W ~ D<W63	Dry/Wet	13	○

[80] ATTACK LOFI

No.	Parameter	Value	LCD	MIDI Parameter Number	Controller
1	Sensitive	0~127	Sens	1	○
2	Resolution	1,1/2~1/32	Resoltn	2	○
3	Peak Frequency	100Hz~10.0kHz	PeakFrq	3	○
4	LPF Frequency	1.0kHz~20.0kHz	LPF	4	○
5	Flanger Speed	0.00Hz~39.7Hz	FlgSpd	5	○
6	Flanger LFO Wave	tri, sine, saw up, saw down	FlgWave	6	○
7	Flanger Depth	0~127	FlgDpt	7	○
8	Fln Depth Ofst R	-63~+63	FlgDptR	8	○
9	Flanger Delay	0.1~650.0ms	FlgDly	9	○
10	Fln Delay Ofst R	0~884	FlgDlyR	10	○
11	Flanger Feedback	-63~+63	FlgFB	11	○
12	Flanger FB Ofst R	-63~+63	FlgFB R	12	○
13	Flanger FB HiDamp	0.1~1.0	FBHiDmp	13	○
14	FB HiDamp Ofst R	-0.9~+0.9	FBHiDmR	14	○
15	Fln Mix Balance	1~127	FlgMix	15	○
16	Dry/Wet Balance	D63>W ~ D=W ~ D<W63	Dry/Wet	16	○

[81] DIGITAL TURNTABLE

No.	Parameter	Value	LCD	MIDI Parameter Number	Controller
1	Click Density	0~5	Density	1	○
2	Click Level	0~127	Click	2	○
3	Noise Tone	0~6	NoisTon	3	○
4	Dry Send to Noise	0~127	DryNois	6	○
5	Noise Mod Speed	0.00Hz~39.7Hz	ModSpd	4	○
6	Noise Mod Depth	0~127	ModDpth	5	○
7	Noise LPF Freq	1.0kHz~20.0kHz	NoisLPF	7	○
8	Noise LPF Q	1.0~12.0	NoiseQ	8	○
9	Noise Level	0~127	NoisLvl	9	○
10	Dry LPF Frequency	1.0kHz~20.0kHz	DryLPF	10	○
11	Dry Level	0~127	DryLvl	11	○

[82] DIGITAL SCRATCH

No.	Parameter	Value	LCD	MIDI Parameter Number	Controller
1	Input Level	0~127	Input	1	○
2	Initial Delay	0.1~460.0ms	Delay	2	○
3	Scratch Speed	1~127	ScrSpd	3	○
4	Scratch Depth	0~127	ScrDpth	4	○
5	HPF Frequency	20Hz~8.0kHz	HPF	10	○
6	Auto Pan Speed	0.00Hz~39.7Hz	PanSpd	5	○
7	Auto Pan Depth	0~127	PanDpth	6	○
8	EQ Frequency	100Hz~10.0kHz	EQFreq	7	○
9	EQ Gain	-12~+12dB	EQGain	8	○
10	EQ Width	1.0~12.0	EQWidth	9	○
11	Dry/Wet Balance	D63>W ~ D=W ~ D<W63	Dry/Wet	11	○

[83] AUTO SYNTH

No.	Parameter	Value	LCD	MIDI Parameter Number	Controller
1	Mod Speed	0-127	ModSpd	1	○
2	Mod Wave Type	TypeA, TypeB, TypeC, TypeD	ModWave	2	
3	Mod Depth	0-127	ModDpth	3	○
4	Mod Depth Ofst R	-63-+63	ModDpth-R Ofst	4	○
5	HPF Frequency	20Hz-8.0kHz	HPF	6	○
6	LPF Frequency	1.0kHz-20.0kHz	LPF	5	○
7	Dry Mix Level	0-127	DryMix	7	○
8	Delay Level	0-127	DlyLvl	12	○
9	Delay Time	0.1-370.0ms	Delay	8	
10	Delay Time Ofst R	0-884	Delay-R Ofst	9	
11	Feedback Level	-63-+63	FBLevel	10	○
12	FB Level Ofst R	-63-+63	FBLevel-R Ofst	11	○
13	AM Speed	0.00Hz-39.7Hz	AMSpeed	13	○
14	AM Wave	tri, sine, saw up, saw down	AM Wave	14	
15	AM Depth	0-127	AMDepth	15	○
16	AM Inverse R	normal, inverse	AM InvR	16	

[84] TECH MODULATION

No.	Parameter	Value	LCD	MIDI Parameter Number	Controller
1	Mod Speed	0-127	Speed	1	○
2	Mod Depth	0-127	Depth	2	○
3	Mod Gain	-12-+12dB	Gain	4	○
4	Mod Mix Balance	D63>W ~ D=W ~ D<W63	ModMix	7	○
5	Pre Mod HPF Freq	20Hz-8.0kHz	HPF	3	○
6	Mod LPF Frequency	1.0kHz-20.0kHz	LPF:Cutoff	5	○
7	Mod LPF Resonance	1.0-12.0	LPF:Reso	6	○
8	Delay Time	0.1-740.0ms	Delay	8	
9	Delay Time Ofst R	0-884	Delay-R Ofst	9	
10	Feedback Level	-63-+63	FBLevel	10	○
11	FB Level Ofst R	-63-+63	FBLevel-R Ofst	11	○
12	Feedback Hi Damp	0.1-1.0	FBHiDmp	12	○
13	FB Hi Damp Ofst R	-0.9-+0.9	FBHiDmp-R Ofst	13	○
14	Dry/Wet Balance	D63>W ~ D=W ~ D<W63	Dry/Wet	14	○

[85] JUMP

No.	Parameter	Value	LCD	MIDI Parameter Number	Controller
1	Depth	0-127	Depth	1	○
2	Speed	0-127	Speed	2	○
3	Direction	L<>R,L>>R	Directn	3	
4	Type	TypeA, TypeB, TypeC	Type	4	
5	Jump Wave Type	TypeA, TypeB, TypeC, TypeD	JumpWave	5	
6	Resolution	1,1/2-1/256	Resolution	6	
7	HPF Frequency	20Hz-8.0kHz	HPF	8	○
8	LPF Frequency	1.0kHz-20.0kHz	LPF	7	○
9	Dry/Wet Balance	D63>W ~ D=W ~ D<W63	Dry/Wet	9	○

[86] 2BAND EQ

No.	Parameter	Value	LCD	MIDI Parameter Number	Controller
1	EQ Low Frequency	32Hz-2.0kHz	L.Freq	1	○
2	EQ Low Gain	-12dB-+12dB	L.Gain	2	○
3	EQ High Frequency	500Hz-16.0kHz	H.Freq	3	○
4	EQ High Gain	-12dB-+12dB	H.Gain	4	○

[87] 3BAND EQ

No.	Parameter	Value	LCD	MIDI Parameter Number	Controller
1	EQ Low Frequency	50Hz-2.0kHz	L.Freq	6	○
2	EQ Low Gain	-12dB-+12dB	L.Gain	1	○
3	EQ High Frequency	500Hz-16.0kHz	H.Freq	7	○
4	EQ High Gain	-12dB-+12dB	H.Gain	5	○
5	EQ Mid Frequency	100Hz-10.0kHz	M.Freq	2	○
6	EQ Mid Gain	-12dB-+12dB	M.Gain	3	○
7	EQ Mid Width	0.1-12.0	M.Width	4	○
8	Input Mode	mono/stereo	Input	15	

[88] HARMONIC ENHANCER

No.	Parameter	Value	LCD	MIDI Parameter Number	Controller
1	HPF Cutoff Frequency	500Hz-16.0kHz	HPF	1	○
2	Drive	0-127	Drive	2	○
3	Mix Level	0-127	MixLvl	3	○

[89] VOICE CANCELAR

No.	Parameter	Value	LCD	MIDI Parameter Number	Controller
1	Low Adjust	0-26	LowAdj	11	○
2	High Adjust	0-26	HighAdj	12	○

[90] AMBIENCE

No.	Parameter	Value	LCD	MIDI Parameter Number	Controller
1	Delay Time	0.0ms-50.0ms	DlyTime	1	
2	Wet Output Phase	normal/inverse	WetPhase	2	○
3	Dry / Wet Balance	D63>W - D=W - D<W63	Dry/Wet	10	○
4	EQ Low Frequency	32Hz-2.0kHz	L.Freq	6	○
5	EQ Low Gain	-12dB-+12dB	L.Gain	7	○
6	EQ High Frequency	500Hz-16.0kHz	H.Freq	8	○
7	EQ High Gain	-12dB-+12dB	H.Gain	9	○

[91] TALKING MODULATOR

No.	Parameter	Value	LCD	MIDI Parameter Number	Controller
1	Vowel	a/i/u/e/o	Vowel	1	○
2	Move Speed	1- 62	Speed	2	○
3	Drive	0-127	Drive	3	○
4	Output Level	0-127	OutLvl	4	○

[92] BEAT CHANGE

No.	Parameter	Value	LCD	MIDI Parameter Number	Controller
1	Beat Change	-63-+63	BeatChg	1	○
2	Beat Range	0-12	BeatRng	2	○
3	Pitch Change	-63-+63	PchChg	3	○
4	Pitch Range	0-12	PchRng	4	○
5	EQ Frequency	32Hz-2.0kHz	EQFreq	6	○
6	EQ Gain	-12dB-+12dB	EQGain	7	○
7	EQ Width	1.0-12.0	EQWidth	8	○
8	Accuracy Type	sound4-normal-rythm4	AccType	5	
9	Dry/Wet Balance	D63>W ~ D=W ~ D<W63	Dry/Wet	10	○

About MIDI

MIDI is an acronym that stands for Musical Instrument Digital Interface, which allows electronic musical instruments to “communicate” with each other, by sending and receiving compatible Note, Control Change, Program Change and various other types of MIDI data, or messages.

The S30 can control a MIDI device by transmitting note related data and various types of controller data. The S30 can be controlled by the incoming MIDI messages which automatically select MIDI channels, voices and effects, change parameter values, and of course play the voices specified for the various Parts in a Performance.

MIDI Messages Transmitted/Received by the S30

The MIDI messages can be divided into two groups: the Channel Messages and System Messages. Below is a brief explanation of the various types of MIDI messages which the S30 can receive/transmit.

CHANNEL MESSAGES

The Channel Messages are the data related to the performance on the keyboard for the specific channel.

•Note On/Note Off (Key On/Key Off)

Messages which are generated when the keyboard is played. Each message includes a specific note number which corresponds to the key which is pressed, plus a velocity value based on how hard the key is struck.

•Control Change

Control Change messages let you select a voice bank (Bank Select), control volume, panning, modulation, portamento time, brightness and various other controller parameters, through specific Control Change numbers which correspond to each of the various parameters.

•Program Change

Messages which voice to select for each Part.

With a combination of Bank Select, you can select not only basic voice numbers, but also variation voice bank numbers.

•Channel Aftertouch

Messages which let you control the sounds by the pressure you apply to the keys after the initial striking of the keys, over the entire channel.

•Polyphonic Key Pressure

Messages which let you control the sounds by the pressure you apply to the keys after the initial striking of the keys, for each individual key. The internal sequencer (S30) can send this message.

•Pitch Bend

Pitch Bend messages are continuous controller messages that allow the pitch of designated notes to be raised or lowered by a specified amount over a specified duration.

SYSTEM MESSAGES

The System Messages are the data related to the overall system of the device.

•Exclusive Messages

Exclusive messages control various functions of the S30, including bulk dump, master volume and master tuning, effect type and various other parameters.

•Realtime Messages

Messages which control the sequencer including Start, Stop, Continue, MIDI clock and Active Sensing messages.

•Common Messages

Messages which also control the sequencer including Song Select and Song Position Pointer messages.

MIDI Data Format

Many MIDI messages listed in the MIDI Data Format section are expressed in hexadecimal or binary numbers. Hexadecimal numbers may include the letter “H” as a suffix. The letter “n” indicates a certain whole number.

The chart below lists the corresponding decimal number for each hexadecimal/binary number.

Decimal	Hexadecimal	Binary
0	00	0000 0000
1	01	0000 0001
2	02	0000 0010
3	03	0000 0011
4	04	0000 0100
5	05	0000 0101
6	06	0000 0110
7	07	0000 0111
8	08	0000 1000
9	09	0000 1001
10	0A	0000 1010
11	0B	0000 1011
12	0C	0000 1100
13	0D	0000 1101
14	0E	0000 1110
15	0F	0000 1111
16	10	0001 0000
17	11	0001 0001
18	12	0001 0010
19	13	0001 0011
20	14	0001 0100
21	15	0001 0101
22	16	0001 0110
23	17	0001 0111
24	18	0001 1000
25	19	0001 1001
26	1A	0001 1010
27	1B	0001 1011
28	1C	0001 1100
29	1D	0001 1101
30	1E	0001 1110
31	1F	0001 1111
32	20	0010 0000
33	21	0010 0001
34	22	0010 0010
35	23	0010 0011
36	24	0010 0100
37	25	0010 0101
38	26	0010 0110
39	27	0010 0111
40	28	0010 1000
41	29	0010 1001
42	2A	0010 1010
43	2B	0010 1011
44	2C	0010 1100
45	2D	0010 1101
46	2E	0010 1110
47	2F	0010 1111
48	30	0011 0000
49	31	0011 0001
50	32	0011 0010
51	33	0011 0011
52	34	0011 0100
53	35	0011 0101
54	36	0011 0110
55	37	0011 0111
56	38	0011 1000
57	39	0011 1001
58	3A	0011 1010
59	3B	0011 1011
60	3C	0011 1100
61	3D	0011 1101
62	3E	0011 1110
63	3F	0011 1111

Decimal	Hexadecimal	Binary
64	40	0100 0000
65	41	0100 0001
66	42	0100 0010
67	43	0100 0011
68	44	0100 0100
69	45	0100 0101
70	46	0100 0110
71	47	0100 0111
72	48	0100 1000
73	49	0100 1001
74	4A	0100 1010
75	4B	0100 1011
76	4C	0100 1100
77	4D	0100 1101
78	4E	0100 1110
79	4F	0100 1111
80	50	0101 0000
81	51	0101 0001
82	52	0101 0010
83	53	0101 0011
84	54	0101 0100
85	55	0101 0101
86	56	0101 0110
87	57	0101 0111
88	58	0101 1000
89	59	0101 1001
90	5A	0101 1010
91	5B	0101 1011
92	5C	0101 1100
93	5D	0101 1101
94	5E	0101 1110
95	5F	0101 1111
96	60	0110 0000
97	61	0110 0001
98	62	0110 0010
99	63	0110 0011
100	64	0110 0100
101	65	0110 0101
102	66	0110 0110
103	67	0110 0111
104	68	0110 1000
105	69	0110 1001
106	6A	0110 1010
107	6B	0110 1011
108	6C	0110 1100
109	6D	0110 1101
110	6E	0110 1110
111	6F	0110 1111
112	70	0111 0000
113	71	0111 0001
114	72	0111 0010
115	73	0111 0011
116	74	0111 0100
117	75	0111 0101
118	76	0111 0110
119	77	0111 0111
120	78	0111 1000
121	79	0111 1001
122	7A	0111 1010
123	7B	0111 1011
124	7C	0111 1100
125	7D	0111 1101
126	7E	0111 1110
127	7F	0111 1111

Additional Notes

- For example, 144 - 159(Decimal)/9nH/1001 0000 - 1001 1111(Binary) indicate the note-on messages for the channels 1 through 16 respectively. 176 - 191/BnH/1011 0000 - 1011 1111 indicate the control change messages for the channels 1 through 16 respectively. 192 - 207/CnH/1100 0000 - 1100 1111 indicate the program change messages for the channels 1 through 16 respectively. 240/F0H/1111 0000 is positioned at the beginning of data to indicate a system exclusive message. 247/F7H/1111 0111 is positioned at the end of the system exclusive message.
- aaH(Hexadecimal)/0aaaaaaaa(Binary) indicates the data addresses. The data address consists of High, Mid and Low.
- bbH/0bbbbbbb indicates byte counts.
- ccH/0ccccccc indicates tcheck sums.
- ddH/0ddddddd indicates data/value.

SYNTHESIZER/SEQUENCER PART

1) TRANSMIT FLOW

```

MIDI <-[SW1]++++ NOTE ON/OFF          9nH
OUT |
    | +--- CONTROL CHANGE
    | +{SW8}--BANK SEL MSB      BnH,00H
    |   BANK SEL LSB          BnH,20H
    |   MODULATION             BnH,01H
    |   ASSIGNABLE CONTROLLER BnH,(00H .. 5FH)
    |
    | +--- PROGRAM CHANGE        CnH
    | +--- CHANNEL AFTER TOUCH  DnH
    | +--- PITCH BEND CHANGE     EnH
    |
    | -[SW3,4]--SYSTEM REALTIME MESSAGE
    |   TIMING CLOCK            F8H
    |
    | -[SW4]----SYSTEM REALTIME MESSAGE
    |   START                   FAH
    |   CONTINUE                FBH
    |   STOP                    FCH
    |
    | +{SW5}++++ SYSTEM EXCLUSIVE MESSAGE
    | |
    | | -[SW7]-<BULK DUMP>       FOH 43H 0nH 64H bhH b1H ahH amH alH ddH....ddH ccH F7H
    | |
    | | -[SW7]-<PARAMETER CHANGE> FOH 43H 1nH 64H ahH amH alH ddH....ddH F7H
    | |
    | | ----- SYSTEM EXCLUSIVE MESSAGE
    | |   IDENTITY REPLY        FOH 7EH 7FH 06H 02H 43H 00H 41H ddH ddH 00H 00H 00H 7FH F7H
    | |
    | | ----- ACTIVE SENSING   FEH
  
```

[SW1] MIDI Transmit Channel
 Master Keyboard Mode = on: complies with Zone Transmit Channel.
 Master Keyboard Mode = off: complies with Keyboard Transmit Channel.
 The data played back using Sequencer Part will be output through the channels set for the sequence data, ignoring [SW1] settings.

[SW3] MIDI Sync

[SW4] MIDI Control

[SW5] MIDI Device Number
 When set to all, data will be output through the channel 1.

[SW7] In the VOICE MODE, VOICE related data only. In the PERFORMANCE MODE, PERFORMANCE related data only.
 SYSTEM data will be transmitted/received in all modes.

[SW8] SYSTEM Bank Select Switch

2) RECEIVE FLOW

```

MIDI >-[SW11]++++ NOTE OFF          8nH
    |
    | +--- NOTE ON/OFF          9nH
    |
    | +--- CONTROL CHANGE
    |   MODULATION              BnH,01H
    |   PORTAMENTO TIME         BnH,05H
    |   DATA ENTRY MSB        BnH,06
    |   DATA ENTRY LSB        BnH,26H
    |   MAIN VOLUME             BnH,07H
    |   PAN                     BnH,0AH
    |   EXPRESSION              BnH,0BH
    |   SUSTAIN SWITCH         BnH,40H
    |   PORTAMENTO SWITCH      BnH,41H
    |   SOSTENUTO              BnH,42H
    |   HARMONIC CONTENT       BnH,47H
    |   EG RELEASE TIME        BnH,48H
    |   EG ATTACK TIME         BnH,49H
    |   BRIGHTNESS             BnH,4AH
    |   EG DECAY TIME          BnH,4BH
    |   EFFECT1 DEPTH          BnH,5BH
    |   EFFECT3 DEPTH          BnH,5DH
    |   DATA ENTRY INC        BnH,60H
    |   DATA ENTRY DEC        BnH,61H
    |   ASSIGNABLE CONTROLLER BnH,(00H .. 5FH)
    |   RPN
    |     PITCH BEND SENS      BnH,64H,00H,65H,00H,06H,mmH
    |     FINE TUNING          BnH,64H,01H,65H,00H,06H,mmH,26H,11H *1
    |     COARSE TUNING       BnH,64H,02H,65H,00H,06H,mmH *1
    |     RPN RESET           BnH,64H,7FH,65H,7FH
    |     ALL SOUND OFF       BnH,78H
    |     RESET ALL CONTROLLERS BnH,79H
    |     ALL NOTE OFF        BnH,7BH
    |     OMNI MODE OFF       BnH,7CH
    |     OMNI MODE ON        BnH,7DH
    |     MONO MODE           BnH,7EH
    |     POLY MODE           BnH,7FH
    |
    | +{SW8}--BANK SEL MSB      BnH,00H
    |   BANK SEL LSB          BnH,20H
    |
    | +{SW9}--PROGRAM CHANGE    CnH
    |
    | +-----CHANNEL AFTER TOUCH DnH
    |
    | +-----PITCH BEND CHANGE  EnH
    |
    | +-----+ SYSTEM EXCLUSIVE MESSAGE
    | |
    | |   IDENTITY REQUEST      FOH 7EH 0nH 06H 01H F7H
    | |   REMOTE SWITCH         FOH 43H 10H 64H 0AH 00H alH ddH F7H
    | |
    | | +[SW12]- GM MODE ON      FOH 7EH 7FH 09H 01H F7H
    | |
    | | +{SW5}+ SYSTEM EXCLUSIVE MESSAGE
    | |   MIDI MASTER VOLUME    FOH 7FH 7FH 04H 01H 11H mmH F7H
    | |
    | | +[SW10]-<BULK DUMP>      FOH 43H 0nH 64H bhH b1H ahH amH alH ddH....ddH ccH F7H
    | |
    | | +[SW7]-<PARAMETER CHANGE> FOH 43H 1nH 64H ahH amH alH ddH....ddH F7H
    | |
    | | +[SW7]-<BULK DUMP REQUEST> FOH 43H 2nH 64H ahH amH alH ddH....ddH F7H
    | |
    | | +[SW7]-<PARAMETER REQUEST> FOH 43H 3nH 64H ahH amH alH F7H
    | |
    | | +[SW12]-XG SYSTEM ON     FOH 43H 1nH 4CH 00H 00H 7EH 00H F7H
    | |
    | | +[SW3]----- SYSTEM REALTIME MESSAGE
    | |   TIMING CLOCK          F8H
    | |
    | | +[SW4]----- SYSTEM REALTIME MESSAGE
    | |   START                 FAH
    | |   CONTINUE              FBH
    | |   STOP                  FCH
    | |
    | | +----- ACTIVE SENSING   FEH
  
```

[SW3] MIDI Sync

[SW4] MIDI Control

[SW5] MIDI Device Number
 When set to the number other than off, MIDI MASTER VOLUME will be received.

[SW7] In the VOICE MODE, VOICE related data only. In the PERFORMANCE MODE, PERFORMANCE related data only.
 SYSTEM data will be transmitted/received in all modes.

[SW8] SYSTEM Bank Select Switch

[SW9] SYSTEM Program Change Switch (Received only in the Play Mode when Voice Mode is selected.)

[SW10] SYSTEM Bulk Protect and the conditions mentioned in SW7 above.

[SW11] MIDI Receive Channel and Receive Filter.
 In Performance Mode, complies with Part Receive Channel and Part Receive Switch.
 In the modes other than Performance Mode, complies with Basic Receive Channel.

[SW12] SYSTEM Receive GM/XG On

*1 Performance Mode only.

3) TRANSMIT/RECEIVE DATA

(3-1) CHANNEL VOICE MESSAGES

(3-1-1) NOTE OFF

STATUS 1000nnnn(8nH) n = 0 ~ 15 CHANNEL NUMBER
 NOTE NUMBER 0kkkkkkk k = 0 (C-2) ~ 127 (G8)
 VELOCITY 0vvvvvvv ignores *v*
 Receive only.

(3-1-2) NOTE ON/OFF

STATUS 1001nnnn(9nH) n = 0 ~ 15 CHANNEL NUMBER
 NOTE NUMBER 0kkkkkkk k = 0 (C-2) ~ 127 (G8)
 VELOCITY 0vvvvvvv(v#0) NOTE ON
 0vvvvvvv(v=0) NOTE OFF

(3-1-3) CONTROL CHANGE

STATUS 1011nnnn(BnH) n = 0 ~ 15 CHANNEL NUMBER
 CONTROL NUMBER 0ccccccc
 CONTROL VALUE 0vvvvvvv

* TRANSMITTED CONTROL NUMBER
 c = 0 BANK SEL MSB ; v = 0,63,127 *3
 c = 32 BANK SEL LSB ; v = 0,1,8,9,24,25,32,40,41,64,65 *3
 c = 1 MODULATION ; v = 0 ~ 127
 c = 0.95 ASSIGNABLE CONTROLLER ; v = 0 ~ 127 *6
 The Sequencer Part will play back all the recorded control change messages.

* RECEIVED CONTROL NUMBER
 c = 0 BANK SEL MSB ; v = 0 ~ 127 *3
 c = 32 BANK SEL LSB ; v = 0 ~ 127 *3
 c = 1 MODULATION ; v = 0 ~ 127
 c = 5 PORTAMENTO TIME ; v = 0 ~ 127 *2
 c = 6 DATA ENTRY MSB ; v = 0 ~ 127 *1
 c = 38 DATA ENTRY LSB ; v = 0 ~ 127 *1
 c = 7 MAIN VOLUME ; v = 0 ~ 127
 c = 10 PAN ; v = 0 ~ 127
 c = 11 EXPRESSION ; v = 0 ~ 127
 c = 31 EG SUSTAIN LEVEL ; v = 0:-64 - 64:0 - 127:+63 *2,*5
 c = 64 SUSTAIN SWITCH ; v = 0-63:OFF , 64-127:ON *2
 c = 65 PORTAMENTO SWITCH ; v = 0-63:OFF , 64-127:ON *2
 c = 66 SOSTENUTO ; v = 0-63:OFF , 64-127:ON *2
 c = 71 HARMONIC CONTENT ; v = 0:-64 - 64:0 - 127:+63
 c = 72 EG RELEASE TIME ; v = 0:-64 - 64:0 - 127:+63 *2
 c = 73 EG ATTACK TIME ; v = 0:-64 - 64:0 - 127:+63
 c = 74 BRIGHTNESS ; v = 0:-64 - 64:0 - 127:+63
 c = 75 EG DECAY TIME ; v = 0:-64 - 64:0 - 127:+63
 c = 91 EFFECT1 DEPTH ; v = 0 ~ 127
 c = 93 EFFECT3 DEPTH ; v = 0 ~ 127
 c = 96 DATA ENTRY INC ; v = 127 *1
 c = 97 DATA ENTRY DEC ; v = 127 *1
 c = 0.95 ASSIGNABLE CONTROLLER ; v = 0 ~ 127 *6
 c = 0.95 ARPEGGIO SW ; v = 0-63:OFF , 64-127:ON *6
 c = 0.95 ARPEGGIO HOLD ; v = 0-63:OFF , 64-127:ON *6

*1 Used only when a value is set using RPN.
 *2 Invalid with Drum Voices.
 *3 Relation between BANK CHANGE and PROGRAM is as follows:

CATEGORY		MSB	LSB	PROGRAM No	Displayed on LCD
Normal Voice	Internal	0	0	0..127	(1..128)
	Drum Voice	127	0	0..1	(1..2)
Normal Voice	Preset 1	63	0	0..127	(1..128)
	Preset 2	63	1	0..127	(1..128)
Plug-in Voice	Internal	63	8	0..127	(1..128)
	External	63	9	0..127	(1..128)
Drum Voice	Plug-in	63	25	0..63	(1..64)
	Preset	63	32	0..7	(1..8)
Performance	Internal	63	40	0..1	(1..2)
	External	63	41	0..1	(1..2)
Performance	Internal	63	64	0..127	(1..128)
	External	63	65	0..63	(1..64)

*5 Transmitted/received only when MODE2 is selected in CONTROL CHANGE MODE.
 *6 The default CONTROL NUMBERS of ASSIGNABLE CONTROLLER are as follows:

FOOT CONTROLLER	11
KNOB 1	16
KNOB 2	17
KNOB A	18
KNOB B	19
KNOB C	20
RIBBON CONTROLLER	22 (Receive only)
CONTROL SLIDER	7
FOOT SWITCH	64
ARPEGGIO HOLD	89 (Receive only)
ARPEGGIO SWITCH	90 (Receive only)

PORTAMENTO TIME sets the time it takes for the pitch to reach the next note played when PORTAMENTO SWITCH is set to on.
 PAN position relatively changes according to the preset value for each voice.
 EFFECT1 DEPTH controls reverb send level.
 EFFECT3 DEPTH controls chorus send level.
 HARMONIC CONTENT adjusts the resonance preset for each voice.
 Setting a value adds to or subtracts from the center value, 64, since it is an offset parameter.
 The larger the value more resonant sound will be produced. The effective range may be narrower than the range you can designate depending on the selected voice.
 The parameters, EG ATTACK TIME, EG DECAY TIME, EG SUSTAIN LEVEL, EG RELEASE TIME adjust the envelopes preset for each voice.
 Setting these values add to or subtract from the center value, 64, since these are offset parameters.
 BRIGHTNESS adjusts the cutoff frequency preset for each voice.
 Setting a value adds to or subtracts from the center value, 64, since it is an offset parameter.
 The smaller the value the cutoff frequency will be lowered. The effective range may be narrower than the range you can designate depending on the selected voice.
 Bank Select will be actually executed when the Program Change message is received.
 Bank Select and Program Change numbers that are not supported by Yamaha will be ignored.

(3-1-4) PROGRAM CHANGE

STATUS 1100nnnn(CnH) n = 0 ~ 15 CHANNEL NUMBER
 PROGRAM NUMBER 0ppppppp p = 0 ~ 127

(3-1-5) CHANNEL AFTER TOUCH

STATUS 1101nnnn(DnH) n = 0 ~ 15 CHANNEL NUMBER
 VALUE 0vvvvvvv v = 0 ~ 127 AFTER TOUCH VALUE

(3-1-6) PITCH BEND CHANGE

STATUS 1110nnnn(EnH) n = 0 ~ 15 CHANNEL NUMBER
 LSB 0vvvvvvv PITCH BEND CHANGE LSB
 MSB 0vvvvvvv PITCH BEND CHANGE MSB
 Transmitted with a resolution of 7 bits.

(3-2) CHANNEL MODE MESSAGES

STATUS 1011nnnn(BnH) n = 0 ~ 15 CHANNEL NUMBER
 CONTROL NUMBER 0ccccccc c = CONTROL NUMBER
 CONTROL VALUE 0vvvvvvv v = DATA VALUE

(3-2-1) ALL SOUNDS OFF (CONTROL NUMBER = 78H, DATA VALUE = 0)

All the sounds currently played including the channel messages such as note-on and hold-on in a certain channel are muted when receiving this message.

(3-2-2) RESET ALL CONTROLLERS (CONTROL NUMBER = 79H, DATA VALUE = 0)

Resets the values set for the following controllers.

PITCH BEND CHANGE 0 (center)
 CHANNEL AFTER TOUCH 0 (minimum)
 MODULATION 0 (minimum)
 EXPRESSION 127 (maximum)
 FOOT CONTROLLER 127 (maximum)
 KNOB 1 0 (center)
 KNOB 2 0 (center)
 SUSTAIN SWITCH 0 (off)
 SOSTENUTO SWITCH 0 (off)
 RPN Not assigned; No change

Doesn't reset the following data:
 PROGRAM CHANGE, BANK SELECT MSB/LSB, VOLUME, PAN,
 HARMONIC CONTENT, SUSTAIN LEVEL, RELEASE TIME, ATTACK TIME, DECAY TIME, BRIGHTNESS
 EFFECT SEND LEVEL 1, EFFECT SEND LEVEL 3, PORTAMENTO SWITCH
 PITCH BEND SENSITIVITY, FINE TUNING, COARSE TUNING
 ASSIGNABLE CONTROLLER

(3-2-3) ALL NOTES OFF (CONTROL NUMBER = 7BH, DATA VALUE = 0)

All the notes currently set to on in certain channel(s) are muted when receiving this message. However, if Sustain or Sostenuto is on, notes will continue sounding until these are turned off.

(3-2-4) OMNI MODE OFF (CONTROL NUMBER = 7CH, DATA VALUE = 0)

Performs the same function as when receiving ALL NOTES OFF.
 Sets VOICE RECEIVE CHANNEL to "OMNI OFF," channel 1.

(3-2-5) OMNI MODE ON (CONTROL NUMBER = 7DH, DATA VALUE = 0)

Performs the same function as when receiving ALL NOTES OFF.
 Sets VOICE RECEIVE CHANNEL to "OMNI ON."

(3-2-6) MONO (CONTROL NUMBER = 7EH, DATA VALUE = 0.16)

Performs the same function as when receiving ALL SOUNDS OFF. If the 3rd byte (mono) is within 0 through 16, the channel will be Mode4(m = 1).
 In VOICE MODE, the mode can be Mode2(m=1) according to VOICE RECEIVE CHANNEL.

(3-2-7) POLY (CONTROL NUMBER = 7FH, DATA VALUE = 0)

Performs the same function as when receiving ALL SOUNDS OFF. The channel will be Mode3.
 In VOICE MODE, the mode can be Mode4 according to VOICE RECEIVE CHANNEL.

(3-3) REGISTERED PARAMETER NUMBER

STATUS 1011nnnn(BnH) n = 0 ~ 15 CHANNEL NUMBER
 LSB 01100100(64H)
 RPN LSB 0ppppppp p = RPN LSB(Refer to the table as shown below)
 MSB 01100101(65H)
 RPN MSB 0qqqqqqq q = RPN MSB(Refer to the table as shown below)
 DATA ENTRY MSB 00000110(06H)
 DATA VALUE 0mmmmmmm m = Data Value
 DATA ENTRY LSB 00100110(26H)
 DATA VALUE 01111111 1 = Data Value

First, designate the parameter using RPN MSB/LSB numbers. Then, set its value with data entry MSB/LSB.

RPN	D.ENTRY			
LSB	MSB	MSB	LSB	PARAMETER NAME DATA RANGE

00H 00H mmH ---	PITCH BEND SENSITIVITY	00H - 18H (0 - 24 semitones)
01H 00H mmH 11H	MASTER FINE TUNE	(mmH,11H)=[00H,00H]-[40H,00H]-[7FH,7FH] (-8192*100/8192) - 0 - (+8192*100/8192)
02H 00H mmH ---	MASTER COARSE TUNE	28H - 40H = 58H (-24 - 0 - +24 semitones)
7FH 7FH --- ---	RPN RESET	RPN numbers will be left not designated. The internal values are not affected.

(3-4) NON-REGISTERED PARAMETER NUMBER

There are no applicable parameters.

(3-5) SYSTEM REAL TIME MESSAGES

(3-5-1) ACTIVE SENSING

STATUS 11111110(FEH)

Transmitted at every 200 msec.
 Once this code is received, the instrument starts sensing. When no status nor data is received for over approximately 350 ms, MIDI receiving buffer will be cleared, and the sounds currently played and the sustain switch are forcibly turned off. In this case, each control data will be reset to a certain value.

(3-6) SYSTEM EXCLUSIVE MESSAGE

(3-6-1) UNIVERSAL NON REALTIME MESSAGE

(3-6-1-1) GENERAL MIDI MODE ON

FOH 7EH 7FH 09H 01H F7H

Received only when SYSTEM Receive GM/XG on is set to on in PERFORMANCE MODE. The Part values will be reset according to the SYSTEM Internal Part settings.

(3-6-1-2)IDENTITY REQUEST(Receive only)

F0H 7EH 0nH 06H 01H F7H ("n" = Device No.However, this instrument receives under "omni.")

(3-6-1-3)IDENTITY REPLY (Transmit only)

F0H 7EH 7FH 06H 02H 43H 00H 41H ddH ddH 00H 00H 00H 7FH F7H
dd:Device Number Code: 23 04

(3-6-2)UNIVERSAL REALTIME MESSAGE

(3-6-2-1) MIDI MASTER VOLUME

F0H 7FH 7FH 04H 01H 11H mmH F7H

Sets the MASTER VOLUME value.
The value "mm" is used to set the master volume (the value "11" should be ignored).

(3-6-3)PARAMETER CHANGE

(3-6-3-1) XG SYSTEM ON

11110000 F0 Exclusive status
01000011 43 YAMAHA ID
0001nnnn 1n device Number
1001100 4C Model ID
0aaaaaaa 0 Address High
0aaaaaaa 0 Address Mid
0aaaaaaa 7E Address Low
0 0 Data
11110111 F7 End of Exclusive

Received only when SYSTEM Receive GM/XG on is set to on in PERFORMANCE MODE. The Part values will be reset according to the SYSTEM Internal Part settings. Be aware that executing this message takes ca. 170ms and that, therefore, a certain interval before executing the following message is needed.

(3-6-3-2) NATIVE PARAMETER CHANGE, REMOTE SWITCH

11110000 F0 Exclusive status
01000011 43 YAMAHA ID
0001nnnn 1n device Number
01100100 64 Model ID
0aaaaaaa aaaaaa Address High
0aaaaaaa aaaaaa Address Mid
0aaaaaaa aaaaaa Address Low
0ddddddd ddddddd Data
| |
11110111 F7 End of Exclusive

For parameters with data size of 2 or more, the appropriate number of data bytes will be transmitted.
See the following MIDI Data Table for Address and Byte Count.
Always received no matter which device number is selected, in the case of REMOTE SWITCH.

(3-6-4)BULK DUMP

11110000 F0 Exclusive status
01000011 43 YAMAHA ID
0000nnnn 0n device Number
01100100 64 Model ID
0bbbbbbb bbbbbbb Byte Count
0bbbbbbb bbbbbbb Byte Count
0aaaaaaa aaaaaa Address High
0aaaaaaa aaaaaa Address Mid
0aaaaaaa aaaaaa Address Low
0 0 Data
| |
0ccccccc ccccccc Check-sum
11110111 F7 End of Exclusive

See the following MIDI Data Table for Address and Byte Count.
The Check sum is the value that results in a value of 0 for the lower 7 bits when the Byte Count, Start Address, Data and Check sum itself are added.

(3-6-5) DUMP REQUEST

11110000 F0 Exclusive status
01000011 43 YAMAHA ID
0010nnnn 2n device Number
01100100 64 Model ID
0aaaaaaa aaaaaa Address High
0aaaaaaa aaaaaa Address Mid
0aaaaaaa aaaaaa Address Low
11110111 F7 End of Exclusive

See the following MIDI Data Table for Address and Byte Count.

(3-6-6) PARAMETER REQUEST

11110000 F0 Exclusive status
01000011 43 YAMAHA ID
0011nnnn 3n device Number
01100100 64 Model ID
0aaaaaaa aaaaaa Address Hig
0aaaaaaa aaaaaa Address Mid
0aaaaaaa aaaaaa Address Low
11110111 F7 End of Exclusive

See the following MIDI Data Table for Address and Byte Count.

4) SYSTEM OVERVIEW (Keyboard, Sequencer and Tone Generator)

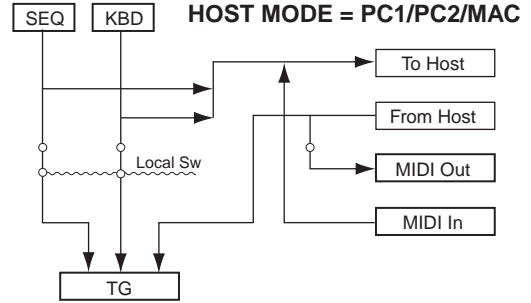
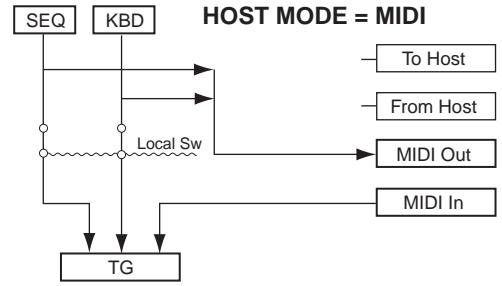

Although three types of note on/note off data, received via MIDI, played by the internal sequencer and played on the keyboard will be distinguished, the other controllers (channel messages) equally affect the entire notes.

ALL SOUNDS OFF clears all the sounds in the specific channel(s) played by both the keyboard and the data via MIDI.
ALL NOTES OFF received via MIDI clears the sounds in the specific channel(s) played via MIDI.

MIDI Data Table

Bank Select

Available Bank Select/Program Change

MSB (HEX)	LSB (HEX)	Program No.	Type	Memory	Description
0	00	0	00	0 - 127	Normal Voice
127	7F	0	00	0 - 1	Drum Voice
63	3F	0	00	0 - 127	Normal Voice
		1	01	0 - 127	Preset 1
		8	08	0 - 127	User(Internal)
		9	09	0 - 127	User(External)
		25	19	0 - 63	Plug-in Voice
		32	20	0 - 7	Drum Voice
		40	28	0 - 1	User(Internal)
		41	29	0 - 1	User(External)
		64	40	0 - 127	Performance
		65	41	0 - 127	User(External)

Plug-in Voice Bank Display

Available Bank Select/Program Change of the Plug-in Boards
(Before selecting a number, a Plug-in Board should be installed and PLG has to be selected in Voice Mode.)

MSB (HEX)	LSB (HEX)	Program No.	Type	LCD Display	Description
63	3F	18 - 19	0 - 63	Internal	PLG_INT
0	00	00 - 7F	0 - 127	XG Normal	LSB = 25H; Plug-in
64	40	00 - 7F	0 - 127	XG SFX	NORM/LLS
126	7E	00 - 7F	0 - 127	XG SFX kit	LLL: Bank LSB
127	7F	00 - 7F	0 - 127	XG Drum kit	KIT/SFX
***	**	00 - 7F	0 - 127	others	KIT/DRM
					MMM: Bank MSB, LLL: Bank LSB

Only the banks that can be received by Plug-in Board are shown.

<Table1>

Parameter Base Address

Parameter Block	Top Address			Description
	H	M	L	
SYSTEM	00	00	00	System
	00	10	00	Plug-in Board Native System
	00	20	00	Master EQ
	00	70	00	Panel Knob
REMOTE SWITCH	0A	00	00	Remote Switch
BULK CONTROL	0E	00	00	Header
	0F	00	00	Footer
PERFORMANCE COMMON	30	00	00	Performance Common
PERFORMANCE PART	31	00	00	Part1
	31	0F	00	Part16
PERFORMANCE ZONE	31	61	00	Plug-in Part
	32	00	00	Zone1
VOICE COMMON	32	03	00	Zone4
	40	00	00	Common
	40	01	00	Reverb
	40	02	00	Chorus
	40	03	00	Insertion 1
VOICE ELEMENT GROUP1	40	04	00	Insertion 2
	40	05	00	Controller
	40	06	00	LFO
	40	70	00	Extra
VOICE ELEMENT GROUP2	41	ee	00	ee : Element No.
	42	ee	00	ee : Element No.
	43	ee	00	ee : Element No.
	44	ee	00	ee : Element No.
KIT COMMON (DRUM VOICE)	46	00	00	Common
	46	01	00	Reverb
	46	02	00	Chorus
	46	03	00	Insertion 1
	46	04	00	Insertion 2
	46	05	00	Controller
	46	70	00	Extra
	47	ee	00	ee : Element No.
KIT ELEMENT GROUP1	48	ee	00	ee : Element No.
	49	ee	00	ee : Element No.
	4A	ee	00	ee : Element No.
	4A	ee	00	ee : Element No.
VOICE PLUGIN	4C	00	00	Common
	4C	01	00	Reverb
	4C	02	00	Chorus
	4C	03	00	Insertion 1
	4C	05	00	Controller
	4C	10	00	Plug-in Element
	4C	20	00	Native
	4C	70	00	Extra

< Table 2 >

Bulk Dump Block

- "Top Address" indicates the top address of each block designated by bulk dump operation.
- "Byte Count" indicates the data size contained in each block designated by bulk dump operation.
- All blocks, from Bulk Header through Bulk Footer, of PERFORMANCE/VOICE can be received even though they are not sent in order and/or not all of them are sent. However, squeezing a different block in those blocks causes the operation invalid.
- To execute 1 Performance/1 Voice bulk dump request, designate its corresponding Bulk Header address.
- For the information about "mm" and "nn" shown in the following list, refer to MIDI PARAMETER CHANGE TABLE (BULK CONTROL) below.

Parameter Block	Description	Byte Count		Top Address			
		Dec	Hex	H	M	L	
SYSTEM	System	60	3C	00	00	00	
	Plug-in Board Native System	32	20	00	10	00	
	Master EQ (for Voice Mode)	20	14	00	20	00	
PERFORMANCE	COMMON	Bulk Header	0	00	0E	mm	nn
		Common	68	44	30	00	00
		Reverb	24	18	30	01	00
		Chorus	25	19	30	02	00
		Master EQ	20	14	30	10	00
	Native (for InsEF Plug-in)	68	44	30	20	00	
	PART	Part1	37	25	31	00	00
		:	16 Blocks	:	:	:	:
	PLUG-IN PART	Part16	37	25	31	0F	00
		Plug-in Part	37	25	31	61	00
MASTER KEYBOARD ZONE	Zone1	16	10	32	00	00	
	:	4 Blocks	:	:	:	:	
	Zone4	16	10	32	03	00	
	Bulk Footer	0	00	0F	mm	nn	
VOICE (NORMAL)	COMMON	Bulk Header	0	00	0E	mm	nn
		Extra	56	38	40	70	00
		Common	13	0D	40	00	00
		Reverb	24	18	40	01	00
		Chorus	25	19	40	02	00
		Insertion 1(S)	22	16	40	03	00
	Insertion 2(L)	34	22	40	04	00	
	Controller	30	1E	40	05	00	
	LFO	14	0E	40	06	00	
	ELEMENT 1	Oscillator	13	0D	41	00	00
Amplitude		29	1D	41	00	20	
Pitch		27	1B	42	00	00	
Filter		48	30	43	00	00	
EQ		8	08	44	00	00	
LFO		6	06	44	00	40	
ELEMENT 2	Oscillator	13	0D	41	01	00	
	Amplitude	29	1D	41	01	20	
	Pitch	27	1B	42	01	00	
	Filter	48	30	43	01	00	
	EQ	8	08	44	01	00	
	LFO	6	06	44	01	40	
ELEMENT 3	Oscillator	13	0D	41	02	00	
	Amplitude	29	1D	41	02	20	
	Pitch	27	1B	42	02	00	
	Filter	48	30	43	02	00	
	EQ	8	08	44	02	00	
	LFO	6	06	44	02	40	
ELEMENT 4	Oscillator	13	0D	41	03	00	
	Amplitude	29	1D	41	03	20	
	Pitch	27	1B	42	03	00	
	Filter	48	30	43	03	00	
	EQ	8	08	44	03	00	
	LFO	6	06	44	03	40	
Bulk Footer	0	00	0F	mm	nn		
VOICE (DRUM)	COMMON	Bulk Header	0	00	0E	mm	nn
		Extra	56	38	46	70	00
		Common	7	07	46	00	00
		Reverb	24	18	46	01	00
		Chorus	25	19	46	02	00
		Insertion 1(S)	22	16	46	03	00
	Insertion 2(L)	34	22	46	04	00	
	Controller	30	1E	46	05	00	
	KEY C 0	Oscillator	18	12	47	00	00
		Amplitude	12	0C	47	00	20
Pitch		3	03	48	00	00	
Filter		8	08	49	00	00	
EQ		8	08	4A	00	00	
:	73 Blocks	:	:	:	:		
KEY C 6	Oscillator	18	12	47	48	00	
	Amplitude	12	0C	47	48	20	
	Pitch	3	03	48	48	00	
	Filter	8	08	49	48	00	
	EQ	8	08	4A	48	00	
Bulk Footer	0	00	0F	mm	nn		

VOICE (PLUG-IN)	Bulk Header	0 00	0E	mm	nn
COMMON	Extra	56 38	4C	70	00
	Common	13 0D	4C	00	00
	Reverb	24 18	4C	01	00
	Chorus	25 19	4C	02	00
	Insertion 1(S)	22 16	4C	03	00
	Controller	10 0A	4C	05	00
	Plug-in Element	35 23	4C	10	00
	Native	68 44	4C	20	00
	Bulk Footer	0 00	0F	mm	nn

Parameter Change

F0, 43, 1n, id, ah, am, al, dt, ... F7

n: Device Number
id: Model ID
ah: Parameter Address High
am: Parameter Address Middle
al: Parameter Address Low
dt: Data

Parameter Request

F0, 43, 3n, id, ah, am, al F7

n: Device Number
id: Model ID
ah: Parameter Address High
am: Parameter Address Middle
al: Parameter Address Low

Bulk Dump

F0, 43, 0n, id, bh, bl, ah, am, al, dt, ..., cc, F7

n: Device Number
id: Model ID
bh: Byte Count High
bl: Byte Count Low
ah: Parameter Address High
am: Parameter Address Middle
al: Parameter Address Low
dt: Data
cc: Check Sum of Data

Bulk Dump Request

F0, 43, 2n, id, ah, am, al, F7

n: Device Number
id: Model ID
ah: Parameter Address High
am: Parameter Address Middle
al: Parameter Address Low

<Table 3>

MIDI PARAMETER CHANGE TABLE (SYSTEM)

Address	Size	Data Range(HEX)	Parameter Name	Description	Default(HEX)	Notes
00 00	00 1	00 - 7F	Master Volume	0 - 127	7F	MIDI Master Volume
01	1	28 - 58	Master Note Shift	-24 - +24[semitones]	40	
02	4	00 - 0F	Master Tune	-102.4 - +102.3[cent]	40	00 04 00 00 MIDI Master Tuning
		00 - 0F		1st bit3-0 → bit15-12		
		00 - 0F		2nd bit3-0 → bit11-8		
		00 - 0F		3rd bit3-0 → bit7-4		
		00 - 0F		4th bit3-0 → bit3-0		
06	1	00 - 01	Controller Reset	hold, reset	00	
07	1	35 - 4B	Master Transpose	-11 - +11[semitones]	40	
08	1	3D - 43	Master Octave Shift	-3 - +3	40	
09	1	00 - 01	Local Switch	off, on	01	
0A	1	00 - 10,7F	Basic Receive Channel	1 - 16,omni,off	00	
0B	1	00 - 0F,7F	Keyboard Transmit Channel	1 - 16,off	00	
0C	1	00 - 01	MIDI Sync	int,MIDI	00	
0D	1	00 - 01	MIDI Control	off, on	01	
0E	1	00 - 01	Plug-in Board MIDI Sync/Control	off, on	00	
10	1		reserved		02	
11	1	00 - 03	BC Curve (for TG)	thru, soft, hard, wide	00	
12	1	00 - 04	Keyboard Velocity Curve	norm, soft, hard, wide, fixed	00	
13	1	01 - 7F	Keyboard Fixed Velocity	1 - 127	40	
14	1	00 - 01	Receive GM/XG On	off, on	01	
15	1	00 - 03	Receiver/Transmit Bank Select	off, all, part, perform	01	
16	1	00 - 01	Receive Program Change	off, on	00	
17	1	00 - 01	MIDI Control Mode	mode1, mode2	00	
18	1	00 - 07	Thru Port	1 - 8	00	
19	1		reserved		00	
1A	1	00 - 01	Effect Bypass Reverb	off, on	01	
1B	1	00 - 01	Effect Bypass Chorus	off, on	01	
1C	1	00 - 01	Effect Bypass Insertion	off, on	00	
1D	1		reserved		00	
1E	1	00 - 02	GM/XG Receive Mode	all-part, layer-part, all-off	02	
1F	1	00 - 03	Power on Mode	Performance, Voice(INT), Voice(PRE1), last	00	
20	1		reserved		00	
21	1		reserved		00	
22	1		reserved		00	
23	1		reserved		00	
24	1		reserved		00	
25	4		reserved		00	
29	1	00 - 5F	Scene Control Number	off, 1 - 95	0E	
2A	1	00 - 33	Knob A Destination	off, 1 - 51	01	
2B	1	00 - 33	Knob B Destination	off, 1 - 51	07	
2C	1	00 - 33	Knob C Destination	off, 1 - 51	0D	
2D	1	00 - 5F	Knob A Control Number	off, 1 - 95	12	
2E	1	00 - 5F	Knob B Control Number	off, 1 - 95	13	
2F	1	00 - 5F	Knob C Control Number	off, 1 - 95	14	
30	1	00 - 01	FV Assign	volume, express	01	
31	1	00 - 64	FS Assign	off, 1 - 95, Arp Sw, Arp Hold, SMF Play, PC Inc, PC Dec	58	
32	1	00 - 5F	ARP Switch Control Number	off, 1 - 95	5A	
33	1	00 - 5F	ARP Hold Control Number	off, 1 - 95	59	
34	1	00 - 01	ARP MIDI Out Switch	off, on	00	for Voice Mode
35	1	00 - 0F	ARP MIDI Out Channel	1 - 16	00	
36	1	00 - 5F	KN1 Control Number	off, 1 - 95	10	
37	1	00 - 5F	KN2 Control Number	off, 1 - 95	11	
38	1	00 - 5F	BC Control Number	off, 1 - 95	02	
39	1	00 - 5F	FC Control Number	off, 1 - 95	04	
3A	1	00 - 5F	RB Control Number	off, 1 - 95	16	

TOTAL SIZE = 60 3C (HEX)

	10	16	00 - 7F	Plug-in Native System Parameter	depends on Plug-in Board	depends on Plug-in Board
TOTAL SIZE =	32	20	(HEX)			
00 20	00	1	34 - 4C	EQ Gain1	-12 - +12[dB]	40 for Voice Mode
01	1	04 - 28	EQ Frequency1	32 - 2000[Hz]	0C	
02	1	01 - 78	EQ Q1	0.1 - 12.0	07	
03	1	00 - 01	EQ Shape1	shelv, peak	00	
04	1	34 - 4C	EQ Gain2	-12 - +12[dB]	40	
05	1	0E - 36	EQ Frequency2	100 - 10.0[kHz]	1C	
06	1	01 - 78	EQ Q2	0.1 - 12.0	07	
	1		NOT USED			
08	1	34 - 4C	EQ Gain3	-12 - +12[dB]	40	
09	1	0E - 36	EQ Frequency3	100 - 10.0[kHz]	22	
0A	1	01 - 78	EQ Q3	0.1 - 12.0	07	
	1		NOT USED			
0C	1	34 - 4C	EQ Gain4	-12 - +12[dB]	40	
0D	1	0E - 36	EQ Frequency4	100 - 10.0[kHz]	2E	
0E	1	01 - 78	EQ Q4	0.1 - 12.0	07	
	1		NOT USED			
10	1	34 - 4C	EQ Gain5	-12 - +12[dB]	40	
11	1	1C - 3A	EQ Frequency5	0.5 - 16.0[kHz]	34	
12	1	01 - 78	EQ Q5	0.1 - 12.0	07	
13	1	00 - 01	EQ Shape5	shelv, peak	00	

TOTAL SIZE = 20 14 (HEX)

MIDI PARAMETER CHANGE TABLE (BULK CONTROL)

Address	Size	Data Range(HEX)	Parameter Name	Description	Default(HEX)	Notes
0E08	nn	0	-	Bulk Header	Normal Voice INT (nn = 0 - 127)	-
09	nn	0	-	Normal Voice EXT (nn = 0 - 127)	-	-
0F	nn	0	-	Normal Voice Edit Buffer (nn = 0)	-	-
19	nn	0	-	Plug-in Voice PLG (nn = 0 - 63)	-	-
1F	nn	0	-	Plug-in Voice Edit Buffer (nn = 0)	-	-
28	nn	0	-	Drum Voice INT (nn = 0 - 1)	-	-
29	nn	0	-	Drum Voice EXT (nn = 0 - 1)	-	-
2F	nn	0	-	Drum Voice Edit Buffer (nn = 0)	-	-
40	nn	0	-	Performance INT (nn = 0 - 127)	-	-
41	nn	0	-	Performance EXT (nn = 0 - 63)	-	-
4F	nn	0	-	Performance Edit Buffer (nn = 0)	-	-
0F08	nn	0	-	Bulk Footer	Normal Voice INT (nn = 0 - 127)	-
09	nn	0	-	Normal Voice EXT (nn = 0 - 127)	-	-
0F	nn	0	-	Normal Voice Edit Buffer (nn = 0)	-	-
19	nn	0	-	Plug-in Voice PLG (nn = 0 - 63)	-	-
1F	nn	0	-	Plug-in Voice Edit Buffer (nn = 0)	-	-
28	nn	0	-	Drum Voice INT (nn = 0 - 1)	-	-
29	nn	0	-	Drum Voice EXT (nn = 0 - 1)	-	-
2F	nn	0	-	Drum Voice Edit Buffer (nn = 0)	-	-
40	nn	0	-	Performance INT (nn = 0 - 127)	-	-
41	nn	0	-	Performance EXT (nn = 0 - 63)	-	-
4F	nn	0	-	Performance Edit Buffer (nn = 0)	-	-

<Table 4>

MIDI PARAMETER CHANGE TABLE (REMOTE SWITCH)

Address	Size	Data Range(HEX)	Parameter Name	Description	Default(HEX)	Notes
0A00	10	f	00-01	PERFORM	off.on	--
11	1	00-01	VOICE	off.on	--	
12	1	00-01	SEQ PLAY	off.on	--	
13	1	00-01	UTILITY	off.on	--	
14	1	00-01	CARD	off.on	--	
15	1	00-01	PLAY/STOP	off.on	--	
16	1	00-01	EDIT	off.on	--	
17	1	00-01	JOB	off.on	--	
18	1	00-01	SHIFT	off.on	--	
19	1	00-01	EF BYPASS	off.on	--	
1A	1	00-01	MASTER KEYBOARD	off.on	--	
1B	1	00-01	DEC/NO	off.on	--	
1C	1	00-01	INC/YES	off.on	--	
1D	1	00-01	EXIT	off.on	--	
1E	1	00-01	ENTER	off.on	--	
1F	1	00-01	STORE	off.on	--	
20	1	00-01	PRE1	off.on	--	
21	1	00-01	PRE2	off.on	--	
22	1	00-01	INT	off.on	--	
23	1	00-01	EXT	off.on	--	
25	1	00-01	PLG	off.on	--	
26	1		reserved		--	
27	f	00-01	QUICK ACCESS	off.on	--	
28	f	00-01	A	off.on	--	
29	f	00-01	B	off.on	--	
2A	f	00-01	C	off.on	--	
2B	f	00-01	D	off.on	--	
2C	f	00-01	E	off.on	--	
2D	f	00-01	F	off.on	--	
2E	f	00-01	G	off.on	--	
2F	f	00-01	H	off.on	--	
30	f	00-01	1	off.on	--	
31	f	00-01	2	off.on	--	
32	f	00-01	3	off.on	--	
33	f	00-01	4	off.on	--	
34	f	00-01	5	off.on	--	
35	f	00-01	6	off.on	--	
36	f	00-01	7	off.on	--	
37	f	00-01	8	off.on	--	
38	f	00-01	9	off.on	--	
39	f	00-01	10	off.on	--	
3A	f	00-01	11	off.on	--	
3B	f	00-01	12	off.on	--	
3C	f	00-01	13	off.on	--	
3D	f	00-01	14	off.on	--	
3E	f	00-01	15	off.on	--	
3F	f	00-01	16	off.on	--	

<Table 5>

MIDI PARAMETER CHANGE TABLE (PERFORMANCE COMMON)

Address	Size	Data Range(HEX)	Parameter Name	Description	Default(HEX)	Notes
300000	00	1	20-7E	Performance Name1	32_126(ASCII)	l
300001	01	1	20-7E	Performance Name2	32_126(ASCII)	n
300002	02	1	20-7E	Performance Name3	32_126(ASCII)	i
300003	03	1	20-7E	Performance Name4	32_126(ASCII)	t
300004	04	1	20-7E	Performance Name5	32_126(ASCII)	
300005	05	1	20-7E	Performance Name6	32_126(ASCII)	P
300006	06	1	20-7E	Performance Name7	32_126(ASCII)	e
300007	07	1	20-7E	Performance Name8	32_126(ASCII)	r
300008	08	1	20-7E	Performance Name9	32_126(ASCII)	f
300009	09	1	20-7E	Performance Name10	32_126(ASCII)	
30000A	0A	1		reserved		
30000B	0B	1		reserved		
30000C	0C	1	00-16	Performance Category	00_22(-_Sq)	00(-)
30000E	0E	1	00-02	Master Keyboard Mode	split4zone.laver	01
30000F	0F	1	00-7F	Master Keyboard Split Point	C-2_G8	32
300010	10	1	00-10	Layer Channel	1_16.BasicCh	10
300011	11	1	00-01	ARP MIDI Out Switch	off.on	00
300012	12	1	00-10	ARP MIDI Out Channel	1_16.kbd-ch	00
300013	13	1	00-7F	ARP Type	UpOct1 - GateCut3	00
300014	14	1	00-01	ARP Switch	off.on	00
300015	15	1	00-02	ARP Hold	sync-off.off.on	01
300016	16	1	00-06	ARP Unit Multiply	85%,86%,75%,100%,133%,150%,200%	03
300017	17	1	00-7F	ARP Note Limit Low	C-2_G8	7F
300018	18	1	00-7F	ARP Note Limit High	C-2_G8	00
300019	19	1	00-02	ARP Key Mode	sort.thru.direct	01
30001A	1A	1	00-01	ARP Vel Mode	original.thru	01
30001B	2	0000-00C8	ARP Velocity Rate MSB	ARP Velocity Rate LSB	0...200%	64
30001D	2	0000-00C8	ARP Gate Time Rate MSB	ARP Gate Time Rate LSB	0...200%	64
30001F	2	0019-012C	ARP Tempo MSB	ARP Tempo LSB	25.300	78
300021	1	01-7F	QED Pan		L63_C_R63	40
300022	1		reserved			40
300023	1	00-7F	QED Chorus Control		-64,+63	40
300024	1	00-7F	QED Release Time		-64,+63	40
300025	1	00-7F	QED Sustain Level		-64,+63	40
300026	1	00-7F	QED Portamento Time		-64,+63	40
300027	1	00-01	QED Portamento Switch		off.on	00
300028	1	00-7F	QED KnobA		-64,+63	40
300029	1	00-7F	QED KnobB		-64,+63	40
30002A	1	00-7F	QED KnobC		-64,+63	40
30002B	1	00-7F	QED/Scene 1 Knob1		-64,+63	40
30002C	1	00-7F	QED/Scene 1 Knob2		-64,+63	40
30002D	1	00-7F	QED/Scene 1 Cutoff Frequency		-64,+63	40
30002E	1	00-7F	QED/Scene 1 Resonance		-64,+63	40
30002F	1	00-7F	QED/Scene 1 Attack Time		-64,+63	40
300030	1	00-7F	QED/Scene 1 Decay Time		-64,+63	40
300031	1	00-7F	Scene 2 Knob1		-64,+63	40
300032	1	00-7F	Scene 2 Knob2		-64,+63	40
300033	1	00-7F	Scene 2 Cutoff Frequency		-64,+63	40
300034	1	00-7F	Scene 2 Resonance		-64,+63	40
300035	1	00-7F	Scene 2 Attack Time		-64,+63	40
300036	1	00-7F	Scene 2 Decay Time		-64,+63	40
300037	1	00-7F	Scene Control		0_127	00
300038	1	00-7F	QED Volume		0_127	7F
300039	1	00-7F	QED Reverb Send		0_127	7F
30003A	1	00-7F	QED Chorus Send		0_127	7F
30003B	1	00-5F	KN1 Control Number		off.1 - 95	10
30003C	1	00-5F	KN2 Control Number		off.1 - 95	11
30003D	1	00-5F	BC Control Number		off.1 - 95	02
30003E	1	00-5F	FC Control Number		off.1 - 95	04
30003F	1	00-5F	RB Control Number		off.1 - 95	16
300040	1	00-01	RB Mode		hold/reset	00
300041	1	00-7F	Insertion Effect Part for Normal		0 - 15; Part1 ... 16 127; off	00
300042	1	61-7F	Insertion Effect Part for Plug-in		97; PartPL 127; off	60
300043	1	00-7F	Insertion Plug-in Part		0 - 15; Part1 ... 16 127; off	7F

TOTAL SIZE = 68 44 (HEX)

Address	Size	Data Range(HEX)	Parameter Name	Description	Default(HEX)	Notes
300100	2	00-7F	Reverb Type MSB	Refer to Effect Parameter List		Depends On Effect Type
		00-7F	Reverb Type LSB			
300102	2	00-7F	Reverb Parameter 1 MSB	#	#	
		00-7F	Reverb Parameter 1 LSB			
300104	2	00-7F	Reverb Parameter 2 MSB	#	#	
		00-7F	Reverb Parameter 2 LSB			
300106	2	00-7F	Reverb Parameter 3 MSB	#	#	
		00-7F	Reverb Parameter 3 LSB			
300108	2	00-7F	Reverb Parameter 4 MSB	#	#	
		00-7F	Reverb Parameter 4 LSB			
30010A	2	00-7F	Reverb Parameter 5 MSB	#	#	
		00-7F	Reverb Parameter 5 LSB			
30010C	2	00-7F	Reverb Parameter 6 MSB	#	#	
		00-7F	Reverb Parameter 6 LSB			
30010E	2	00-7F	Reverb Parameter 7 MSB	#	#	
		00-7F	Reverb Parameter 7 LSB			
300110	2	00-7F	Reverb Parameter 8 MSB	#	#	
		00-7F	Reverb Parameter 8 LSB			
300112	2	00-7F	Reverb Parameter 9 MSB	#	#	
		00-7F	Reverb Parameter 9 LSB			
300114	2	00-7F	Reverb Parameter 10 MSB	#	#	
		00-7F	Reverb Parameter 10 LSB			
300116	1	00-7F	Reverb Return		--dB...0dB...+6dB(0...96...127)	7F
300117	1	01-7F	Reverb Pan		L63_C_R63	40

TOTAL SIZE = 24 18 (HEX)

Address	Size	Data Range(HEX)	Parameter Name	Description	Default(HEX)	Notes
30 02 00	2	00-7F	Chorus Type MSB	Refer to Effect Parameter List		Depends On Effect Type
		00-7F	Chorus Type LSB			
30 02 02	2	00-7F	Chorus Parameter 1 MSB	"	"	
		00-7F	Chorus Parameter 1 LSB			
30 02 04	2	00-7F	Chorus Parameter 2 MSB	"	"	
		00-7F	Chorus Parameter 2 LSB			
30 02 06	2	00-7F	Chorus Parameter 3 MSB	"	"	
		00-7F	Chorus Parameter 3 LSB			
30 02 08	2	00-7F	Chorus Parameter 4 MSB	"	"	
		00-7F	Chorus Parameter 4 LSB			
30 02 0A	2	00-7F	Chorus Parameter 5 MSB	"	"	
		00-7F	Chorus Parameter 5 LSB			
30 02 0C	2	00-7F	Chorus Parameter 6 MSB	"	"	
		00-7F	Chorus Parameter 6 LSB			
30 02 0E	2	00-7F	Chorus Parameter 7 MSB	"	"	
		00-7F	Chorus Parameter 7 LSB			
30 02 10	2	00-7F	Chorus Parameter 8 MSB	"	"	
		00-7F	Chorus Parameter 8 LSB			
30 02 12	2	00-7F	Chorus Parameter 9 MSB	"	"	
		00-7F	Chorus Parameter 9 LSB			
30 02 14	2	00-7F	Chorus Parameter 10 MSB	"	"	
		00-7F	Chorus Parameter 10 LSB			
30 02 16	1	00-7F	Chorus Return	-->dB_0dB+6dB(0_96_127)	7F	
30 02 17	1	01-7F	Chorus Pan	L63_C_R63	40	
30 02 18	1	00-7F	Send Chorus To Reverb	-->R_0dB(0_127)	00	
TOTAL SIZE = 25 19 (HEX)						

30 05 01	2	00	Controller Set1 Destination MSB	0-29	00	
		00-1D	Controller Set1 Destination LSB			
30 05 03	1	00-7F	Controller Set1 Depth	-64 +63	40	
30 05 04	1		reserved			
30 05 05	1	00-09	Controller Set2 Source	PB, MW1, ..., AT, FC, FS, RB, BC, KN1, KN2	00	
30 05 06	2	00	Controller Set2 Destination MSB	0-29	00	
		00-1D	Controller Set2 Destination LSB			
30 05 08	1	00-7F	Controller Set2 Depth	-64 +63	40	
30 05 09	1		reserved		00	
TOTAL SIZE = 10 0A (HEX)						

30 10 00	1	34-4C	EQ Gain1	-12 +12dB	40	
30 10 01	1	04-28	EQ Frequency1	32-2000[Hz]	0C	
30 10 02	1	01-78	EQ Q1	0.1-12.0	07	
30 10 03	1	00-01	EQ Shape1	shelvy,peak	00	
30 10 04	1	34-4C	EQ Gain2	-12 +12dB	40	
30 10 05	1	0E-36	EQ Frequency2	100-10.0kHz	1C	
30 10 06	1	01-78	EQ Q2	0.1-12.0	07	
	1		Not Used			
30 10 08	1	34-4C	EQ Gain3	-12 +12dB	40	
30 10 09	1	0E-36	EQ Frequency3	100-10.0kHz	22	
30 10 0A	1	01-78	EQ Q3	0.1-12.0	07	
	1		Not Used			
30 10 0C	1	34-4C	EQ Gain4	-12 +12dB	40	
30 10 0D	1	0E-36	EQ Frequency4	100-10.0kHz	2E	
30 10 0E	1	01-78	EQ Q4	0.1-12.0	07	
	1		Not Used			
30 10 10	1	34-4C	EQ Gain5	-12 +12dB	40	
30 10 11	1	1C-3A	EQ Frequency5	0.5-16.0kHz	34	
30 10 12	1	01-78	EQ Q5	0.1-12.0	07	
30 10 13	1	00-01	EQ Shape5	shelvy,peak	00	
TOTAL SIZE = 20 14 (HEX)						

30 20 00	16	00-7F	Plug-in Board Native System Parameter	(for InsEF Plug-in)		depends on Plug-in Board
30 20 10	48	00-7F	Plug-in Board Native Parameter	(for InsEF Plug-in)		depends on Plug-in Board
30 20 40	3	00-7F	Plug-in Board Type MSB	(for InsEF Plug-in)		depends on Plug-in Board
		00-7F	Plug-in Board Type LSB			
		00-7F	Plug-in Board Version Number			
43	1	00-7F	reserved			
TOTAL SIZE = 68 44 (HEX)						

<Table 6>
MIDI PARAMETER CHANGE TABLE (PERFORMANCE PART)

Address	Size	Data Range(HEX)	Parameter Name	Description	Default(HEX)	Notes
31 pp 00	1	00-7F	Bank Select MSB	0-127	00	
31 pp 01	1	00-7F	Bank Select LSB	0-127	00	
31 pp 02	1	00-7F	Program Number	1-128	00	
31 pp 03	1	00-0F,7F	Receive Channel	1_16,off(7F)		Part No.
31 pp 04	1	00-01	Part Mode	mono,poly	01	Part1-16_PL
31 pp 05	1	01-7F	Velocity Limit Low	1-127	01	Part1-16_PL
31 pp 06	1	01-7F	Velocity Limit High	1-127	7F	Part1-16_PL
31 pp 07	1	00-7F	Note Limit Low	C-2_G8	00	Part1-16_PL
31 pp 08	1	00-7F	Note Limit High	C-2_G8	7F	Part1-16_PL
31 pp 09	1	10-58	Pitch Bend Range Upper	-48 +24	40	Part1-16_PL
31 pp 0A	1	10-58	Pitch Bend Range Lower	-48 +24	40	Part1-16_PL
31 pp 0B	1	00-7F	Velocity Sense Depth	0-127	40	Part1-16_PL
31 pp 0C	1	00-7F	Velocity Sense Offset	0-127	40	Part1-16_PL
31 pp 0D	1	00-7F	Volume	0-127	64	
31 pp 0E	1	01-7F	Pan	L63_C_R63	40	
31 pp 0F	1		reserved			
31 pp 10	2	00-0F	Detune MSB	-12.8 +12.7[Hz]		08 00 (80)
		00-0F	Detune LSB	1st bit3-0 → bit7-4 2nd bit3-0 → bit3-0		
31 pp 12	1	00-7F	Reverb Send	0-127	28	
31 pp 13	1	00-7F	Chorus Send	0-127	00	
31 pp 14	1		reserved		00	
31 pp 15	1	28-58	Note Shift	-24 +24[semitones]	00	Part1-16_PL
31 pp 16	1	00-7F	Filter Cutoff Frequency	-64 +63	40	Part1-16_PL
31 pp 17	1	00-7F	Filter Resonance/Width	-64 +63	40	Part1-16_PL
31 pp 18	1		reserved		40	
31 pp 19	1	00-01	Portamento Switch	off,on	00	Part1-16_PL
31 pp 1A	1	00-7F	Portamento Time	0-127	40	Part1-16_PL
31 pp 1B	1	00-01	Portamento Mode	fingered,fulltime	00	Part1-16_PL
31 pp 1C	1		reserved		00	
31 pp 1D	1	00-7F	Layer Sw	bit0: Layer Sw off/on bit1: Arpeggio Sw off/on bit2: off/on Control Change bit3: off/on Bank Select bit4: off/on Program Change bit5: off/on AT bit6: off/on PB	7C	Part1-on, Other/off Part1-16_PL
31 pp 1E	1	00-7F	Receive Volume/Expression	bit0: off/on Volume/Expression bit1: off/on Pan bit2: reserved bit3: off/on Sustain/Sostenute bit4: reserved bit5: off/on MW bit6: reserved	7F	
31 pp 1F	1	00-7F	Receive FC	bit0: off/on FC bit1: off/on FS bit2: off/on RB bit3: off/on BC bit4: off/on KN1 bit5: off/on KN2 bit6: reserved	7F	
31 pp 20	1	00-7F	AEG Decay2 Level (EG Sustain Level)	-64 +63	40	Part1-16
31 pp 21	1	00-7F	AEG Attack Time (EG Attack Time)	-64 +63	40	Part1-16_PL
31 pp 22	1		reserved		40	
31 pp 23	1	00-7F	AEG Decay2 Time (EG Decay Time)	-64 +63	40	Part1-16_PL
31 pp 24	1	00-7F	AEG Release Time (EG Release Time)	-64 +63	40	Part1-16_PL
TOTAL SIZE = 37 25 (HEX)						

pp = part number
00-0F
61 Part 1-16
Part Plug-in

<Table 7>
MIDI PARAMETER CHANGE TABLE (MASTER KEYBOARD ZONE)

Address	Size	Data Range(HEX)	Parameter Name	Description	Default(HEX)	Notes
32 nn 00	1	00-3F	Transmit Channel, MIDI/TG Switch	bit0-3: Ch1_16 bit4: MIDI off/on bit5: TG off/on		Zone1-30, Other-00
32 nn 01	1	3D-43	Transpose (Octave)	-3_+3	40	
32 nn 02	1	35-4B	Transpose (Semitone)	-11_+11[semitones]	40	
32 nn 03	1	00-7F	Note Limit Low	C-2_G8	00	
32 nn 04	1	00-7F	Note Limit High	C-2_G8	07	
32 nn 05	1		reserved		7F	
32 nn 06	1		reserved			
32 nn 07	1	00-7F	MIDI Volume	0_127	64	
32 nn 08	1	00-7F	MIDI Pan	0_127	40	
32 nn 09	1	00-7F	MIDI Bank MSB	0_127	00	
32 nn 0A	1	00-7F	MIDI Bank LSB	0_127	00	
32 nn 0B	1	00-7F	MIDI Program Number	1_128	00	
32 nn 0C	1	00-7F	Transmit Volume/FV	bit0: off/on FV (Volume/Expression) bit1: off/on Pan bit2: off/on Sustain bit3: off/on Bank Select bit4: off/on Program Change bit5: off/on AT bit6: off/on PB	7F	
32 nn 0D	1	00-7F	Transmit FC	bit0: off/on FC bit1: off/on FS bit2: off/on RB bit3: off/on BC bit4: off/on MW bit5: off/on Assignable Knob(A/B/C) bit6: off/on Assignable Knob1,2	7F	
32 nn 0E	1	00-5F	Control Slider Control Number	off,1-95	07	
32 nn 0F	1		reserved		00	
TOTAL SIZE = 16 10 (HEX)						

nn = zone number 00-03

Address	Size	Data Range(HEX)	Prameter Name	Description	Default(HEX)	Notes
46 03 00	2	00 - 7F	Insertion-1 Type MSB	Refer to Effect Parameter List	0000	
		00 - 7F	Insertion-1 Type LSB			
46 03 02	2	00 - 7F	Insertion-1 Parameter1 MSB	#		Depends On Effect Type
		00 - 7F	Insertion-1 Parameter1 LSB			
46 03 04	2	00 - 7F	Insertion-1 Parameter2 MSB	#		
		00 - 7F	Insertion-1 Parameter2 LSB			
46 03 06	2	00 - 7F	Insertion-1 Parameter3 MSB	#		
		00 - 7F	Insertion-1 Parameter3 LSB			
46 03 08	2	00 - 7F	Insertion-1 Parameter4 MSB	#		
		00 - 7F	Insertion-1 Parameter4 LSB			
46 03 0A	2	00 - 7F	Insertion-1 Parameter5 MSB	#		
		00 - 7F	Insertion-1 Parameter5 LSB			
46 03 0C	2	00 - 7F	Insertion-1 Parameter6 MSB	#		
		00 - 7F	Insertion-1 Parameter6 LSB			
46 03 0E	2	00 - 7F	Insertion-1 Parameter7 MSB	#		
		00 - 7F	Insertion-1 Parameter7 LSB			
46 03 10	2	00 - 7F	Insertion-1 Parameter8 MSB	#		
		00 - 7F	Insertion-1 Parameter8 LSB			
46 03 12	2	00 - 7F	Insertion-1 Parameter9 MSB	#		
		00 - 7F	Insertion-1 Parameter9 LSB			
46 03 14	2	00 - 7F	Insertion-1 Parameter10 MSB	#		
		00 - 7F	Insertion-1 Parameter10 LSB			

TOTAL SIZE = 22 16 (HEX)

Address	Size	Data Range(HEX)	Prameter Name	Description	Default(HEX)	Notes
46 04 00	2	00 - 7F	Insertion-2 Type MSB	Refer to Effect Parameter List	0000	
		00 - 7F	Insertion-2 Type LSB			
46 04 02	2	00 - 7F	Insertion-2 Parameter 1 MSB	#		Depends On Effect Type
		00 - 7F	Insertion-2 Parameter 1 LSB			
46 04 04	2	00 - 7F	Insertion-2 Parameter 2 MSB	#		
		00 - 7F	Insertion-2 Parameter 2 LSB			
46 04 06	2	00 - 7F	Insertion-2 Parameter 3 MSB	#		
		00 - 7F	Insertion-2 Parameter 3 LSB			
46 04 08	2	00 - 7F	Insertion-2 Parameter 4 MSB	#		
		00 - 7F	Insertion-2 Parameter 4 LSB			
46 04 0A	2	00 - 7F	Insertion-2 Parameter 5 MSB	#		
		00 - 7F	Insertion-2 Parameter 5 LSB			
46 04 0C	2	00 - 7F	Insertion-2 Parameter 6 MSB	#		
		00 - 7F	Insertion-2 Parameter 6 LSB			
46 04 0E	2	00 - 7F	Insertion-2 Parameter 7 MSB	#		
		00 - 7F	Insertion-2 Parameter 7 LSB			
46 04 10	2	00 - 7F	Insertion-2 Parameter 8 MSB	#		
		00 - 7F	Insertion-2 Parameter 8 LSB			
46 04 12	2	00 - 7F	Insertion-2 Parameter 9 MSB	#		
		00 - 7F	Insertion-2 Parameter 9 LSB			
46 04 14	2	00 - 7F	Insertion-2 Parameter 10 MSB	#		
		00 - 7F	Insertion-2 Parameter 10 LSB			
46 04 16	2	00 - 7F	Insertion-2 Parameter 11 MSB	#		
		00 - 7F	Insertion-2 Parameter 11 LSB			
46 04 18	2	00 - 7F	Insertion-2 Parameter 12 MSB	#		
		00 - 7F	Insertion-2 Parameter 12 LSB			
46 04 1A	2	00 - 7F	Insertion-2 Parameter 13 MSB	#		
		00 - 7F	Insertion-2 Parameter 13 LSB			
46 04 1C	2	00 - 7F	Insertion-2 Parameter 14 MSB	#		
		00 - 7F	Insertion-2 Parameter 14 LSB			
46 04 1E	2	00 - 7F	Insertion-2 Parameter 15 MSB	#		
		00 - 7F	Insertion-2 Parameter 15 LSB			
46 04 20	2	00 - 7F	Insertion-2 Parameter 16 MSB	#		
		00 - 7F	Insertion-2 Parameter 16 LSB			

TOTAL SIZE = 34 22 (HEX)

Address	Size	Data Range(HEX)	Prameter Name	Description	Default(HEX)	Notes
46 05 00	1	00 - 09	Controller Set1 Source	PB, MW, ---, AT, FC, FS, RB, BC, KN1, KN2	00	
46 05 01	2	00	Controller Set1 Destination MSB	0 - 29	00	
		00 - 1D	Controller Set1 Destination LSB			
46 05 03	1	00 - 7F	Controller Set1 Depth	-64 - +63	40	
46 05 04	1		reserved		00	
46 05 05	1	00 - 09	Controller Set2 Source	PB, MW, ---, AT, FC, FS, RB, BC, KN1, KN2	00	
46 05 06	2	00	Controller Set2 Destination MSB	0 - 29	00	
		00 - 1D	Controller Set2 Destination LSB			
46 05 08	1	00 - 7F	Controller Set2 Depth	-64 - +63	40	
46 05 09	1		reserved		00	
46 05 0A	1	00 - 09	Controller Set3 Source	PB, MW, ---, AT, FC, FS, RB, BC, KN1, KN2	00	
46 05 0B	2	00	Controller Set3 Destination MSB	0 - 29	00	
		00 - 1D	Controller Set3 Destination LSB			
46 05 0D	1	00 - 7F	Controller Set3 Depth	-64 - +63	40	
46 05 0E	1		reserved		00	
46 05 0F	1	00 - 09	Controller Set4 Source	PB, MW, ---, AT, FC, FS, RB, BC, KN1, KN2	00	
46 05 10	2	00	Controller Set4 Destination MSB	0 - 29	00	
		00 - 1D	Controller Set4 Destination LSB			
46 05 12	1	00 - 7F	Controller Set4 Depth	-64 - +63	40	
46 05 13	1		reserved		00	
46 05 14	1	00 - 09	Controller Set5 Source	PB, MW, ---, AT, FC, FS, RB, BC, KN1, KN2	00	
46 05 15	2	00	Controller Set5 Destination MSB	0 - 29	00	
		00 - 1D	Controller Set5 Destination LSB			
46 05 17	1	00 - 7F	Controller Set5 Depth	-64 - +63	40	
46 05 18	1		reserved		00	
46 05 19	1	00 - 09	Controller Set6 Source	PB, MW, ---, AT, FC, FS, RB, BC, KN1, KN2	00	
46 05 1A	2	00	Controller Set6 Destination MSB	0 - 29	00	
		00 - 1D	Controller Set6 Destination LSB			
46 05 1C	1	00 - 7F	Controller Set6 Depth	-64 - +63	40	
46 05 1D	1		reserved		00	

TOTAL SIZE = 30 1E (HEX)

MIDI PARAMETER CHANGE TABLE (DRUM VOICE KEY)

Address	Size	Data Range(HEX)	Prameter Name	Description	Default(HEX)	Notes
47 ee 00	1	00 - 01	Element Assign	off_on	00	*1
47 ee 01	1	00 - 03	Wave Type	wave_vce	00	
47 ee 02	1	00	reserved		00	
47 ee 03	1	00 - 01	Receive Note Off	off_on	01	
47 ee 04	1	00 - 01	Assign Mode	single_multi	01	*1
47 ee 05	1	00 - 7F	Alternate Group	0:off, 1 - 127	00	*1
47 ee 06	2	00 - 7F	Wave Number MSB	1st bit0 - 0 → bit13-7	00	
		00 - 7F	Wave Number LSB	2nd bit0 - 0 → bit6-0 (0:off), 1 - 553	00	
47 ee 08	3	00 - 7F	Voice Bank Number MSB	0 - 127	00	*1
		00 - 7F	Voice Bank Number LSB	0 - 127	00	*1
		00 - 7F	Voice Number	0 - 127	00	*1
47 ee 0B	1	01 - 7F	Pan	L63 - C - R63	40	*1
47 ee 0C	1	00 - 7F	Random Pan Depth	0 - 127	00	
47 ee 0D	1	00 - 7F	Alternate Pan Depth	L64 - 0 - R63	40	
47 ee 0E	1	00 - 7F	Reverb Send Level	0 - 127	28	*1
47 ee 0F	1	00 - 7F	Chorus Send Level	0 - 127	00	*1
47 ee 10	1	00 - 02	Insertion Effect Switch	thru.ins1.ins2	00	*1
47 ee 11	1		reserved		00	

TOTAL SIZE = 18 12 (HEX)

47 ee 20	1	00 - 7F	Element Level	0 - 127	64	*1
47 ee 21	1	00 - 7F	Level Velocity Sensitivity	-64 - +63	40	
47 ee 22	1	00	reserved		00	
47 ee 23	1	00 - 7F	AEG Attack Time	0 - 127	00	
47 ee 24	1	00 - 7F	AEG Decay1 Time	0 - 127	00	
47 ee 25	1	00 - 7F	AEG Decay2 Time	0 - 126,hold	7E	
47 ee 26	1	00	reserved		00	
47 ee 27	1	00	reserved		00	
47 ee 28	1	00	reserved		00	
47 ee 29	1	00 - 7F	AEG Decay1 Level	0 - 127	7F	
47 ee 2A	1	00	reserved		00	
47 ee 2B	1	00	reserved		00	

TOTAL SIZE = 12 0C (HEX)

48 ee 00	1	10 - 70	Coarse Tune	-48 - +48	40	*1
48 ee 01	1	00 - 7F	Fine Tune	-64 - +63	40	*1
48 ee 02	1	00 - 7F	Pitch Velocity Sensitivity	-64 - +63	40	

TOTAL SIZE = 3 03 (HEX)

49 ee 00	1	00	reserved		00	
49 ee 01	2	00 - 01	LPF Cutoff Frequency MSB	0 - 255	01 7F	
		00 - 7F	LPF Cutoff Frequency LSB			
49 ee 03	1	00 - 7F	LPF Cutoff Velocity Sensitivity	-64 - +63	40	
49 ee 04	1	00 - 1F	LPF Resonance	0 - 31	04	
49 ee 05	1	40	reserved		40	
49 ee 06	2	00 - 01	HPF Cutoff Frequency MSB	0 - 255	00 00	
		00 - 7F	HPF Cutoff Frequency LSB			

TOTAL SIZE = 8 08 (HEX)

4A ee 00	1	00 - 05	EQ Type	EQ LH, PEQ, Boost6, Boost12, Boost18, thru	00	
4A ee 01	1	00 - 1F	EQ Resonance	0 - 31	00	
4A ee 02	2	00 - 01	EQ 1 Frequency MSB	EQ L/H: 46-182, PEQ: 83-251	00 53	
		00 - 7F	EQ 1 Frequency LSB			
4A ee 04	1	20 - 60	EQ 1 GAIN	-32 - +32	40	
4A ee 05	2	00 - 01	EQ 2 Frequency MSB	EQ L/H:131-241	01 71	
		00 - 7F	EQ 2 Frequency LSB			
4A ee 07	1	20 - 60	EQ 2 GAIN	-32 - +32	40	

TOTAL SIZE = 8 08 (HEX)

ee = Element Number (00 - 48: C0 - C6)

*1: Only this parameter is available when Wave/Voice type is set to "vce" in the OSC wave screen.

<Table 10>
MIDI PARAMETER CHANGE TABLE (PLUGIN VOICE)

Address	Size	Data Range(HEX)	Parameter Name	Description	Default(HEX)	Notes
4C70 00	1	20 -7E	Voice Name1	32_126(ASCII)	-	
4C70 01	1	20 -7E	Voice Name2	32_126(ASCII)	-	
4C70 02	1	20 -7E	Voice Name3	32_126(ASCII)	-	
4C70 03	1	20 -7E	Voice Name4	32_126(ASCII)	-	
4C70 04	1	20 -7E	Voice Name5	32_126(ASCII)	-	
4C70 05	1	20 -7E	Voice Name6	32_126(ASCII)	-	
4C70 06	1	20 -7E	Voice Name7	32_126(ASCII)	-	
4C70 07	1	20 -7E	Voice Name8	32_126(ASCII)	-	
4C70 08	1	20 -7E	Voice Name9	32_126(ASCII)	-	
4C70 09	1	20 -7E	Voice Name10	32_126(ASCII)	-	
4C70 0A	1		reserved			
4C70 0B	1		reserved			
4C70 0C	1	00 -16	Voice Category	00_22(-, Sq)	00(-)	
4C70 0D	1		reserved			
4C70 0E	1		reserved			
4C70 0F	1		reserved			
4C70 10	1		reserved			
4C70 11	1		reserved			
4C70 12	1		reserved			
4C70 13	1	00 -7F	ARP Type	UpOct1 - GateCur3	00	
4C70 14	1	00 -01	ARP Switch	off.on	00	
4C70 15	1	00 -02	ARP Hold	sync-off.off.on	01	
4C70 16	1	00 -06	ARP Unit Multipliy	50%,66%,75%,100%,133%,150%,200%	03	
4C70 17	1	00 -7F	ARP Note Limit Low	C-2_G8	00	
4C70 18	1	00 -7F	ARP Note Limit High	C-2_G8	7F	
4C70 19	1	00 -02	ARP Key Mode	sort.thru.direct	00	
4C70 1A	1	00 -01	ARP Unit Mode	original.thru	00	
4C70 1B	2	0000 -00C8	ARP Velocity Rate MSB	ARP Velocity Rate LSB	0_200%	
4C70 1D	2	0000 -00C8	ARP Gate Time Rate MSB	ARP Gate Time Rate LSB	0_200%	
4C70 1F	2	0019 -012C	ARP Tempo MSB	ARP Tempo LSB	25_300	
4C70 21	1	01 -7F	OED Pan	L63_C_R63	40	
4C70 22	1		reserved			
4C70 23	1	00 -7F	OED Chorus Control		40	
4C70 24	1	00 -7F	OED Release Time		40	
4C70 25	1		reserved			
4C70 26	1		reserved			
4C70 27	1		reserved			
4C70 28	1	00 -7F	OED KnobA		40	
4C70 29	1	00 -7F	OED KnobB		40	
4C70 2A	1	00 -7F	OED KnobC		40	
4C70 2B	1	00 -7F	OED/Scene 1 Knob1		40	
4C70 2C	1	00 -7F	OED/Scene 1 Knob2		40	
4C70 2D	1	00 -7F	OED/Scene 1 Cutoff Frequency		40	
4C70 2E	1	00 -7F	OED/Scene 1 Resonance		40	
4C70 2F	1	00 -7F	OED/Scene 1 Attack Time		40	
4C70 30	1	00 -7F	OED/Scene 1 Decay Time		40	
4C70 31	1	00 -7F	Scene 2 Knob1		40	
4C70 32	1	00 -7F	Scene 2 Knob2		40	
4C70 33	1	00 -7F	Scene 2 Cutoff Frequency		40	
4C70 34	1	00 -7F	Scene 2 Resonance		40	
4C70 35	1	00 -7F	Scene 2 Attack Time		40	
4C70 36	1	00 -7F	Scene 2 Decay Time		40	
4C70 37	1	00 -7F	Scene Control		00	
TOTAL SIZE = 56 38 (HEX)						
4C00 00	1	00 -7F	Volume	0 - 127	64	
4C00 01	1		reserved			
4C00 02	1	00 -01	Same Note Number Key On Assig.	single_multi	01	
4C00 03	1	00 -01	Mono/Poly Mode	mono.poly	01	
4C00 04	1		reserved			
4C00 05	1	28 -58	Pitch Bend Range	-24,+24[semitones]	42	
4C00 06	1		reserved		3E	
4C00 07	1		reserved			
4C00 08	1	00 -01	Portamento Switch	off.on	00	
4C00 09	1	00 -7F	Portamento Time	0 - 127	00	
4C00 0A	1		reserved			
4C00 0B	1	00 -7F	Reverb Send	--dB_0dB	00	
4C00 0C	1	00 -7F	Chorus Send	--dB_0dB	00	
TOTAL SIZE = 13 0D (HEX)						
4C01 00	2	00 -7F	Reverb Type MSB	Refer to Effect Parameter List	0100	
4C01 01	2	00 -7F	Reverb Type LSB			
4C01 02	2	00 -7F	Reverb Parameter 1 MSB	"	init value for hall1	
4C01 03	2	00 -7F	Reverb Parameter 1 LSB	"		
4C01 04	2	00 -7F	Reverb Parameter 2 MSB	"	init value for hall1	
4C01 05	2	00 -7F	Reverb Parameter 2 LSB	"		
4C01 06	2	00 -7F	Reverb Parameter 3 MSB	"	init value for hall1	
4C01 07	2	00 -7F	Reverb Parameter 3 LSB	"		
4C01 08	2	00 -7F	Reverb Parameter 4 MSB	"	init value for hall1	
4C01 09	2	00 -7F	Reverb Parameter 4 LSB	"		
4C01 0A	2	00 -7F	Reverb Parameter 5 MSB	"	init value for hall1	
4C01 0B	2	00 -7F	Reverb Parameter 5 LSB	"		
4C01 0C	2	00 -7F	Reverb Parameter 6 MSB	"	init value for hall1	
4C01 0D	2	00 -7F	Reverb Parameter 6 LSB	"		
4C01 0E	2	00 -7F	Reverb Parameter 7 MSB	"	init value for hall1	
4C01 0F	2	00 -7F	Reverb Parameter 7 LSB	"		
4C01 10	2	00 -7F	Reverb Parameter 8 MSB	"	init value for hall1	
4C01 11	2	00 -7F	Reverb Parameter 8 LSB	"		
4C01 12	2	00 -7F	Reverb Parameter 9 MSB	"	init value for hall1	
4C01 13	2	00 -7F	Reverb Parameter 9 LSB	"		
4C01 14	2	00 -7F	Reverb Parameter 10 MSB	"	init value for hall1	
4C01 15	2	00 -7F	Reverb Parameter 10 LSB	"		
4C01 16	1	00 -7F	Reverb Return	--dB_0dB_+6dB(0_96...127)	40	
4C01 17	1	01 -7F	Reverb Pan	L63_C_R63	40	
TOTAL SIZE = 24 18 (HEX)						
4C02 00	2	00 -7F	Chorus Type MSB	Refer to Effect Parameter List	0500	
4C02 01	2	00 -7F	Chorus Type LSB			
4C02 02	2	00 -7F	Chorus Parameter 1 MSB	"	init value for chorus1	
4C02 03	2	00 -7F	Chorus Parameter 1 LSB	"		
4C02 04	2	00 -7F	Chorus Parameter 2 MSB	"	init value for chorus1	
4C02 05	2	00 -7F	Chorus Parameter 2 LSB	"		
4C02 06	2	00 -7F	Chorus Parameter 3 MSB	"	init value for chorus1	
4C02 07	2	00 -7F	Chorus Parameter 3 LSB	"		
4C02 08	2	00 -7F	Chorus Parameter 4 MSB	"	init value for chorus1	
4C02 09	2	00 -7F	Chorus Parameter 4 LSB	"		
4C02 0A	2	00 -7F	Chorus Parameter 5 MSB	"	init value for chorus1	
4C02 0B	2	00 -7F	Chorus Parameter 5 LSB	"		
4C02 0C	2	00 -7F	Chorus Parameter 6 MSB	"	init value for chorus1	
4C02 0D	2	00 -7F	Chorus Parameter 6 LSB	"		
4C02 0E	2	00 -7F	Chorus Parameter 7 MSB	"	init value for chorus1	
4C02 0F	2	00 -7F	Chorus Parameter 7 LSB	"		
4C02 10	2	00 -7F	Chorus Parameter 8 MSB	"	init value for chorus1	
4C02 11	2	00 -7F	Chorus Parameter 8 LSB	"		
4C02 12	2	00 -7F	Chorus Parameter 9 MSB	"	init value for chorus1	
4C02 13	2	00 -7F	Chorus Parameter 9 LSB	"		
4C02 14	2	00 -7F	Chorus Parameter 10 MSB	"	init value for chorus1	
4C02 15	2	00 -7F	Chorus Parameter 10 LSB	"		
4C02 16	1	00 -7F	Chorus Return	--dB_0dB_+6dB(0_96...127)	40	
4C02 17	1	01 -7F	Chorus Pan	L63_C_R63	40	
4C02 18	1	00 -7F	Send Chorus To Reverb	--dB_0dB(0_127)	00	
TOTAL SIZE = 25 19 (HEX)						

Address	Size	Data Range(HEX)	Parameter Name	Description	Default(HEX)	Notes
4C03 00	2	00 -7F	Insertion Type MSB	Refer to Effect Parameter List	0000	
4C03 01	2	00 -7F	Insertion Type LSB			
4C03 02	2	00 -7F	Insertion Parameter1 MSB	"	0000	
4C03 03	2	00 -7F	Insertion Parameter1 LSB			
4C03 04	2	00 -7F	Insertion Parameter2 MSB	"	0000	
4C03 05	2	00 -7F	Insertion Parameter2 LSB			
4C03 06	2	00 -7F	Insertion Parameter3 MSB	"	0000	
4C03 07	2	00 -7F	Insertion Parameter3 LSB			
4C03 08	2	00 -7F	Insertion Parameter4 MSB	"	0000	
4C03 09	2	00 -7F	Insertion Parameter4 LSB			
4C03 0A	2	00 -7F	Insertion Parameter5 MSB	"	0000	
4C03 0B	2	00 -7F	Insertion Parameter5 LSB			
4C03 0C	2	00 -7F	Insertion Parameter6 MSB	"	0000	
4C03 0D	2	00 -7F	Insertion Parameter6 LSB			
4C03 0E	2	00 -7F	Insertion Parameter7 MSB	"	0000	
4C03 0F	2	00 -7F	Insertion Parameter7 LSB			
4C03 10	2	00 -7F	Insertion Parameter8 MSB	"	0000	
4C03 11	2	00 -7F	Insertion Parameter8 LSB			
4C03 12	2	00 -7F	Insertion Parameter9 MSB	"	0000	
4C03 13	2	00 -7F	Insertion Parameter9 LSB			
4C03 14	2	00 -7F	Insertion Parameter10 MSB	"	0040	
4C03 15	2	00 -7F	Insertion Parameter10 LSB			
TOTAL SIZE = 22 16 (HEX)						

4C05 00	1	00 -09	Controller Set1 Source	PB, MW, ---, AT, FC, FS, RB, BC, KN1, KN2	00	
4C05 01	2	00	Controller Set1 Destination MSB	0 - 13	00	
4C05 02	2	00 -0D	Controller Set1 Destination LSB		00	
4C05 03	1	00 -7F	Controller Set1 Depth	-64 +63	40	
4C05 04	1		reserved			
4C05 05	1	00 -09	Controller Set2 Source	PB, MW, ---, AT, FC, FS, RB, BC, KN1, KN2	00	
4C05 06	2	00	Controller Set2 Destination MSB	0 - 13	00	
4C05 07	2	00 -0D	Controller Set2 Destination LSB		00	
4C05 08	1	00 -7F	Controller Set2 Depth	-64 +63	40	
4C05 09	1		reserved		00	
TOTAL SIZE = 10 0A (HEX)						

4C10 00	1	00 -7F	Voice Bank MSB	0_127		depends on plug-in board
4C10 01	1	00 -7F	Voice Bank LSB	0_127		depends on plug-in board
4C10 02	1	00 -7F	Voice Number	0_127		depends on plug-in board
4C10 03	1	28 -58	Note Shift	24_0,+24[semitones]		
4C10 04	1	00 -7F	Velocity Sense Depth	0_127		
4C10 05	1	00 -7F	Velocity Sense Offset	0_127		
4C10 06	1	00 -7F	(Vibrato Rate) LFO Speed	-64 +63		
4C10 07	1	00 -7F	(Vibrato Depth) LFO Pitch Depth	-64 +63		
4C10 08	1	00 -7F	(Vibrato Delay) LFO Delay	-64 +63		
4C10 09	1	00 -7F	MW Filter Control	-64 +63		
4C10 0A	1		reserved	0		
4C10 0B	1	00 -7F	MW LFO Pitch Modulation Depth	0_127		0A
4C10 0C	1	00 -7F	MW LFO Filter Modulation Depth	0_127		00
4C10 0D	1	00 -7F	MW LFO Amplitude Modulation Depth	0_127		00
4C10 0E	1	28 -58	CAT Pitch Control	-24,+24[semitones]		
4C10 0F	1	00 -7F	CAT Filter Control	-64 +63		
4C10 10	1		reserved	-64 +63		
4C10 11	1	00 -7F	CAT LFO Pitch Modulation Depth	0_127		00
4C10 12	1	00 -7F	CAT LFO Filter Modulation Depth	0_127		00
4C10 13	1	00 -7F	CAT LFO Amplitude Modulation Depth	0_127		00
4C10 14	1	00 -5F	AC1 Controller Number	0_95		10
4C10 15	1	00 -7F	AC1 Filter Control	-64 +63		40
4C10 16	1		reserved	-64 +63		40
4C10 17	1	00 -7F	AC1 LFO Pitch Modulation Depth	0_127		00
4C10 18	1	00 -7F	AC1 LFO Filter Modulation Depth	0_127		00
4C10 19	1	00 -7F	AC1 LFO Amplitude Modulation Depth	0_127		00
4C10 1A	1	00 -7F	Pitch EG Initial Level	-64 +63		40
4C10 1B	1	00 -7F	Pitch EG Attack Time	-64 +63		40
4C10 1C	1	00 -7F	Pitch EG Release Level	-64 +63		40
4C10 1D	1	00 -7F	Pitch EG Release Time	-64 +63		40
4C10 1E	1	00 -7F	EQ Low Gain	-64 +63(-12 +12dB)		40
4C10 1F	1	00 -7F	EQ High Gain	-64 +63(-12 +12dB)		40
4C10 20	1	04 -28	EQ Low Frequency	32_2.0k(Hz)		0C
4C10 21	1	1C -3A	EQ High Frequency	500_16.0k(Hz)		36
4C10 22	1	00 -7F	HPF Cutoff Frequency	-64_0,+63		40
TOTAL SIZE = 35 23 (HEX)						

4C20 00	64	00 -7F	Plug-in Board Native Parameter	depends on Plug-in Board	00	
4C20 40	3	00 -7F	Plug-in Board Type MSB			depends on plug-in board
4C20 41	3	00 -7F	Plug-in Board Type LSB			depends on plug-in board
4C20 42	3	00 -7F	Plug-in Board Version Number			depends on plug-in board
4C20 43	1	00 -7F	reserved		00	
TOTAL SIZE = 68 44 (HEX)						

Function...	Transmitted	Recognized	Remarks
Basic Channel Default Changed	1 - 16 1 - 16	1 - 16 1 - 16	Memorised
Mode Default Messages Altered	3 X *****	1 1 - 4(m=1) *2 X	Memorised
Note Number : True voice	0 - 127 *****	0 - 127 0 - 127	Transpose
Velocity Note ON Note OFF	O 9nH,v=1-127 X 9nH,v=0	O v=1-127 X	
After Touch Key's Ch's	X O	X O	*1
Pitch Bend	O	O	*1
Control Change 0,32 1,7,11 5,10 6,38 64 65 66 71-75 91,93 96-97 100-101 1-95	O X X X X X X X X X X O	O O O O O O O O O O O O	*1 *1 *1 *1 *1 *1 *1 *1 *1 *1 *1 *1 *1 Bank Select Data Entry Sustain Sw Portamento Sw Sosutenuto Sound Controller Effect Depth RPN Inc,Dec RPN LSB,MSB Assignable Cntrl
Prog Change : True #	O 0 - 127 *****	O 0 - 127 0 - 127	
System Exclusive	O	O	
Common : Song Pos. : Song Sel. : Tune	X X X	X X X	
System : Clock Real Time : Commands	X X	O X	
Aux : All Sound Off : Reset All Cntrls : Local ON/OFF Mes- : All Notes OFF sages: Active Sense : Reset	X X X X O X	O (120,126,127) O (121) X O (123-125) O X	
Notes: *1 receive if switch is on. *2 m is always treated as "1" regardless of its value.			

Function...	Transmitted	Recognized	Remarks
Basic Channel Default Changed	1 - 16 X	X X	Memorised
Mode Default Messages Altered	X X *****	X X X	
Note Number : True voice	0 - 127 *****	X X	
Velocity Note ON Note OFF	O 9nH,v=1-127 X 9nH,v=0	X X	
After Touch Key's Ch's	O O	X X	
Pitch Bend	O	X	
Control Change 0-121	O	X	
Prog Change : True #	O 0 - 127 *****	X	
System Exclusive	O	X	
Common : Song Pos. : Song Sel. : Tune	X X X	X X X	
System : Clock Real Time : Commands	O *2 O *2	O *1 *2 O *2	
Aux : All Sound Off : Reset All Cntrls : Local ON/OFF Mes- : All Notes OFF sages: Active Sense : Reset	O O O O O X	X X X X X X	
Notes: *1 if MIDI Sync is midi *2 if MIDI Control in is on			

Mode 1 : OMNI ON , POLY
 Mode 3 : OMNI OFF, POLY

Mode 2 : OMNI ON ,MONO
 Mode 4 : OMNI OFF,MONO

O : Yes
 X : No

