

YAMAHA

MULTI TRACK

CASSETTE RECORDER



MT44

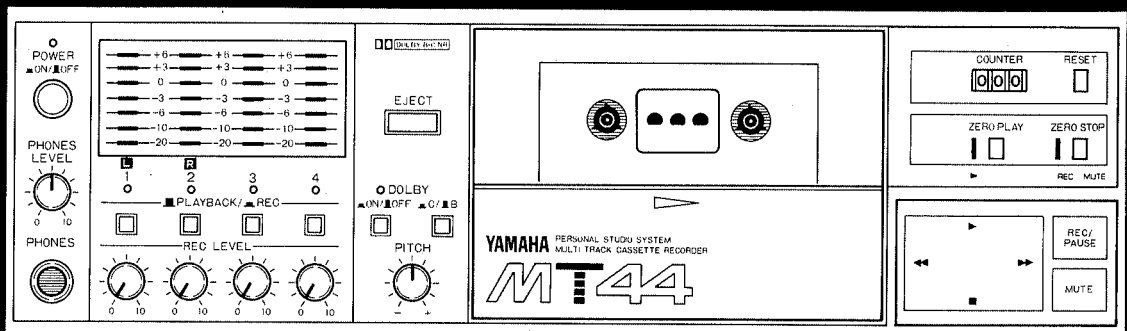

OPERATING MANUAL



Thank you for purchasing a Yamaha MT44 Multitrack Cassette Recorder. The MT44 is a tremendous creative tool for musicians, composers, arrangers, recording enthusiasts, or people involved with audio-visual production. It offers 4-channel multitrack recording capability on standard compact cassettes, making it easy to produce professional-sounding multitrack master tapes.

Built in Dolby B and Dolby C noise reduction systems mean clean, high-quality recordings, while a logic-controlled transport with ZERO STOP and ZERO PLAY auto locator functions lets you concentrate on creating, not on controlling the deck. We urge you to read this manual thoroughly in order to get the best possible performance from your MT44.

	CAUTION RISK OF ELECTRIC SHOCK DO NOT OPEN	
CAUTION: TO REDUCE THE RISK OF ELECTRIC SHOCK, DO NOT REMOVE COVER (OR BACK). NO USER-SERVICEABLE PARTS INSIDE REFER SERVICING TO QUALIFIED SERVICE PERSONNEL.		

Explanation of Graphical Symbols	
	The lightning flash with arrowhead symbol, within an equilateral triangle, is intended to alert you to the presence of uninsulated "dangerous voltage" within the product's enclosure that may be of sufficient magnitude to constitute a risk of electric shock to persons.
	The exclamation point within an equilateral triangle is intended to alert you to the presence of important operating and maintenance (servicing) instructions in the literature accompanying the appliance.

CONTENTS

PRE-USE CAUTIONS 2

NAMES OF THE PARTS AND THEIR FUNCTIONS 3

MULTITRACK TECHNIQUES 5

SENSOR SEALS/CASSETTE TAPES 7

CONNECTION DIAGRAM 8

BLOCK DIAGRAM/SPECIFICATIONS 9

MAINTENANCE 10

PRE-USE CAUTIONS

- The MT44 functions as a standard stereo cassette deck when loaded with any standard stereo cassette tape. For four-channel multitrack recording a special sensor foil (supplied) must be affixed to the cassette housing window.
- The MT44 is designed exclusively for use with high-quality chrome-formulation cassette tape (High Bias, 70 μ sec. EQ). Avoid CI20 tape lengths because the extreme thinness of the tape can result in degraded sound quality and damage to the transport system.
- To ensure a high signal-to-noise ratio and minimum distortion, the MT44 has a high-quality permalloy reproduction head. Oxide flakes from old tape and dust or dirt can impair the performance of this head, so it should be cleaned regularly with cotton buds and a tape head cleaning fluid, or a head cleaning tape. The pinch roller should also be cleaned at the same time.
- Locate the MT44 out of the direct rays of the sun, avoiding locations subject to vibration and excessive dust, heat, cold or moisture.
- Irreparable damage may result from opening the MT44 cabinet or attempting to alter the internal circuitry.
- Avoid dropping your MT44 or subjecting it to any type of shock, as impaired performance may result.
- Do not attempt to clean any accumulations of dirt with chemical solvents (such as alcohol or benzene).
Wipe only with a clean completely dry cloth.
- Voltage selector switch on the rear of the MT44 must be set for your local mains voltage BEFORE plugging in the AC main supply.
Voltage are 110-130 or 220-240 AC, 50/60Hz.
U.S. and Canadian models are not provided with the voltage selector.

CAUTION (PREPARED IN ACCORDANCE WITH UL STANDARD 1270)

1. Read Instructions — All the safety and operating instructions should be read before the appliance is operated.
2. Retain Instructions — The safety and operating instructions should be retained for future reference.
3. Heed Warnings — All warnings on the appliance and in the operating instructions should be adhered to.
4. Follow Instructions — All operating and use instructions should be followed.
5. Water and Moisture — The appliance should not be used near, water — for example, near a bathtub, washbowl, kitchen sink, laundry tub, in a wet basement, or near a swimming pool, etc.
6. Carts and Stands — The appliance should be used only with a cart or stand that is recommended by the manufacturer.
7. Wall or Ceiling Mounting — The appliance should be mounted to a wall or ceiling only as recommended by the manufacturer.
8. Ventilation — The appliance should be situated so that its location or position does not interfere with its proper ventilation. For example, the appliance should not be situated on a bed, sofa, rug, or similar surface that may block the ventilation openings; or, placed in a built-in installation, such as a bookcase or cabinet that may impede the flow of air through the ventilation openings.
9. Heat — The appliance should be situated away from heat sources such as radiators, heat registers, stoves, or other appliances (including amplifiers) that produce heat.
10. Power Sources — The appliance should be connected to a power supply only of the type described in the operating instructions or as marked on the appliance.
11. Power-Cord Protection — Power-supply cords should be routed so that they are not likely to be walked on or pinched by items placed upon or against them, paying particular attention to cords at plugs, convenience receptacles, and the point where they exit from the appliance.
12. Cleaning — The appliance should be cleaned only as recommended by the manufacturer.
13. Nonuse Periods — The power cord of the appliance should be unplugged from the outlet when left unused for a long period of time.
14. Object and Liquid Entry — Care should be taken so that objects do not fall and liquids are not spilled into the enclosure through openings.
15. Damage Requiring Service — The appliance should be serviced by qualified service personnel when:
 - A. The power-supply cord or the plug has been damaged; or
 - B. Objects have fallen, or liquid has been spilled into the appliance; or
 - C. The appliance has been exposed to rain; or
 - D. The appliance does not appear to operate normally or exhibits a marked change in performance; or
 - E. The appliance has been dropped, or the enclosure damaged.
16. Servicing — The user should not attempt to service the appliance beyond that described in the operating instructions. All other servicing should be referred to qualified service personnel.

NAMES OF THE PARTS AND THEIR FUNCTIONS

FRONT PANEL

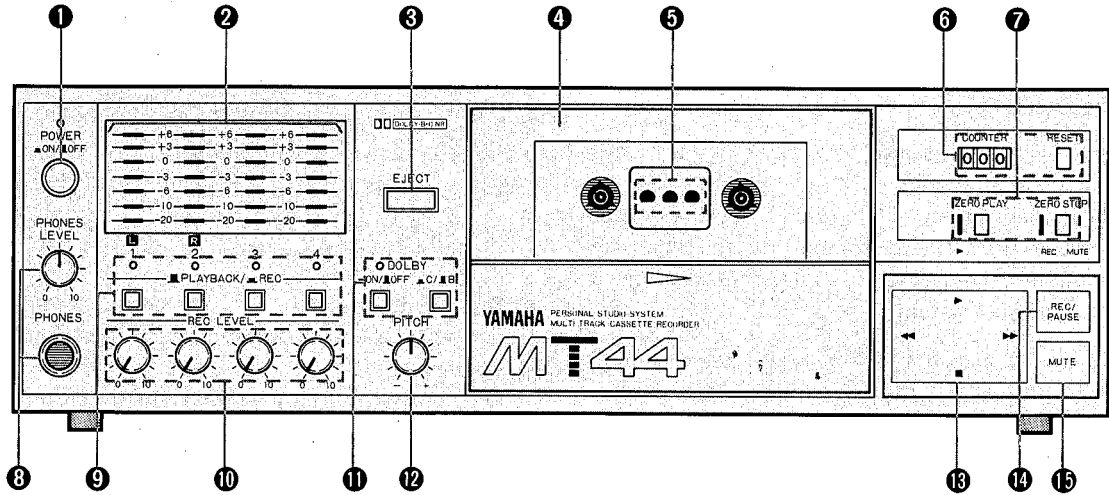

REAR PANEL

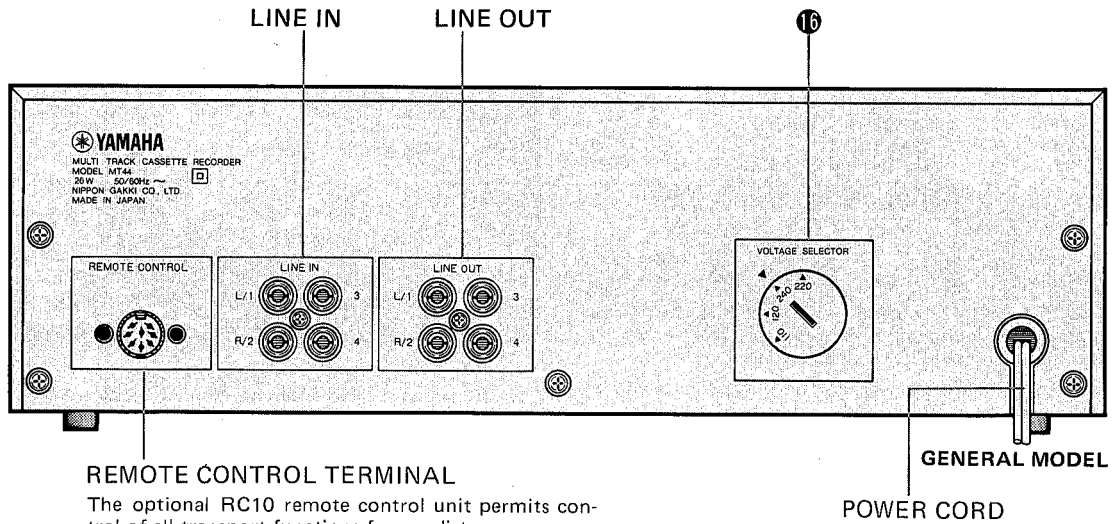

REMOTE CONTROL TERMINAL

The optional RC10 remote control unit permits control of all transport functions from a distance.

POWER CORD

1 POWER SWITCH/INDICATOR

Pressing this switch turns power ON and causes the power indicator to light. Pressing the POWER switch a second time turns the unit OFF.

2 LEVEL INDICATORS

These fast-response LED level indicators display the record and playback levels of each of the MT44's four channels. For the best recording quality record levels should be set to the highest level possible before distortion sets in-between 0 and +3dB. In the 2-channel mode the leftmost 2 meters indicate left and right channel levels.

3 EJECT BUTTON

When this button is pressed, the cassette holder opens.

Use when loading and unloading cassette tapes.

4 CASSETTE COMPARTMENT

To load a cassette tape, press the Eject button and the cassette compartment cover will open. Keep cover closed when the deck is not in use to protect heads and mechanism from dust, etc.

5 4-CHANNEL SENSOR

When one of the supplied sensor seals is affixed to the cassette window, the MT44 is automatically set to the 4-track mode when the tape is loaded.

6 TAPE COUNTER/RESET BUTTON

Before starting recording, press this button to set the tape counter to "000". Noting the counter number at the beginning of each selection will be useful for later reference.

7 ZERO PLAY/ZERO STOP

Zero play:

When the ZERO PLAY button is engaged and the rewind button is pressed, the tape rewinds to the counter "000" point, stops, and automatically begins playback.

Zero stop:

When the ZERO STOP button is engaged and the rewind button is pressed, the tape rewinds to the counter "000" point and stops automatically.

8 PHONES JACK AND LEVEL CONTROL

Any standard pair of stereo headphones can be connected here for monitoring purposes. When the deck is in the 4-track mode tracks 1 and 3 are sent to the left channel and tracks 2 and 4 are sent to the right channel of the stereo headphone signal. The PHONES LEVEL control adjusts headphone volume for the most comfortable monitoring level.

9 PLAYBACK/RECORD BUTTONS

These buttons select the playback and record channels for recording, overdubbing, ping-pong or punch-in/punch-out record operations when the deck is in the 4-track mode. The indicator associated with each channel's selector glows green for playback and red for record.

* These buttons function only in the 4-track record mode.

10 RECORD LEVEL CONTROLS

Each control adjusts the record level of the corresponding channel. Best results are achieved with the levels set between 0 and +3dB.

11 DOLBY NR

Dolby noise reduction is an extremely effective method of reducing background hiss on tapes. The MT44 incorporates both Dolby B NR and the newer Dolby C NR system. Dolby C NR is approximately twice as effective as Dolby B NR, providing new levels of noise-free performance.

Switch the Dolby NR system on with the button on the left, then select Dolby B or C NR with the button on the right.

Tapes recorded with Dolby B NR should be played back with Dolby B NR on, and tapes recorded with Dolby C NR should be played back with Dolby C NR on. Tapes not Dolby NR-encoded should be played back with Dolby NR off.

* Dolby and the double D mark are trademarks of Dolby Laboratories licensing Corp. Dolby noise reduction system manufactured under license from Dolby Laboratories Licensing Corp.

12 PITCH CONTROL

This control permits adjustment of tape speed over a $\pm 10\%$ range. The pitch control makes it possible to match the pitch of recorded tracks with that of a live instrument to be recorded.

* The pitch control will function for 2-channel playback and 4-track record/playback, but not for 2-channel recording.

13 TAPE TRAVEL OPERATION CONTROL PANEL (REWIND/PLAY/FAST FORWARD/STOP)

REWIND: Press the "◀" section of the control panel to rewind the tape.

PLAY: Press the "▶" section of the control panel for playback. Pressing this switch causes "▶" indicator to light.

It is also necessary to use this control to engage the record mode. To engage recording, it is necessary to engage the Play mode while in Rec. standby.

FAST FORWARD: Press the "▶▶" section of the control panel to fast forward the tape.

STOP: Press the "■" section of the control panel to stop the tape while in any mode.

* The deck will stop automatically when the tape reaches the end of a side during playback, record, fast forward or rewind.

* Pressing the control panel in between the indicated sections instead of directly on them may give you a mode other than the one you want.

14 REC/PAUSE BUTTON

This button sets the deck to the record standby mode. In this mode the REC indicators light. Adjust record levels in this mode, then press (Play) to begin actual recording. The REC/PAUSE button can be pressed at any time during recording to return to the record standby mode.

* The PLAYBACK/REC buttons of the channels to be recorded must be set to REC to record in the 4-track mode.

Set the appropriate PLAYBACK/REC buttons to REC to set record levels.

15 MUTE BUTTON

Press this button during recording to leave a blank segment on the tape corresponding to the period for which the button is pressed.

The MUTE button is ideal for inserting spaces between recordings.

16 VOLTAGE SELECTOR (General Model Only)

Set this to your local AC mains voltage. Failure to do so will result in seriously impaired performance or even severe damage.

MULTITRACK TECHNIQUES

• BASIC RECORDING

Don't worry about the balance between channels when initially recording the tracks. Instead, pay attention to setting record levels for the best quality—minimum distortion and maximum signal-to-noise ratio. Optimum record level is normally when the program peaks read between 0 and +3dB on the LED level indicators. You can set up the ideal overall balance when mixing your 4-track master tape down to stereo on a standard stereo deck.

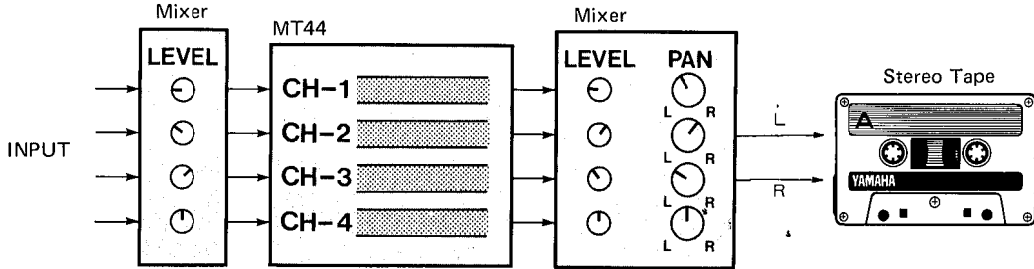

• OVERDUBBING

With the MT44 it is possible to build up an entire musical arrangement, part by part, playing each instrument by yourself.

This is possible because the MT44 lets you monitor already-recorded tracks while recording new tracks—in perfect synchronization.

Example:

Record the drums on channel 1, guitar on channel 2, and synthesizer on channel 3.

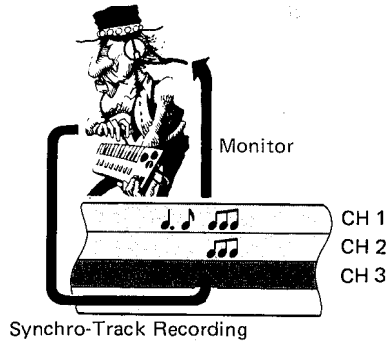

• PING-PONG RECORDING

If you want to record more than 4 parts, one at a time, you'll need to know about "ping-pong" recording. With this technique you record on tracks 1, 2 and 3, and then record these three tracks onto track 4 so tracks 1, 2 and 3 are opened up for further recording. With some resourceful ping-pong, you should be able to record up to 10 independent tracks as shown in the accompanying example.

An MM30 mixer and RB30 patch bay can make ping-ponging and other advanced multitrack techniques easy.

Example:

Recording tracks "A" through "J" using the ping-pong process.

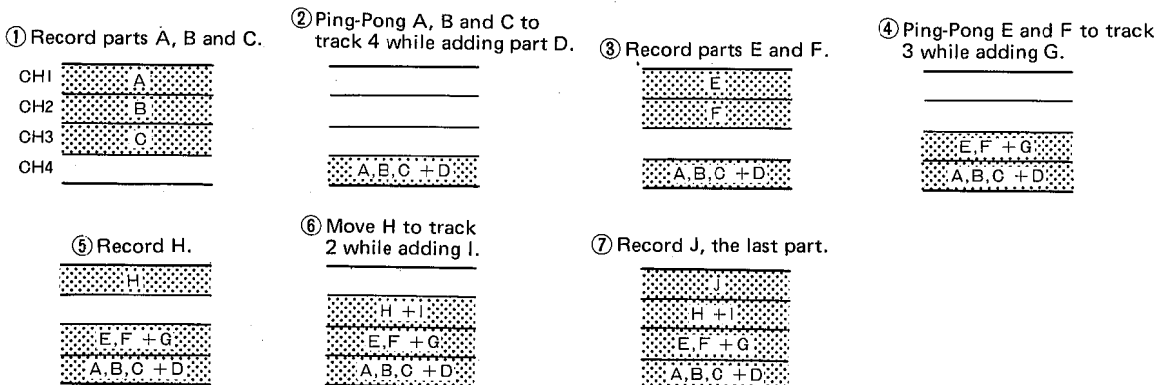

● PUNCH-IN/PUNCH-OUT RECORDING

This handy technique makes it possible to re-do a section of a track without having to re-record the entire track. Start playback from a point on the track somewhat before the section to be redone, then, at an appropriate "break" in the sound, engage the REC mode for that track and start playing. This is the PUNCH-IN operation. Disengage REC at the end of the required section—PUNCH-OUT—and the job is done.

This technique requires precision timing on the part of the player and recording engineer—often the same person—but the ability to correct mistakes like this can save lots of time and effort.

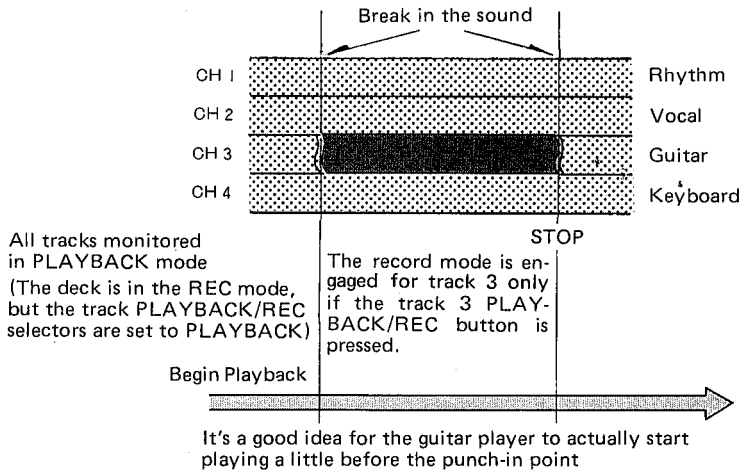

The techniques presented in this manual are by no means the only way to record with the MT44, so use your imagination and develop your own techniques. With a little resourcefulness and creativity the MT44 will enable you to create high-quality multitrack master tapes to test out musical ideas, show off your talents or simply hone your recording skills.

Glossary

LED

Light-emitting diode, a solid state device which emits light when current is passed through it.

LEVEL

The amplitude of a sound or signal, expressed in dB.

LEVEL INDICATOR

A device for displaying the dB amplitude of locale of a signal. VU meters are examples of level meters, but modern equipment is tending to use LED level indicators because of their greater reliability, ease of use and greater accuracy.

CLIPPING

When an electronic circuit is driven beyond the maximum voltage it can deliver it is said to be clipping. This word comes from the appearance of the output waveform when clipping occurs; it looks as though the top and bottom have been clipped off.

DISTORTION

A change in the waveshape and spectrum of a signal, usually referring to a nonlinear process which adds extra frequency components which were not present in the original signal.

dBm

This is a dB measurement which uses 1 milliwatt in 600 ohms as the reference. This is equal to 0.775 volts in a 600 ohm line but is meaningless if the impedance is changed.

dBv

This is a dB measurement which uses 0.775 volts as its reference level. It is independent of the impedance of the circuit under consideration. In a 600 ohm system it is equivalent to dBm.

dBV

This is a dB measurement which uses 1 volt as its reference. It is independent of the impedance of the system under consideration.

MICROPHONE LEVEL

The average signal level out of a microphone. Microphones vary widely in their output level, both between microphone types and with the particular sound being picked up. Microphone levels are normally assumed to be around 0.001 volt or 57dBv. Signal levels 50dB higher than this are not uncommon when miking such instruments as drums.

SENSOR SEALS / CASSETTE TAPES

〈SENSOR SEALS〉

■ Using the Supplied Sensor Seals

The MT44 automatically switches to the 2-channel mode (regular stereo cassette) or 4-track mode according to whether a sensor seal is detected on the loaded cassette. Note that only one side of the tape can be used in the 4-track mode.

For regular 2-channel operation load a cassette without the sensor seal.

For 4-track operation affix one of the three types of seals provided to the cassette window. Match the size of the seal to the cassette window. The seal must fit the cassette window properly or the MT44 may "misread" the seal and switch to the wrong mode. If one of the provided seal sizes does not fit, use a seal that is larger than the cassette window and trim it to size.

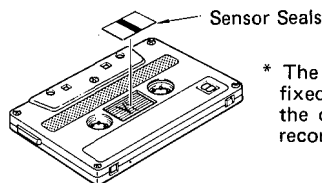

* The seal should be affixed to the "B" side of the cassette for 4-track recording on side "A".

〈CASSETTE TAPES〉

■ Protecting Your Recordings

All cassettes have record protection tabs along the top edge of the cassette shell. If this tab is broken out using a screwdriver or any other appropriate implement, recording will be inhibited on the corresponding side of the tape, thereby protecting your recordings from accidental erasure.

To record on a tape that has already had its tab removed, simply fix a piece of adhesive tape over the hole left by the tab.

Break out both the side "A" and "B" tabs to protect 4-track tapes.

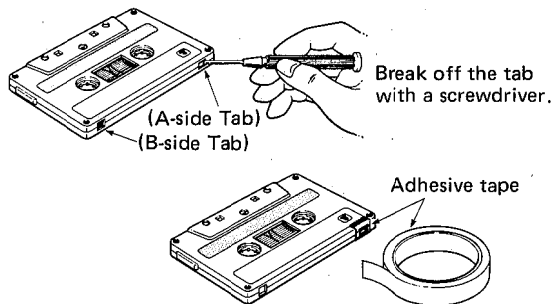

● Warning

Material recorded on this deck cannot, according to copyright laws, be used for any purpose other than personal enjoyment without the permission of the author of the material.

● Correcting slack tape

If the tape is used when it is slack or has jumped out of the cassette, there is a risk it may become tangled around the capstan or pinch roller. In order to correct this, insert a pencil or ball point pen into the center of a reel, rotate and take up loose slack in the tape.

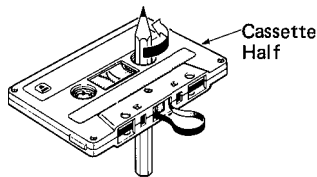

● Storage of cassette tapes

To prevent slackening of tape, fit a stopper or keep cassettes in a case (available commercially). Do not store in locations with direct sunlight, humidity, high temperature or magnetic fields (e.g., in the vicinity of televisions or speakers). High temperature and humidity will spoil tapes, while magnetic fields will erase recordings.

NOTE:

The MT44 has been specifically designed to provide optimum sound quality with chrome (CrO₂) formulation tape (High Bias, 70 μ sec. EQ). Do not use ferrichrome type tapes.

CONNECTION DIAGRAM

Example:

Monitor speaker MS10
(Powered speaker)

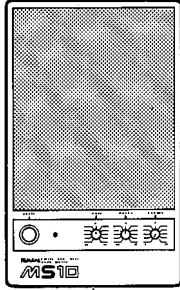

Monitor speaker MS10
(Powered speaker)

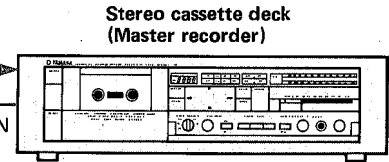
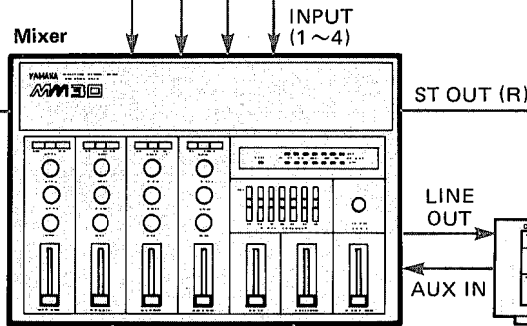
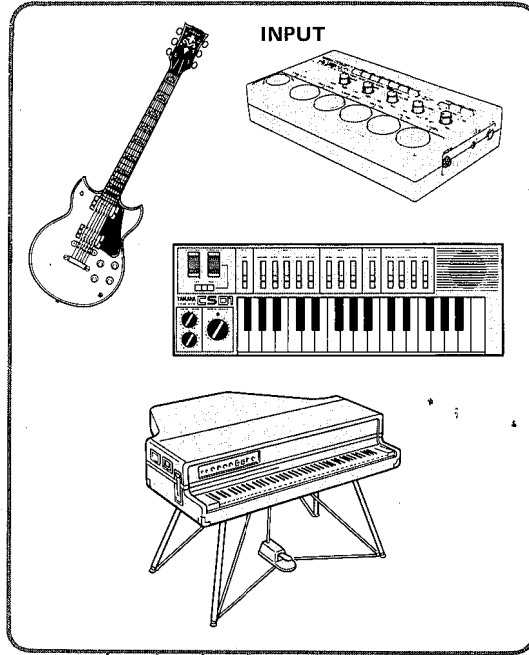
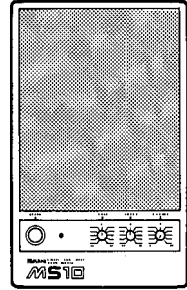

MT44 REAR PANEL

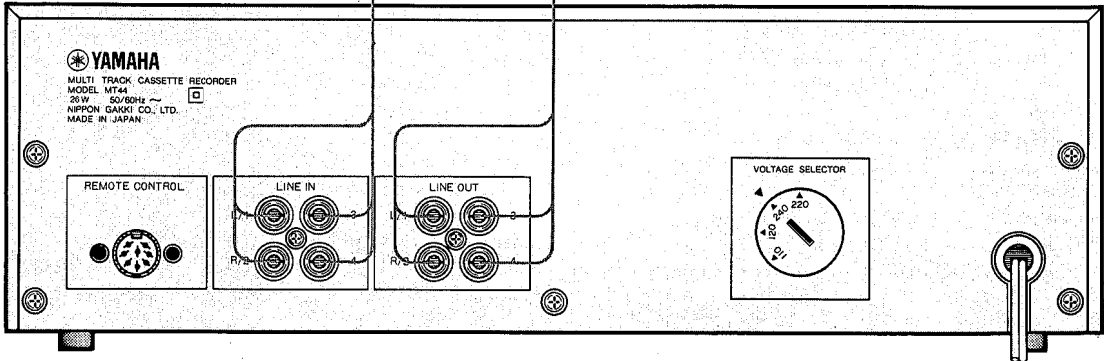

Caution:
Feedback may occur if the MM30 inputs are set to TAPE while the MT44 channels are set to the REC mode.

BLOCK DIAGRAM/SPECIFICATIONS

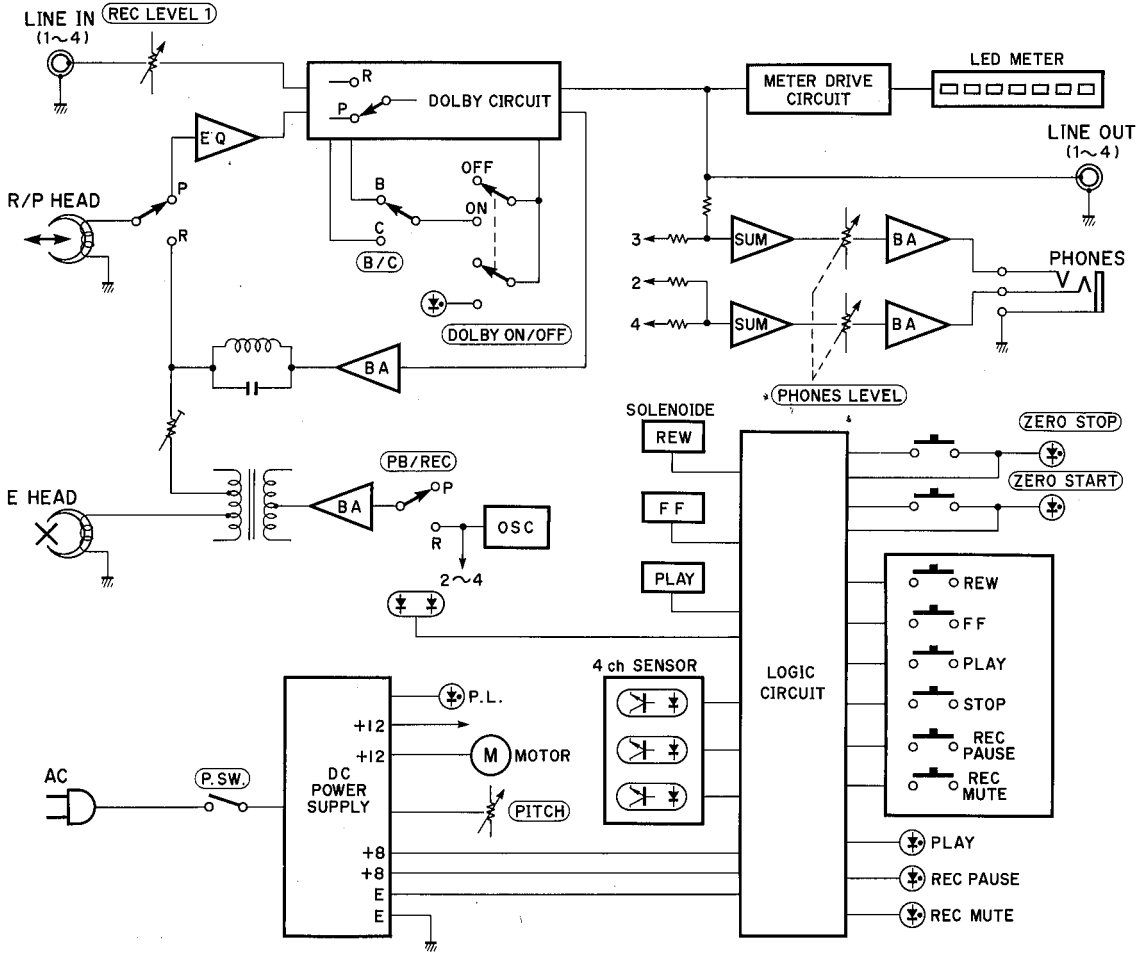

■ SPECIFICATIONS

TRACK CONFIGURATION . . . 4 track, 2 channel/4 track,
TRANSPORT CONTROL . . . 4 channel

feather touch, full logic control

MECHANICAL SECTION

Tape CrO₂ tape only (EQ:70μs)
 Tape Speed 4.75 cm/sec.
 Pitch Control ± 10%
 Wow & Flutter 0.06% (WRMS)
 Fast Wind Time 90 sec. (C-60)
 Motor DC servo motor

HEAD SECTION

Recording/Playback head . . Hard permalloy
 Erase head Ferrite

AMPLIFIER SECTION

Recording Method AC bias (bias freq. 85kHz)
 Erase Method AC erasure
 REC/PB Frequency Response 40Hz ~ 14,000Hz
 ± 3 dB
 Input Sensitivity/Impedance -10 dB (245mV)/
 50k-ohms
 Output Level/Impedance -10 dB (245mV)/
 2.5k-ohms

Total Signal to Noise Ratio (EIAJ)

Dolby off 55 dB
 Dolby B on 63 dB
 Dolby C on 67 dB

Total Distortion Less than 1.0% (315Hz,
 EIAJ)

Channel Separation Better than 50 dB (1kHz)
 Erasing Ratio Better than 70 dB (1kHz)

GENERAL

Power Supply

U.S. & Canadian models . . . 120V, 60Hz.
 General model 110/130/220/240V,
 50/60Hz

Power Consumption

U.S. & Canadian models . . . 26W
 General model 26W

Dimensions (WxHxD) 340x107x315 mm
 (13-3/8"x4-1/4"x12-3/8")

Weight 5.5 kg (12 lbs. 2 oz)

Accessories Connection Cord x 4
 Sensor Seals

Options RC10 (Remote Control)
 PB44 (Patch Bay Unit)

Specifications subject to change without notice.

MAINTENANCE

■ Maintenance

After the deck has been used for a long period of time, the heads, pinch roller and capstan will become dirty, leading to noise and uneven rotation so that recording is no longer possible. We therefore recommend that cleaning and demagnetization be carried out on a regular basis.

To carry out cleaning, remove the cassette holder cover and wipe the inside parts with a cotton swab (available commercially). Impregnated with alcohol or head cleaning solution. It should be remembered that keeping the heads clean is of great importance in obtaining good recordings.

For demagnetization, carefully follow the instructions given in the head demagnetizer manual.

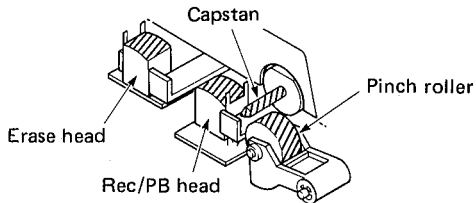

All parts must be kept clean.

● Removing the holder cover

Press the ejector button so that the cassette holder opens. Grasping the holder cover, pull it upwards and the cover will come off. To fit the cover back into place, follow the reverse procedure.

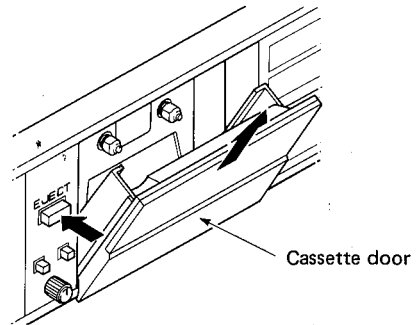

SERVICE

The MT44 are supported by Yamaha's worldwide network of factory trained and qualified dealer service personnel. In the event of a problem, contact your nearest Yamaha dealer.

SINCE 1887  **YAMAHA**
NIPPON GAKKI CO., LTD. HAMAMATSU, JAPAN